



ADDRESS  
RESIDENCES  
THE BAY

---

FLOOR PLANS

EMAAR



# ADDRESS RESIDENCES THE BAY

## 1 BEDROOM TYPE A 9

LEVEL 01 | UNIT 01

SUITE AREA	785.98 SQ.FT.	73.02 SQ.M.
BALCONY AREA	131.43 SQ.FT.	12.21 SQ.M.
TOTAL AREA	917.41 SQ.FT.	85.23 SQ.M.

KEY PLAN LEVEL  
01

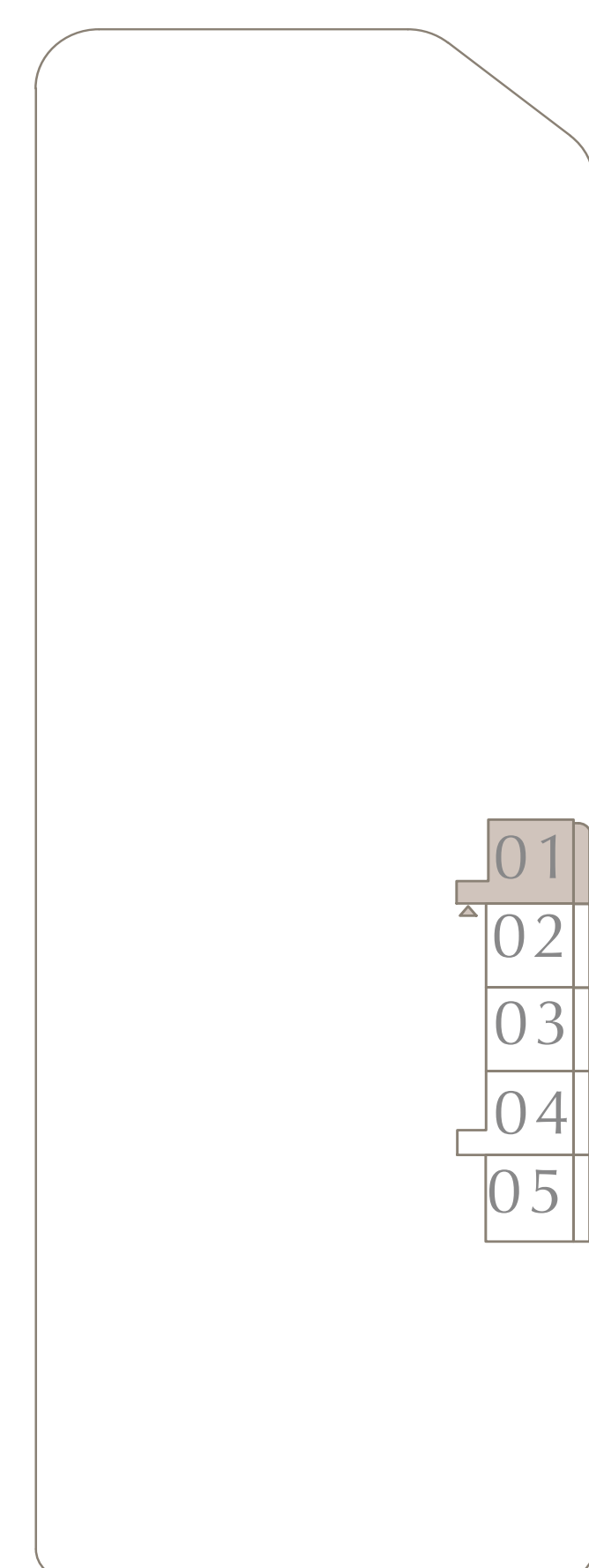
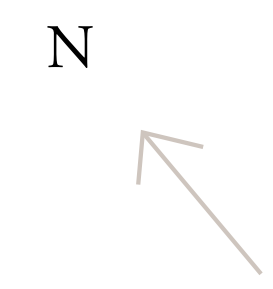

KEY SECTION

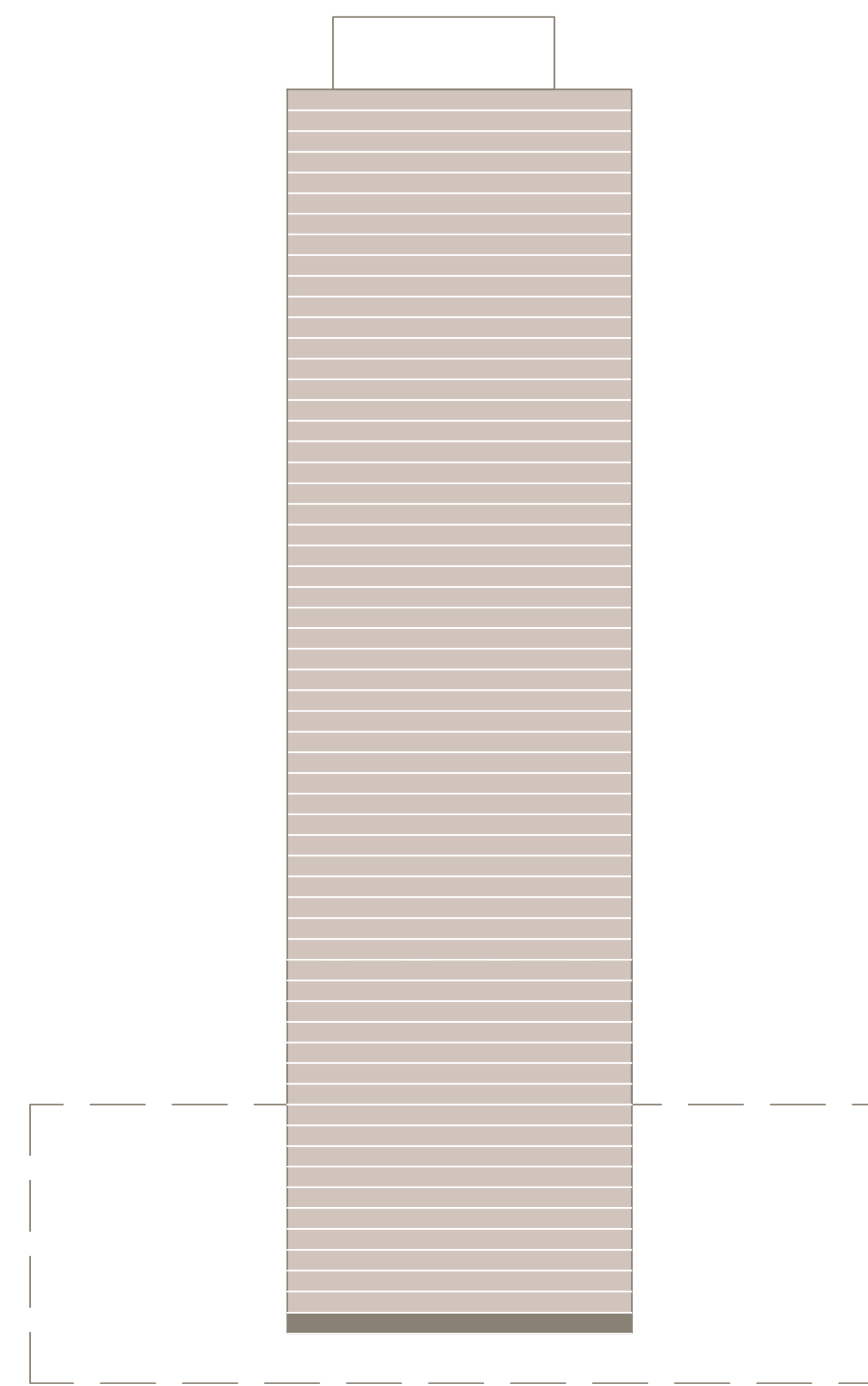

Disclaimer : All dimensions are in imperial and metric, and measured from finish to finish excluding construction tolerances. 2. All materials, dimensions, and drawings are approximate only. 3. Information is subject to change without notice, at developer's absolute discretion. 4. Actual area may vary from the stated area. 5. Drawings not to scale. 6. All images used are for illustrative purposes only and do not represent the actual size, features, specifications, fittings, and furnishings. 7. The developer reserves the right to make revisions / alterations, at its absolute discretion, without any liability whatsoever.



# ADDRESS RESIDENCES THE BAY

## 1 BEDROOM TYPE A 8

LEVELS 01-02 | UNIT 02

SUITE AREA	698.36 SQ.FT.	64.88 SQ.M.
BALCONY AREA	141.98 SQ.FT.	13.19 SQ.M.
TOTAL AREA	840.34 SQ.FT.	78.07 SQ.M.

KEY PLAN LEVEL

01-02

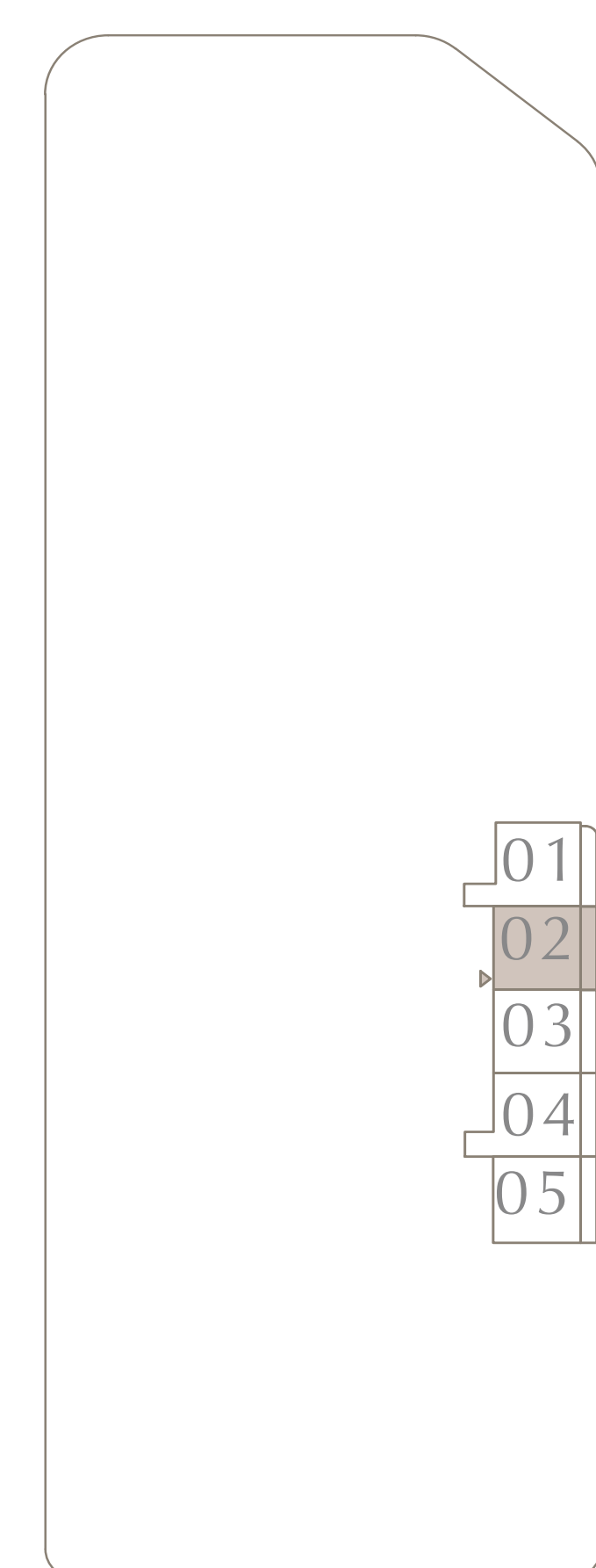
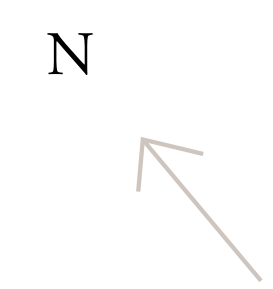

KEY SECTION

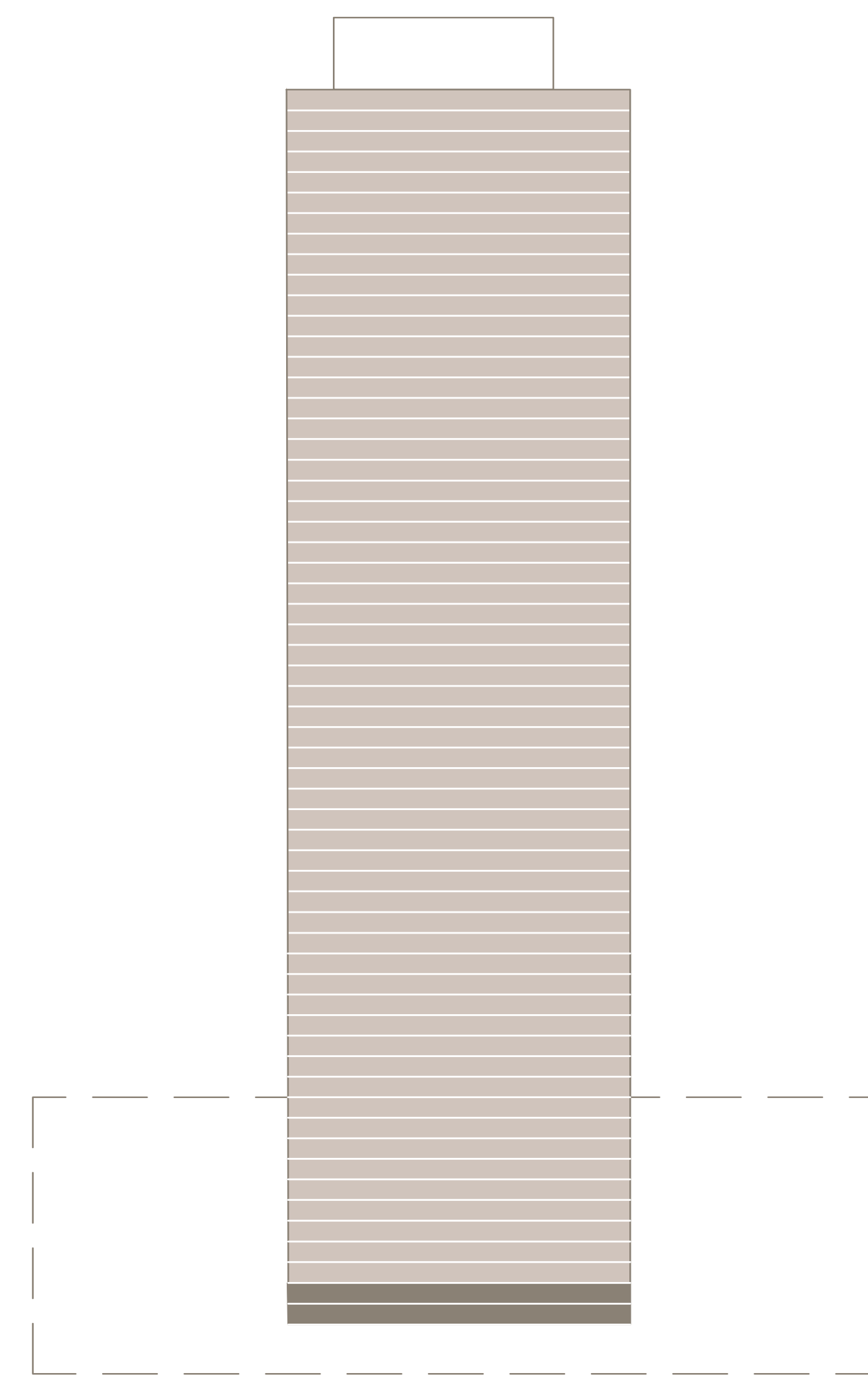

Disclaimer : All dimensions are in imperial and metric, and measured from finish to finish excluding construction tolerances. 2. All materials, dimensions, and drawings are approximate only. 3. Information is subject to change without notice, at developer's absolute discretion. 4. Actual area may vary from the stated area. 5. Drawings not to scale. 6. All images used are for illustrative purposes only and do not represent the actual size, features, specifications, fittings, and furnishings. 7. The developer reserves the right to make revisions / alterations, at its absolute discretion, without any liability whatsoever.



# ADDRESS RESIDENCES THE BAY

## 1 BEDROOM TYPE A 8

LEVELS 01-02 | UNIT 03

SUITE AREA	702.99 SQ.FT.	65.31 SQ.M.
BALCONY AREA	141.98 SQ.FT.	13.19 SQ.M.
TOTAL AREA	844.97 SQ.FT.	78.50 SQ.M.

KEY PLAN LEVEL

01-02

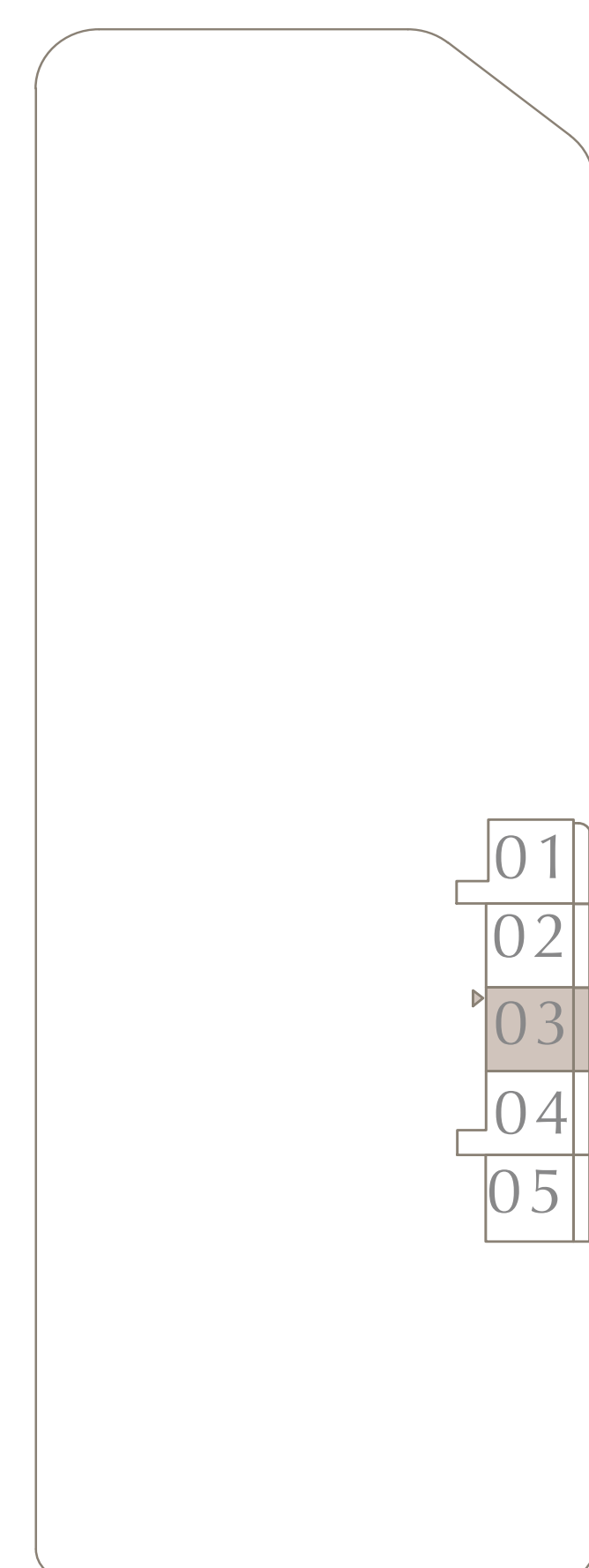
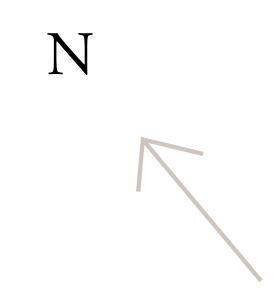

KEY SECTION

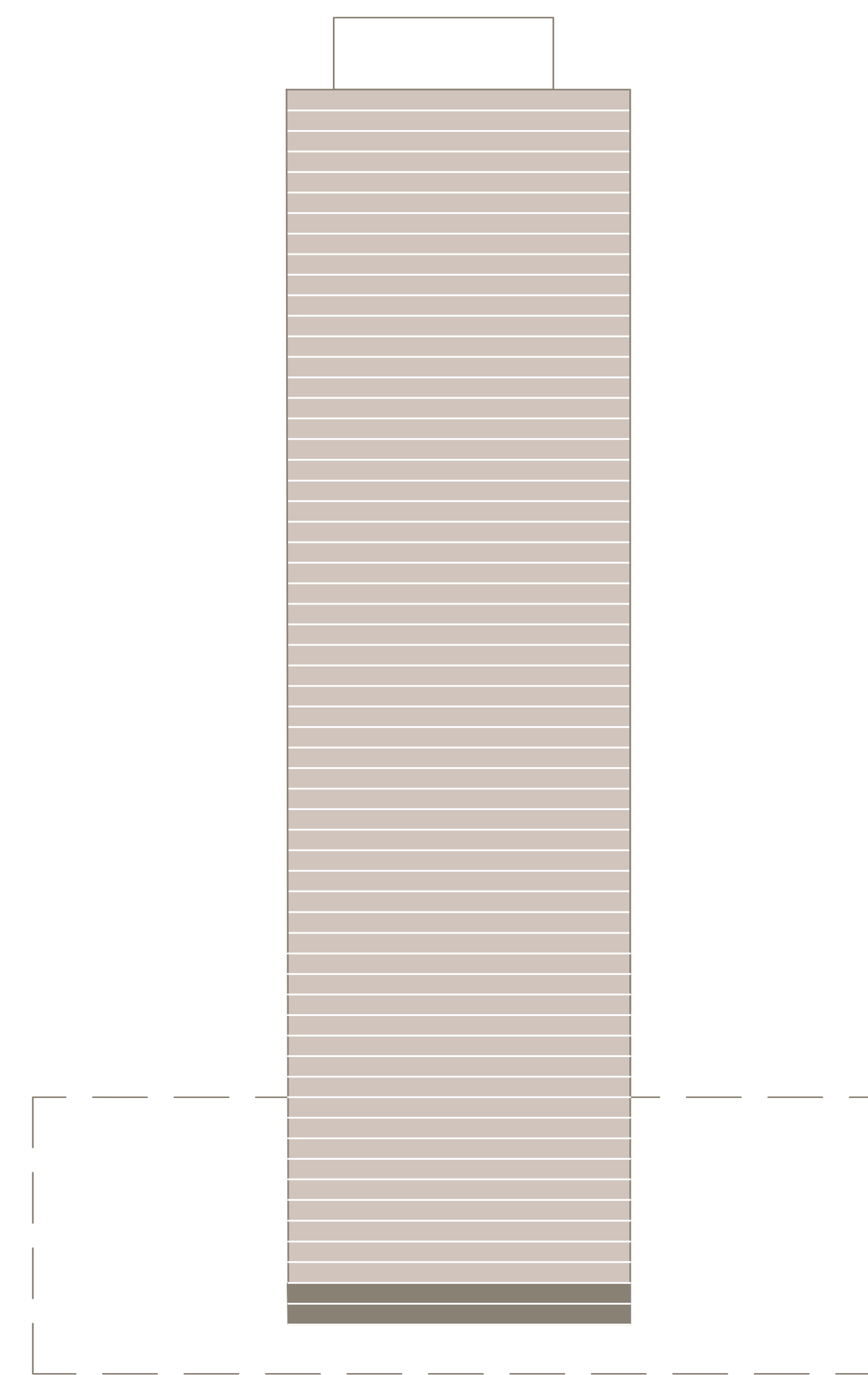

Disclaimer : All dimensions are in imperial and metric, and measured from finish to finish excluding construction tolerances. 2. All materials, dimensions, and drawings are approximate only. 3. Information is subject to change without notice, at developer's absolute discretion. 4. Actual area may vary from the stated area. 5. Drawings not to scale. 6. All images used are for illustrative purposes only and do not represent the actual size, features, specifications, fittings, and furnishings. 7. The developer reserves the right to make revisions / alterations, at its absolute discretion, without any liability whatsoever.



# ADDRESS RESIDENCES THE BAY

## 1 BEDROOM TYPE A 10

LEVELS 01-02 | UNIT 04

SUITE AREA	766.28 SQ.FT.	71.19 SQ.M.
BALCONY AREA	141.98 SQ.FT.	13.19 SQ.M.
TOTAL AREA	908.26 SQ.FT.	84.38 SQ.M.

KEY PLAN LEVEL  
01-02

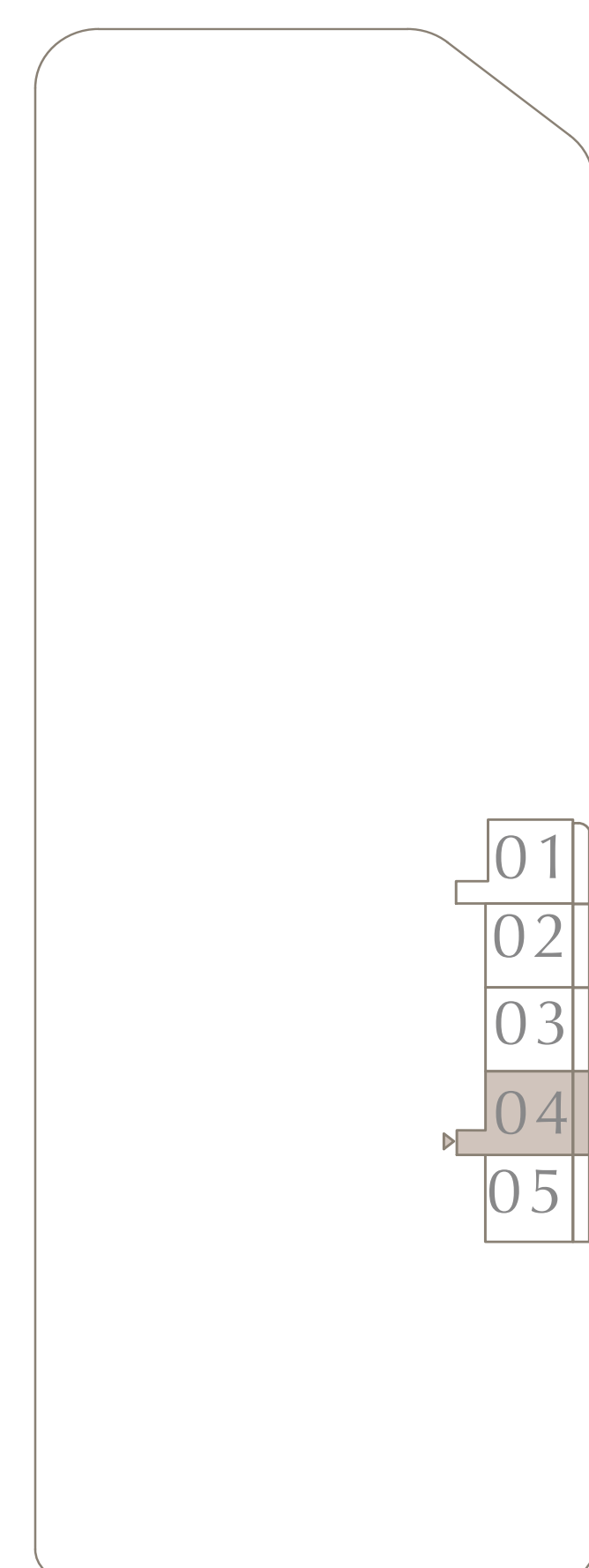
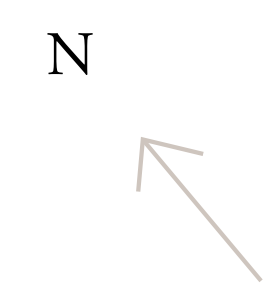

KEY SECTION

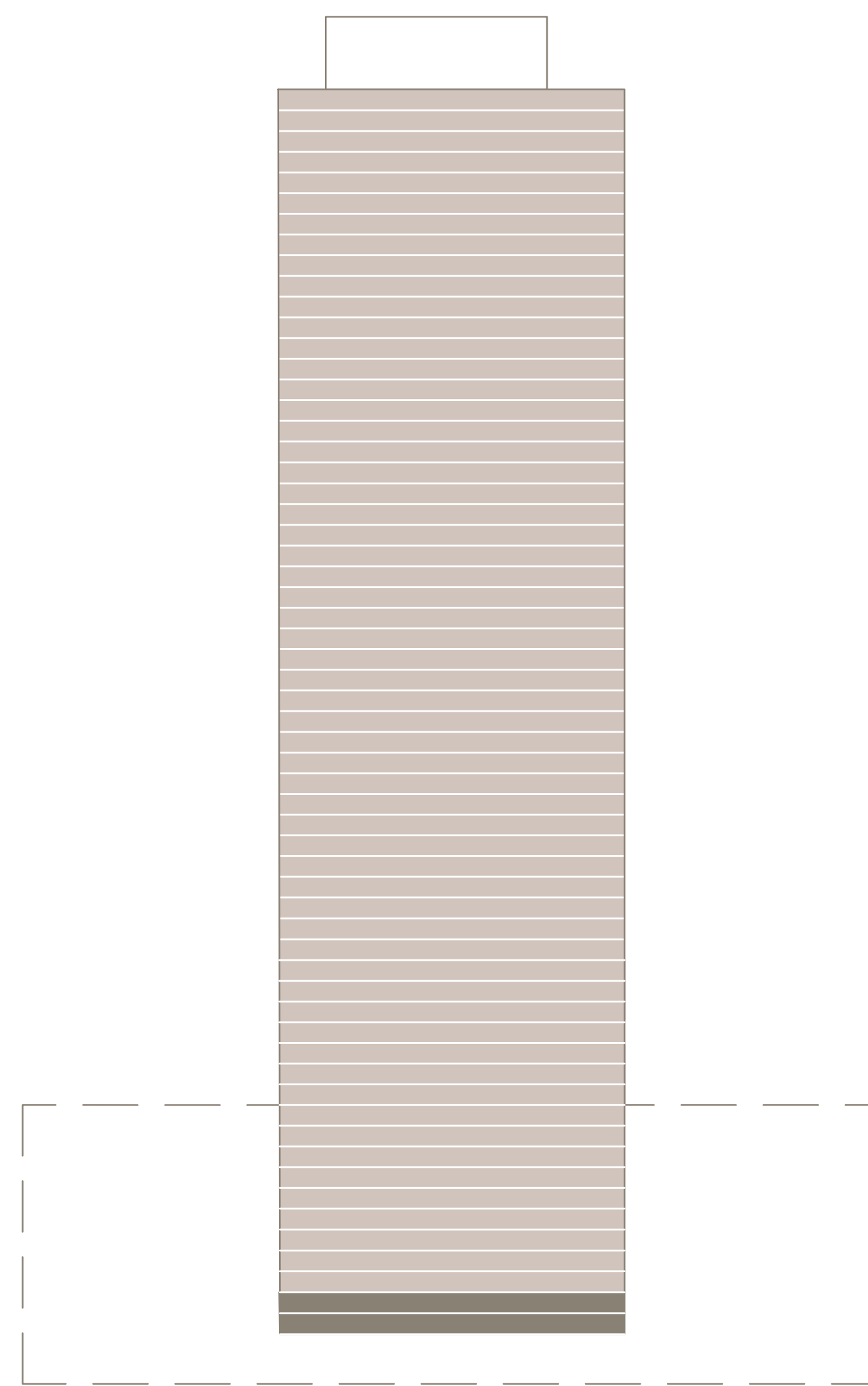

Disclaimer : All dimensions are in imperial and metric, and measured from finish to finish excluding construction tolerances. 2. All materials, dimensions, and drawings are approximate only. 3. Information is subject to change without notice, at developer's absolute discretion. 4. Actual area may vary from the stated area. 5. Drawings not to scale. 6. All images used are for illustrative purposes only and do not represent the actual size, features, specifications, fittings, and furnishings. 7. The developer reserves the right to make revisions / alterations, at its absolute discretion, without any liability whatsoever.



# ADDRESS RESIDENCES THE BAY

## 1 BEDROOM TYPE A 8

LEVELS 01-02 |

UNIT 05

SUITE AREA	698.58 SQ.FT.	64.90 SQ.M.
BALCONY AREA	141.98 SQ.FT.	13.19 SQ.M.
TOTAL AREA	840.56 SQ.FT.	78.09 SQ.M.

KEY PLAN LEVEL

01-02

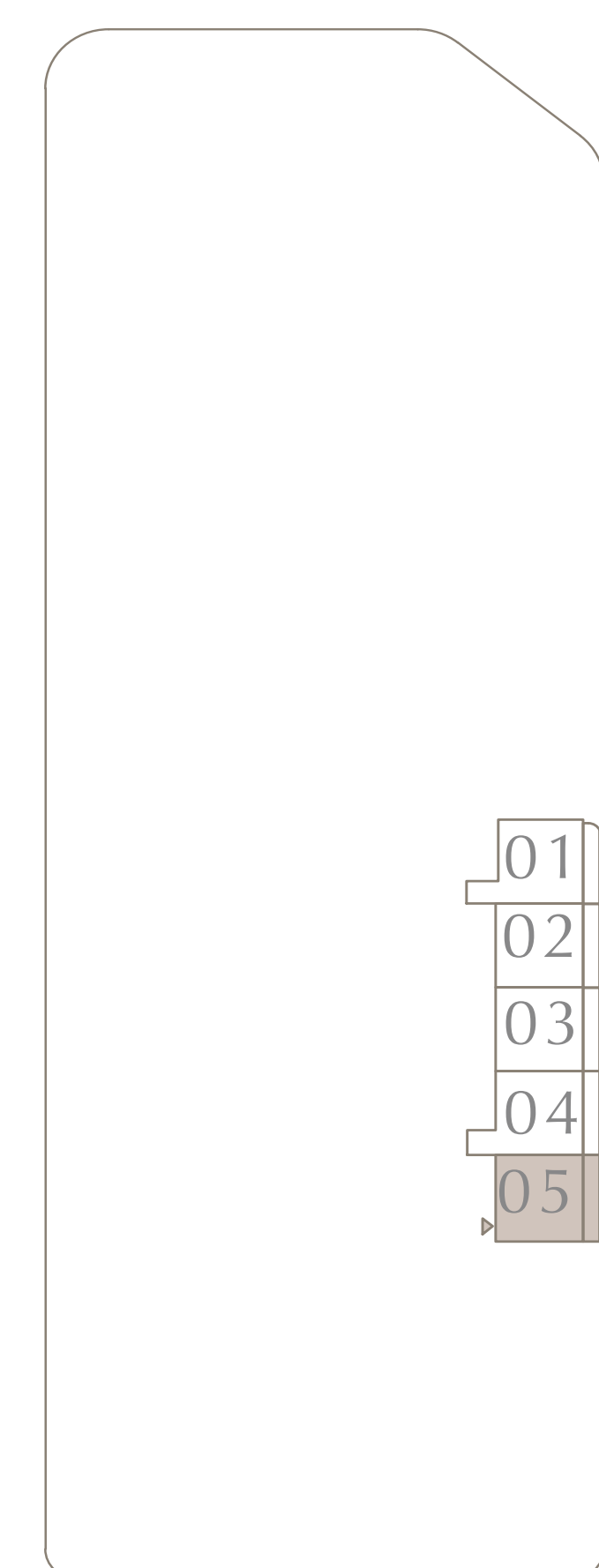
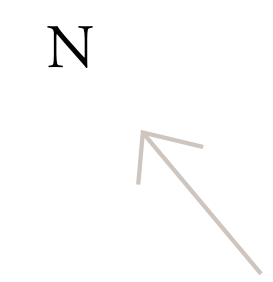

KEY SECTION

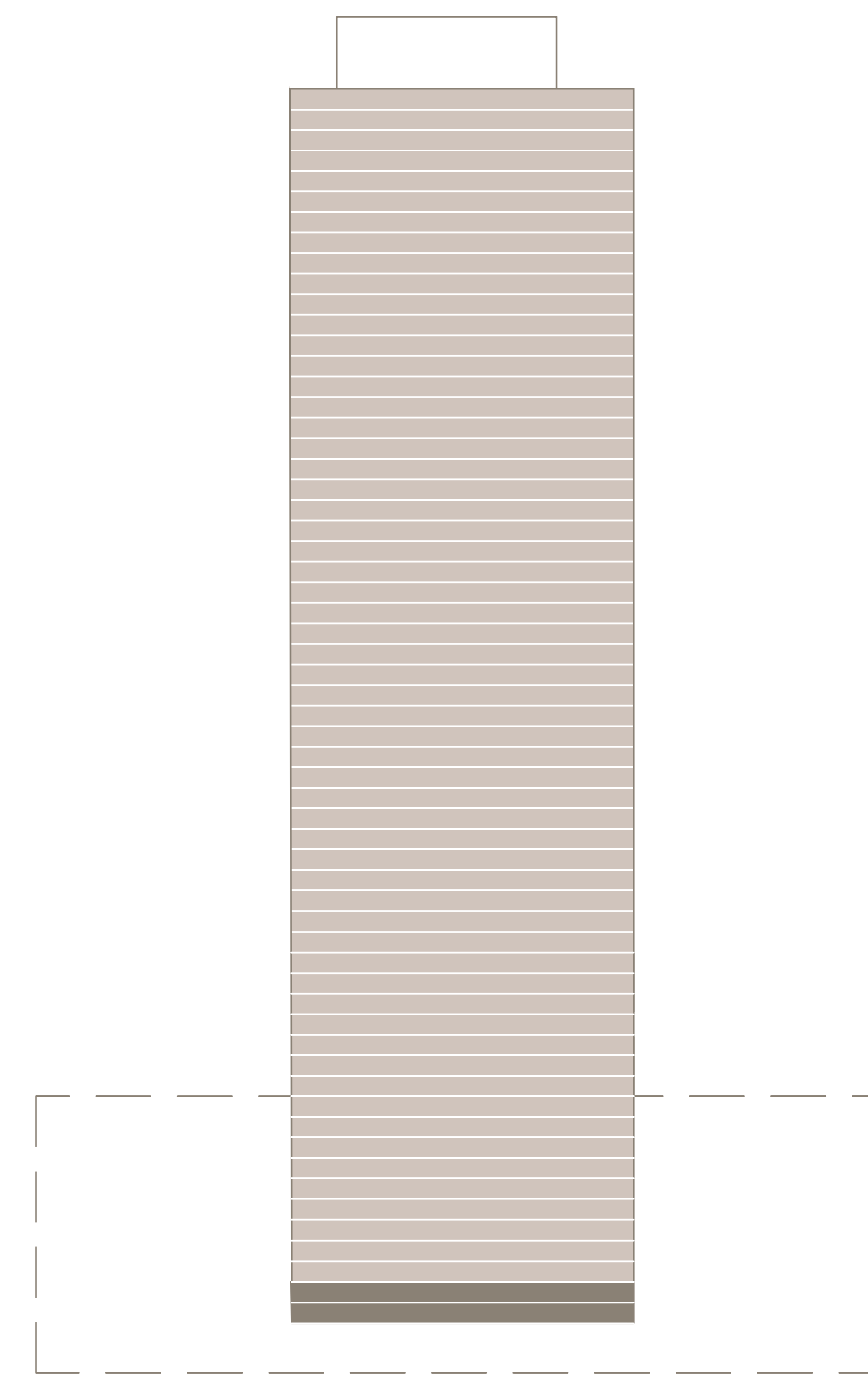

Disclaimer : All dimensions are in imperial and metric, and measured from finish to finish excluding construction tolerances. 2. All materials, dimensions, and drawings are approximate only. 3. Information is subject to change without notice, at developer's absolute discretion. 4. Actual area may vary from the stated area. 5. Drawings not to scale. 6. All images used are for illustrative purposes only and do not represent the actual size, features, specifications, fittings, and furnishings. 7. The developer reserves the right to make revisions / alterations, at its absolute discretion, without any liability whatsoever.



# ADDRESS RESIDENCES THE BAY

## 1 BEDROOM TYPE A 9

LEVEL 02 | UNIT 01

SUITE AREA	786.20 SQ.FT.	73.04 SQ.M.
BALCONY AREA	131.43 SQ.FT.	12.21 SQ.M.
TOTAL AREA	917.63 SQ.FT.	85.25 SQ.M.

KEY PLAN LEVEL  
02

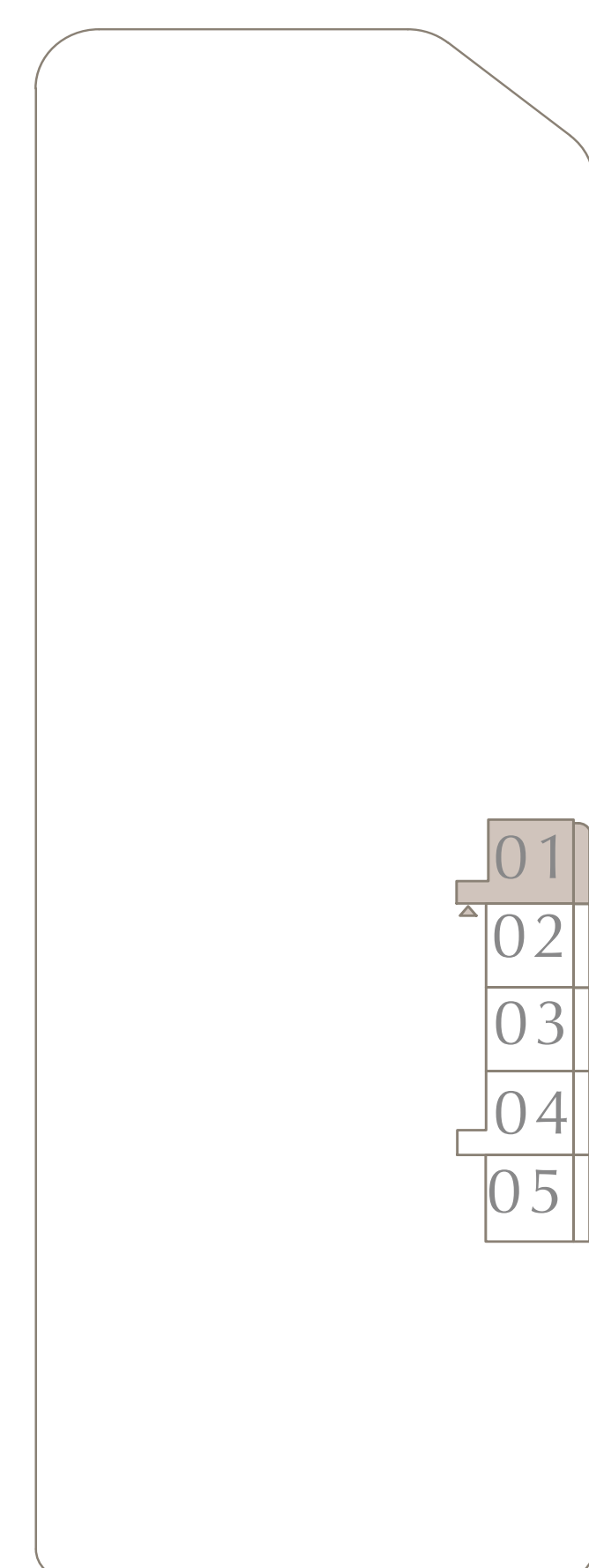
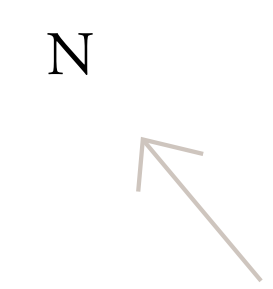

01  
02  
03  
04  
05

KEY SECTION

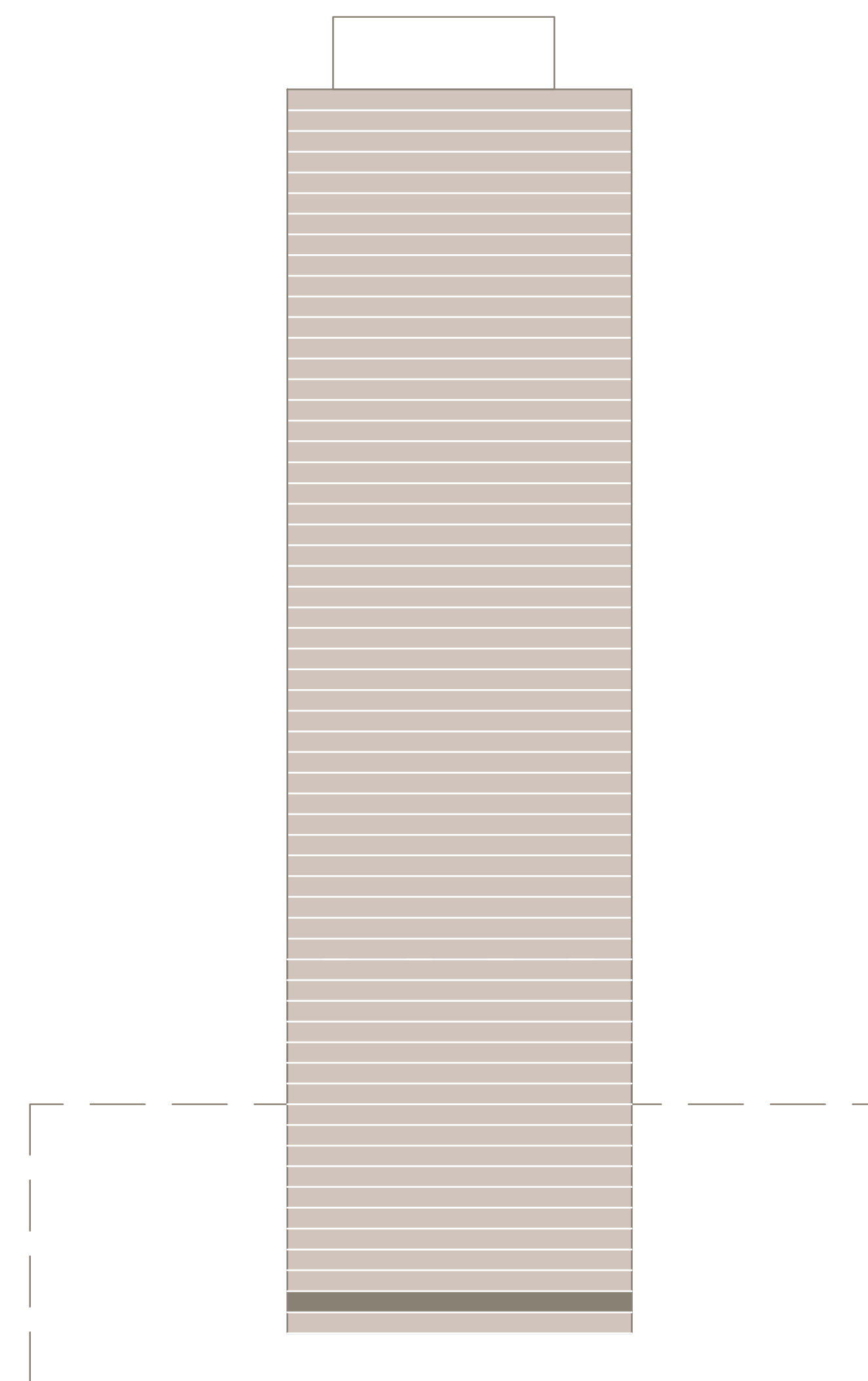

Disclaimer : All dimensions are in imperial and metric, and measured from finish to finish excluding construction tolerances. 2. All materials, dimensions, and drawings are approximate only. 3. Information is subject to change without notice, at developer's absolute discretion. 4. Actual area may vary from the stated area. 5. Drawings not to scale. 6. All images used are for illustrative purposes only and do not represent the actual size, features, specifications, fittings, and furnishings. 7. The developer reserves the right to make revisions / alterations, at its absolute discretion, without any liability whatsoever.



# ADDRESS RESIDENCES THE BAY

## 1 BEDROOM TYPE A 9

LEVEL 03 | UNIT 01

SUITE AREA	786.20 SQ.FT.	73.04 SQ.M.
BALCONY AREA	131.43 SQ.FT.	12.21 SQ.M.
TOTAL AREA	917.63 SQ.FT.	85.25 SQ.M.

KEY PLAN LEVEL  
03

KEY SECTION

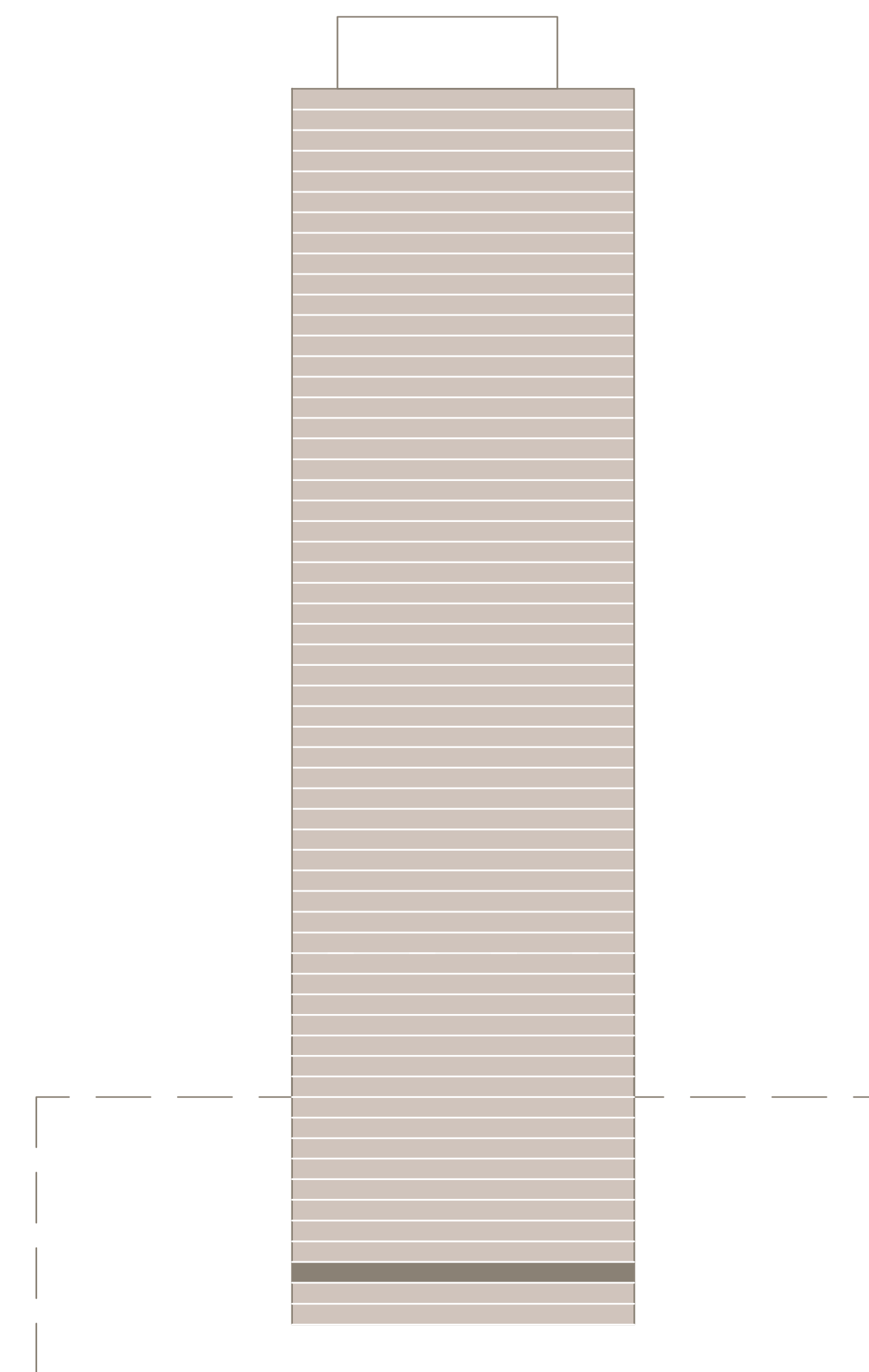
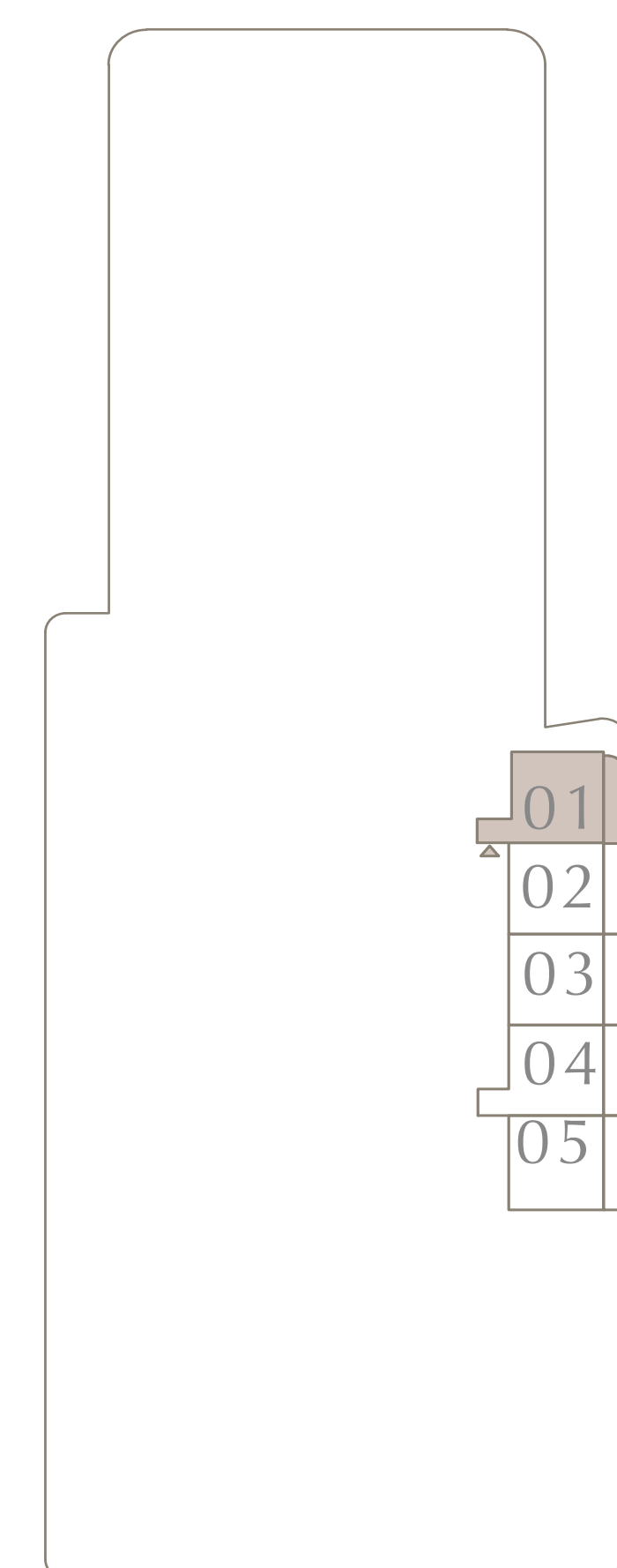
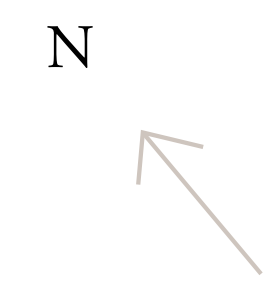

Disclaimer : All dimensions are in imperial and metric, and measured from finish to finish excluding construction tolerances. 2. All materials, dimensions, and drawings are approximate only. 3. Information is subject to change without notice, at developer's absolute discretion. 4. Actual area may vary from the stated area. 5. Drawings not to scale. 6. All images used are for illustrative purposes only and do not represent the actual size, features, specifications, fittings, and furnishings. 7. The developer reserves the right to make revisions / alterations, at its absolute discretion, without any liability whatsoever.





# ADDRESS RESIDENCES THE BAY

## 1 BEDROOM TYPE A 8

LEVEL 03 | UNIT 02

SUITE AREA	698.36 SQ.FT.	64.88 SQ.M.
BALCONY AREA	141.98 SQ.FT.	13.19 SQ.M.
TOTAL AREA	840.34 SQ.FT.	78.07 SQ.M.

KEY PLAN LEVEL

03

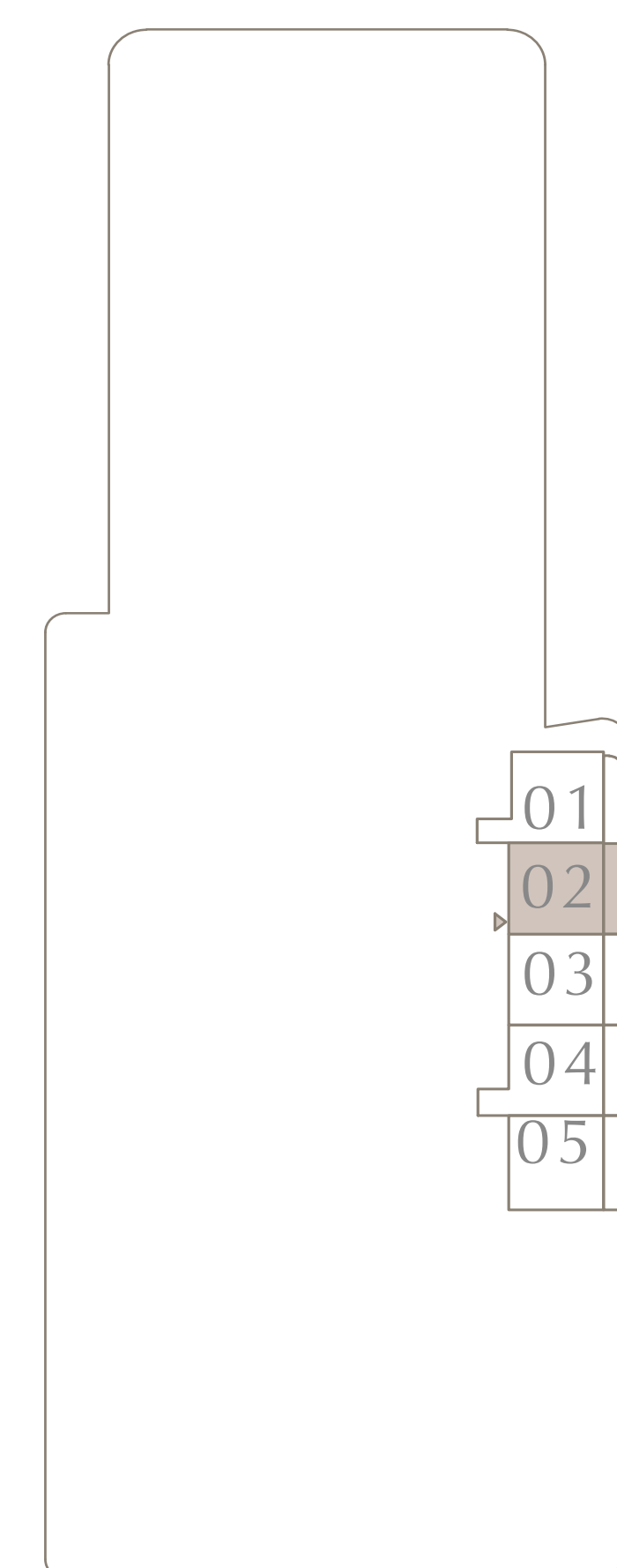
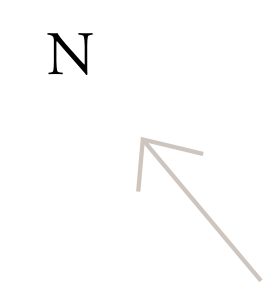

KEY SECTION

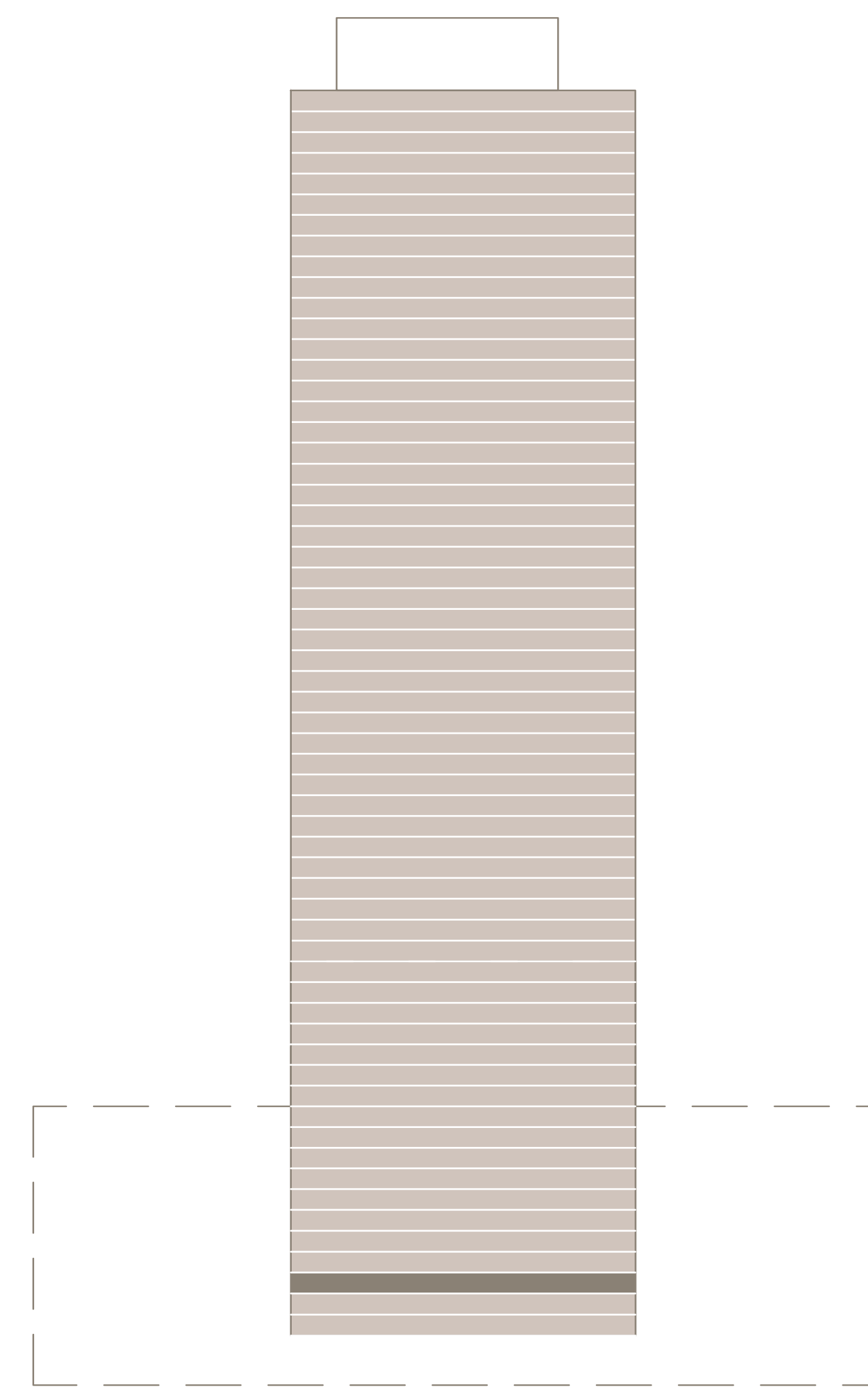

Disclaimer : All dimensions are in imperial and metric, and measured from finish to finish excluding construction tolerances. 2. All materials, dimensions, and drawings are approximate only. 3. Information is subject to change without notice, at developer's absolute discretion. 4. Actual area may vary from the stated area. 5. Drawings not to scale. 6. All images used are for illustrative purposes only and do not represent the actual size, features, specifications, fittings, and furnishings. 7. The developer reserves the right to make revisions / alterations, at its absolute discretion, without any liability whatsoever.



# ADDRESS RESIDENCES THE BAY

## 1 BEDROOM TYPE A 8

LEVEL 03 | UNIT 03

SUITE AREA	702.99 SQ.FT.	65.31 SQ.M.
BALCONY AREA	141.98 SQ.FT.	13.19 SQ.M.
TOTAL AREA	844.97 SQ.FT.	78.50 SQ.M.

KEY PLAN LEVEL

03

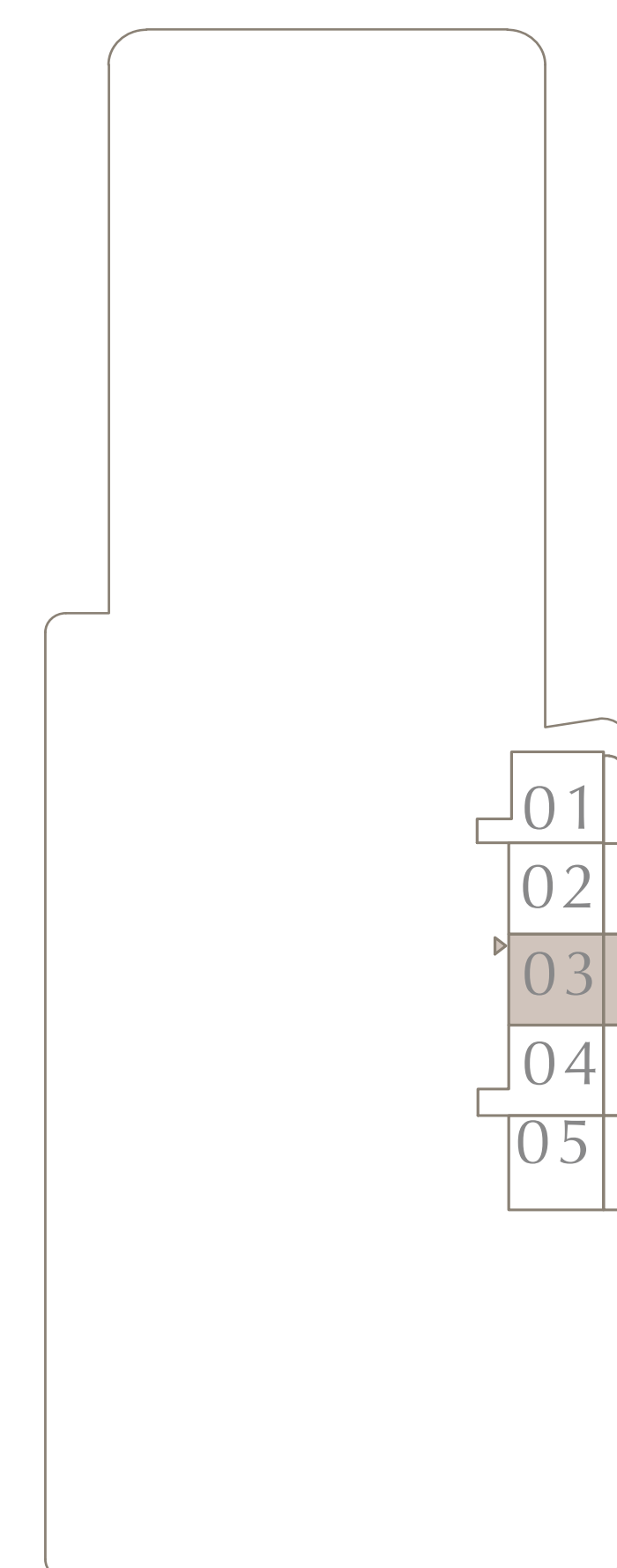
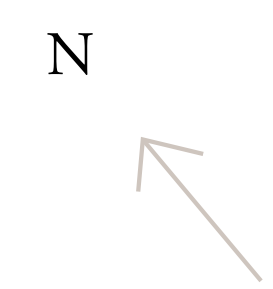

KEY SECTION

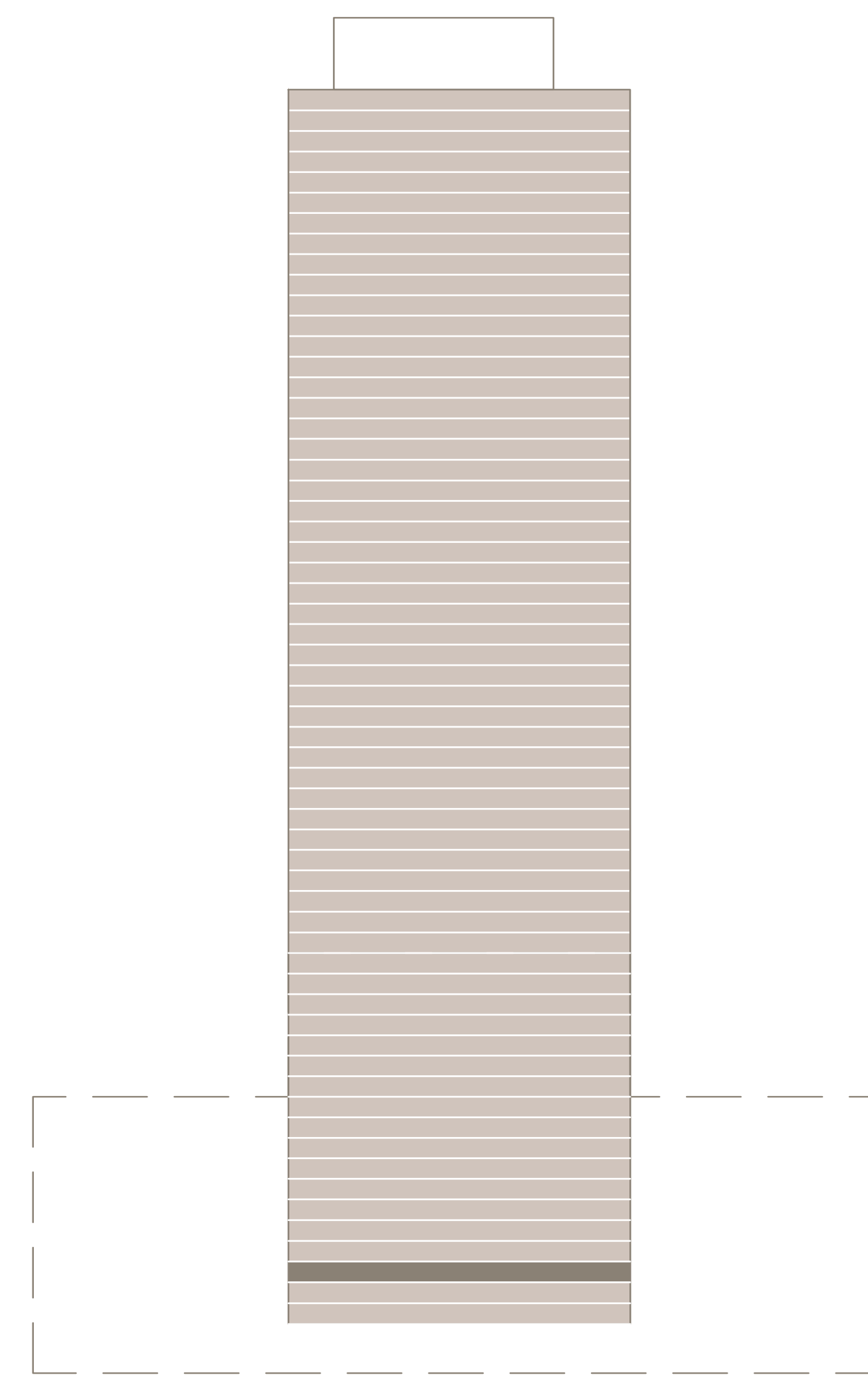

Disclaimer : All dimensions are in imperial and metric, and measured from finish to finish excluding construction tolerances. 2. All materials, dimensions, and drawings are approximate only. 3. Information is subject to change without notice, at developer's absolute discretion. 4. Actual area may vary from the stated area. 5. Drawings not to scale. 6. All images used are for illustrative purposes only and do not represent the actual size, features, specifications, fittings, and furnishings. 7. The developer reserves the right to make revisions / alterations, at its absolute discretion, without any liability whatsoever.



# ADDRESS RESIDENCES THE BAY

## 1 BEDROOM TYPE A 10

LEVEL 03 | UNIT 04

SUITE AREA	766.28 SQ.FT.	71.19 SQ.M.
BALCONY AREA	141.98 SQ.FT.	13.19 SQ.M.
TOTAL AREA	908.26 SQ.FT.	84.38 SQ.M.

KEY PLAN LEVEL  
03

KEY SECTION

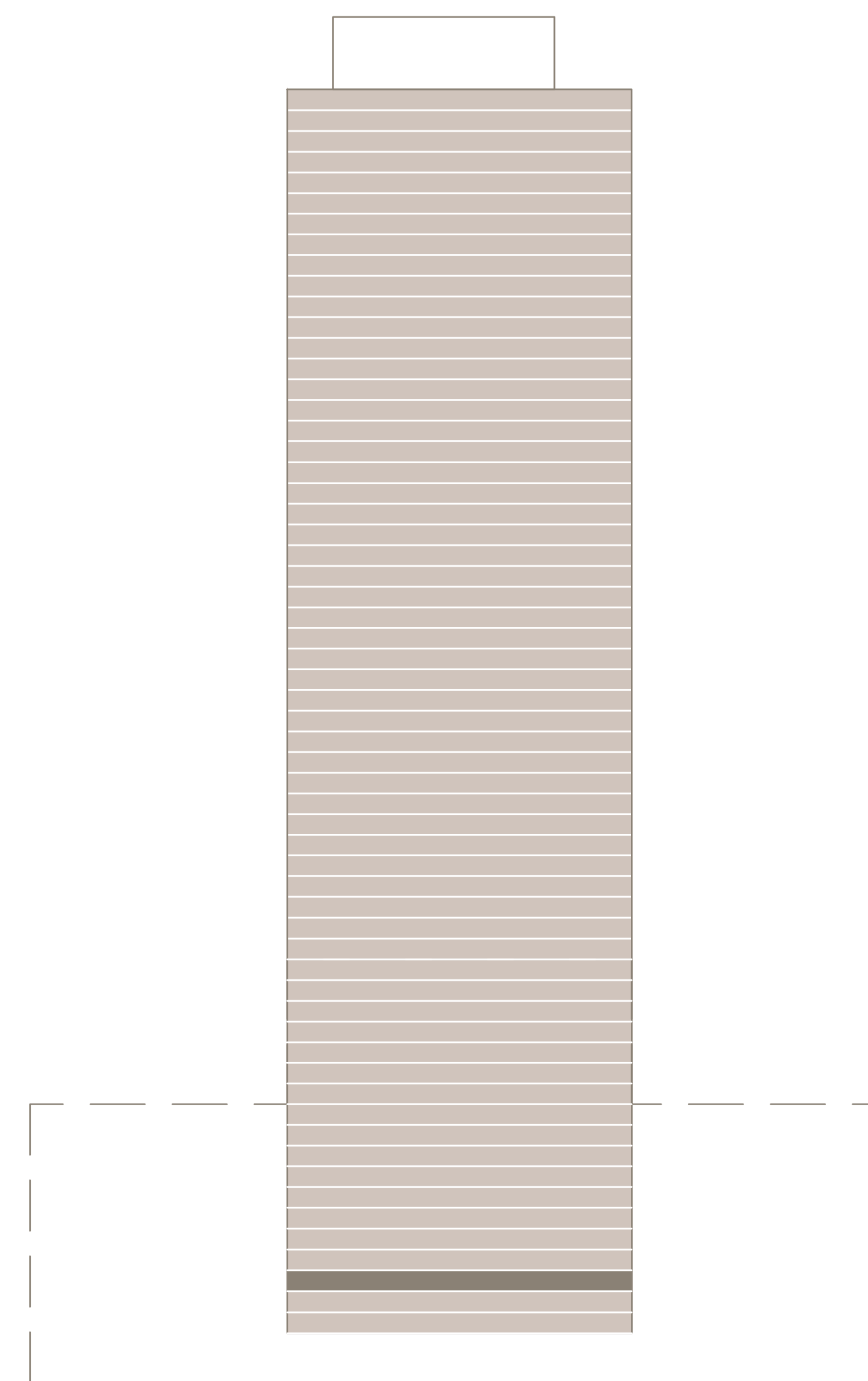
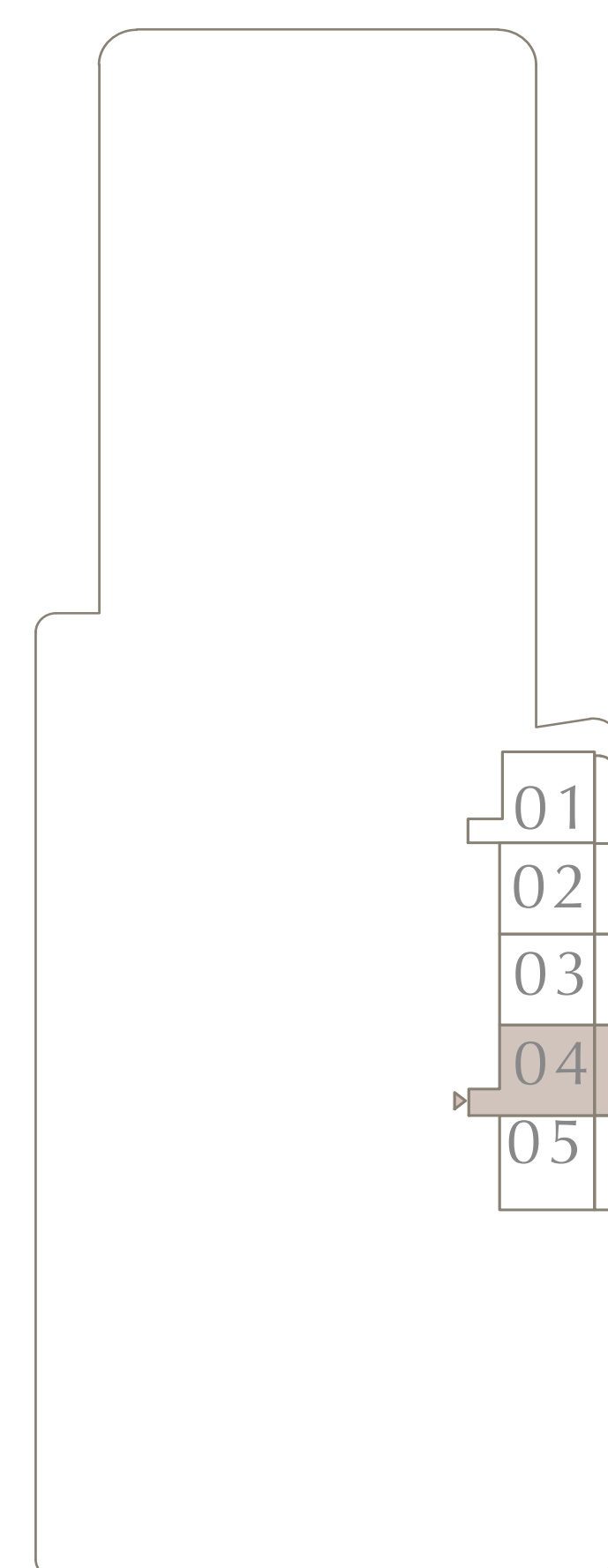
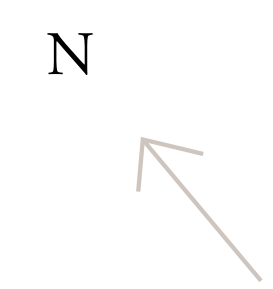

Disclaimer : All dimensions are in imperial and metric, and measured from finish to finish excluding construction tolerances. 2. All materials, dimensions, and drawings are approximate only. 3. Information is subject to change without notice, at developer's absolute discretion. 4. Actual area may vary from the stated area. 5. Drawings not to scale. 6. All images used are for illustrative purposes only and do not represent the actual size, features, specifications, fittings, and furnishings. 7. The developer reserves the right to make revisions / alterations, at its absolute discretion, without any liability whatsoever.



# ADDRESS RESIDENCES THE BAY

## 1 BEDROOM TYPE A 8

LEVEL 03 |

UNIT 05

SUITE AREA	698.58 SQ.FT.	64.90 SQ.M.
BALCONY AREA	141.98 SQ.FT.	13.19 SQ.M.
TOTAL AREA	840.56 SQ.FT.	78.09 SQ.M.

KEY PLAN LEVEL

03

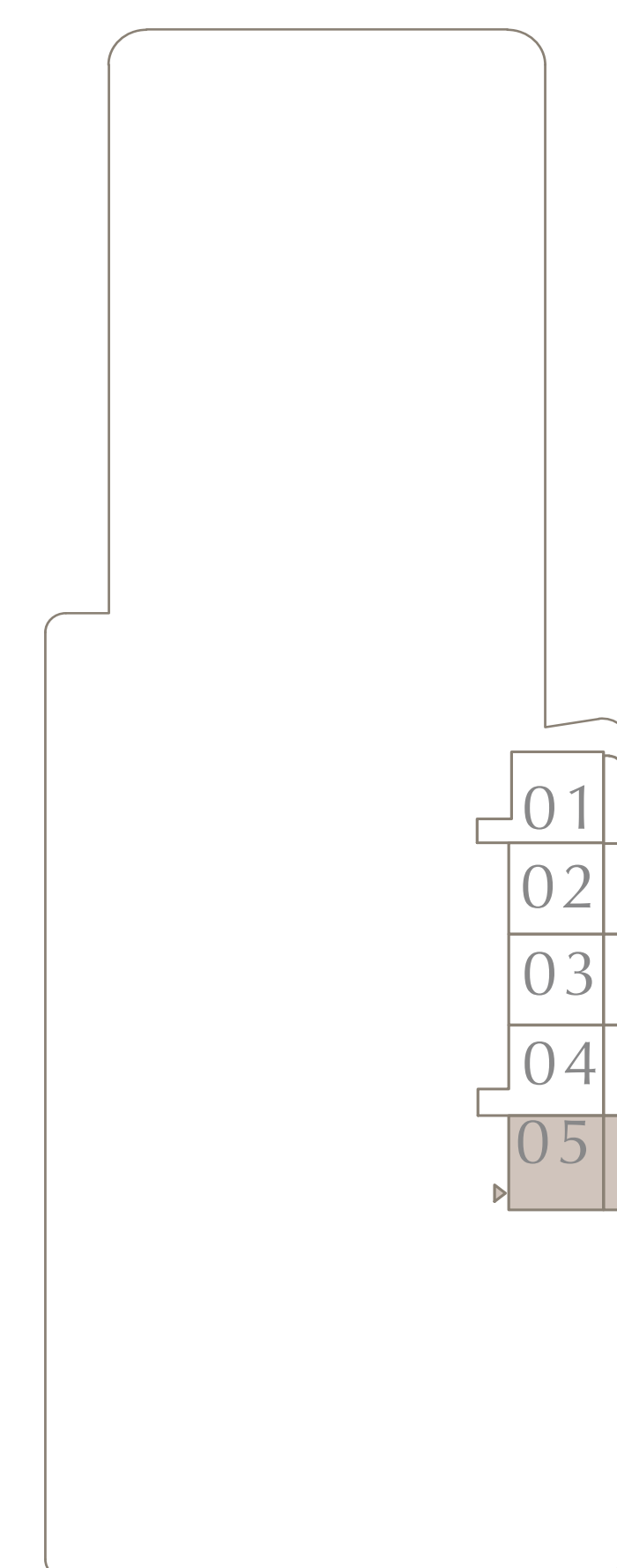
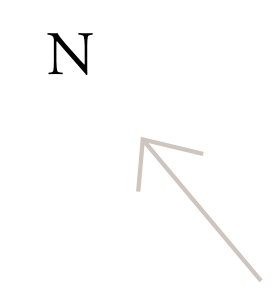

KEY SECTION

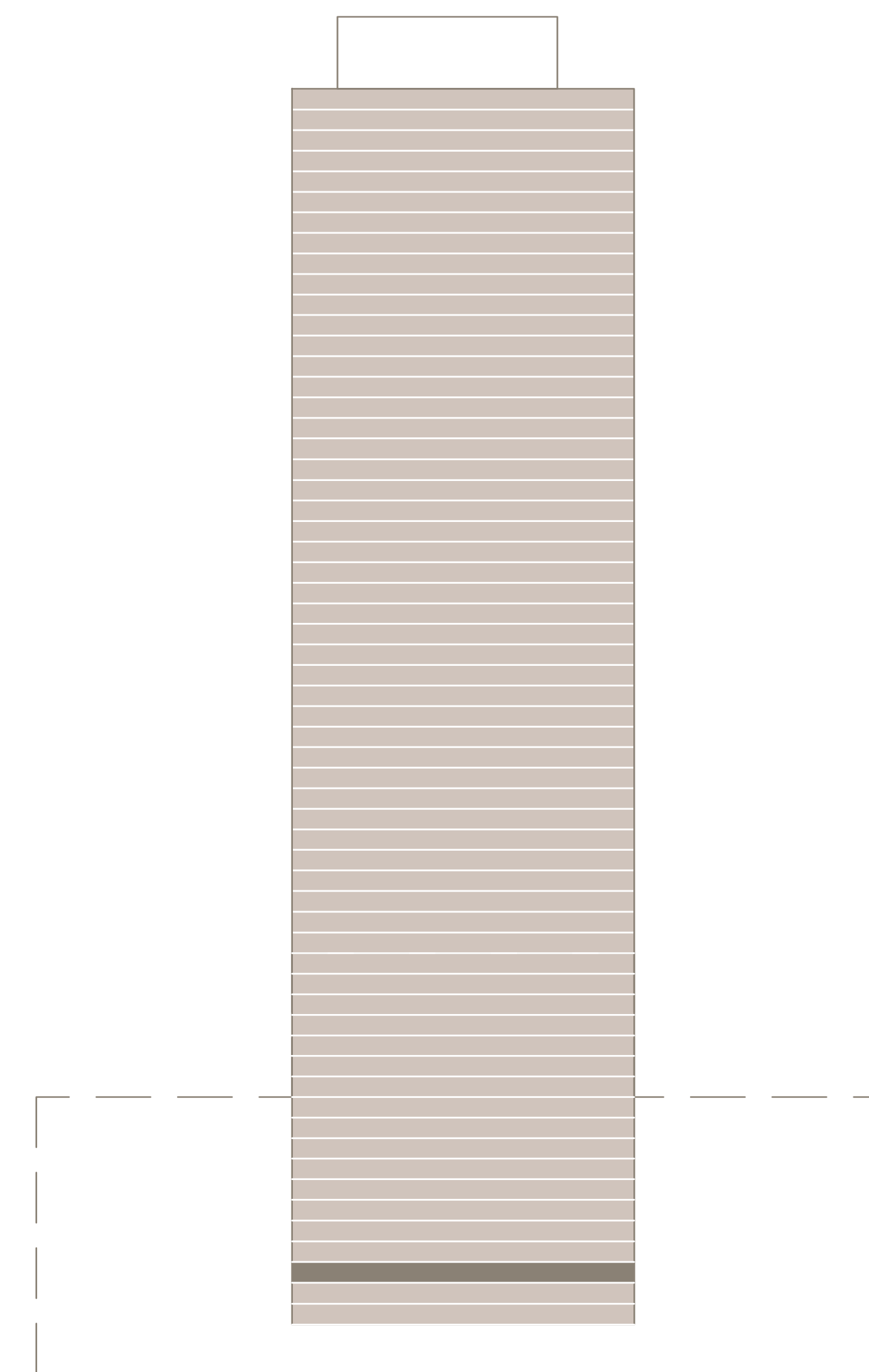

Disclaimer : All dimensions are in imperial and metric, and measured from finish to finish excluding construction tolerances. 2. All materials, dimensions, and drawings are approximate only. 3. Information is subject to change without notice, at developer's absolute discretion. 4. Actual area may vary from the stated area. 5. Drawings not to scale. 6. All images used are for illustrative purposes only and do not represent the actual size, features, specifications, fittings, and furnishings. 7. The developer reserves the right to make revisions / alterations, at its absolute discretion, without any liability whatsoever.



# ADDRESS RESIDENCES THE BAY

## 1 BEDROOM TYPE A 9

LEVEL 04 | UNIT 01

SUITE AREA	785.98 SQ.FT.	73.02 SQ.M.
BALCONY AREA	131.43 SQ.FT.	12.21 SQ.M.
TOTAL AREA	917.41 SQ.FT.	85.23 SQ.M.

KEY PLAN LEVEL  
04

KEY SECTION

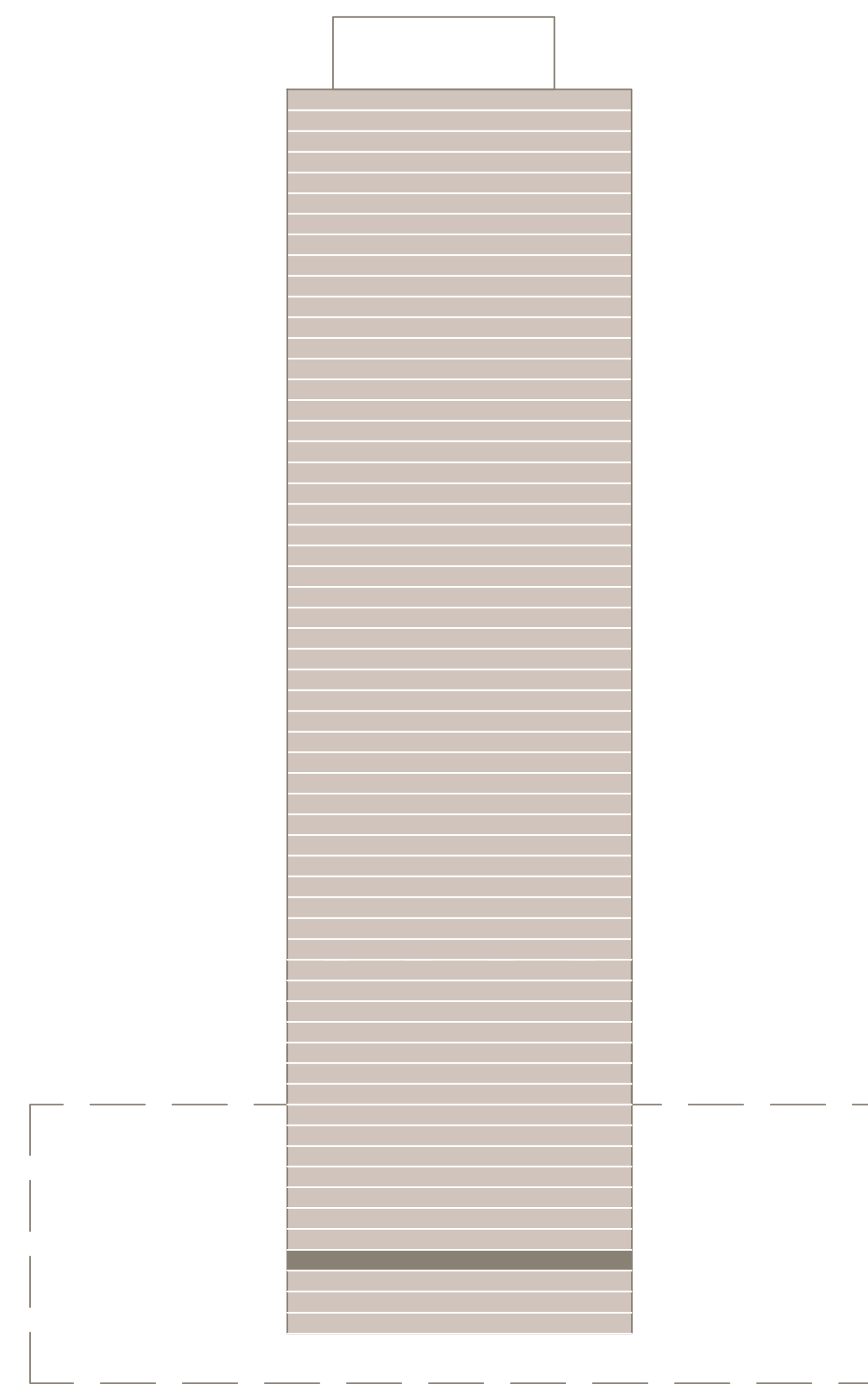
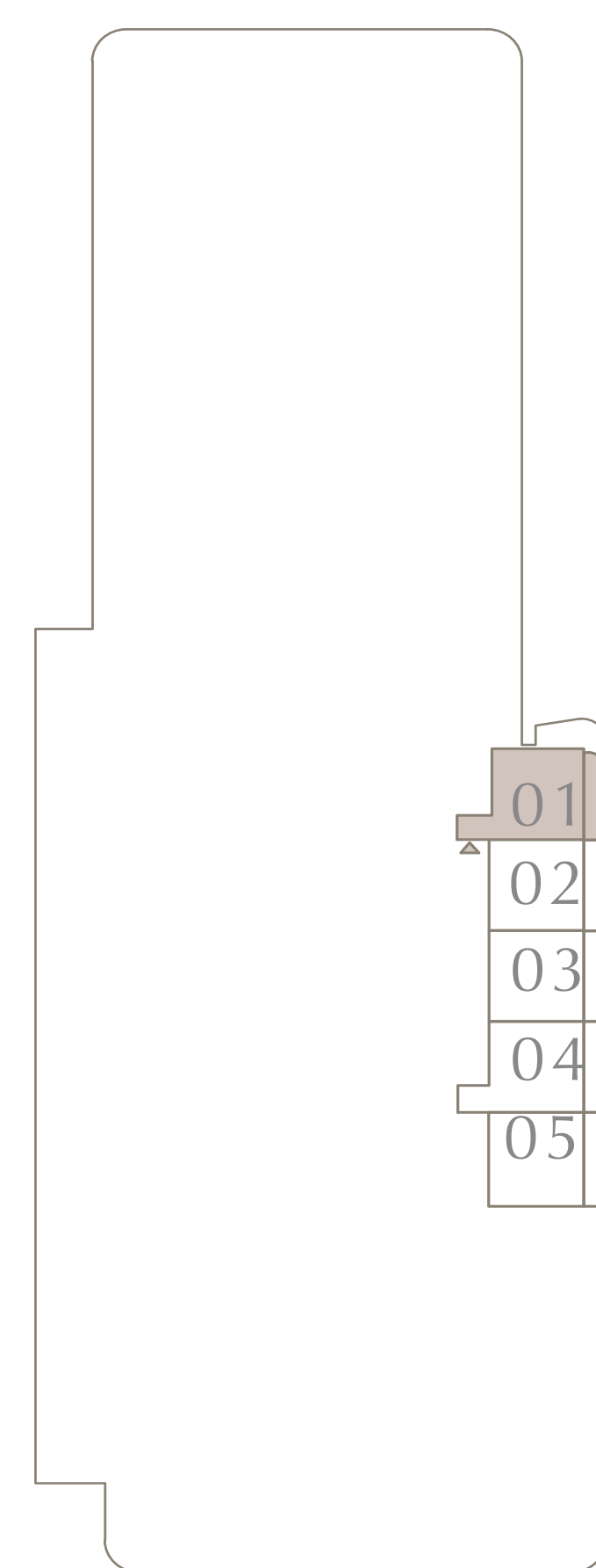
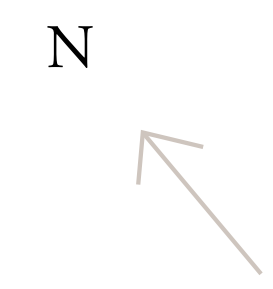

Disclaimer : All dimensions are in imperial and metric, and measured from finish to finish excluding construction tolerances. 2. All materials, dimensions, and drawings are approximate only. 3. Information is subject to change without notice, at developer's absolute discretion. 4. Actual area may vary from the stated area. 5. Drawings not to scale. 6. All images used are for illustrative purposes only and do not represent the actual size, features, specifications, fittings, and furnishings. 7. The developer reserves the right to make revisions / alterations, at its absolute discretion, without any liability whatsoever.



# ADDRESS RESIDENCES THE BAY

## 1 BEDROOM TYPE A 8

LEVELS 04-05 | UNIT 02

SUITE AREA	698.36 SQ.FT.	64.88 SQ.M.
BALCONY AREA	141.98 SQ.FT.	13.19 SQ.M.
TOTAL AREA	840.34 SQ.FT.	78.07 SQ.M.

KEY PLAN LEVEL

04-05

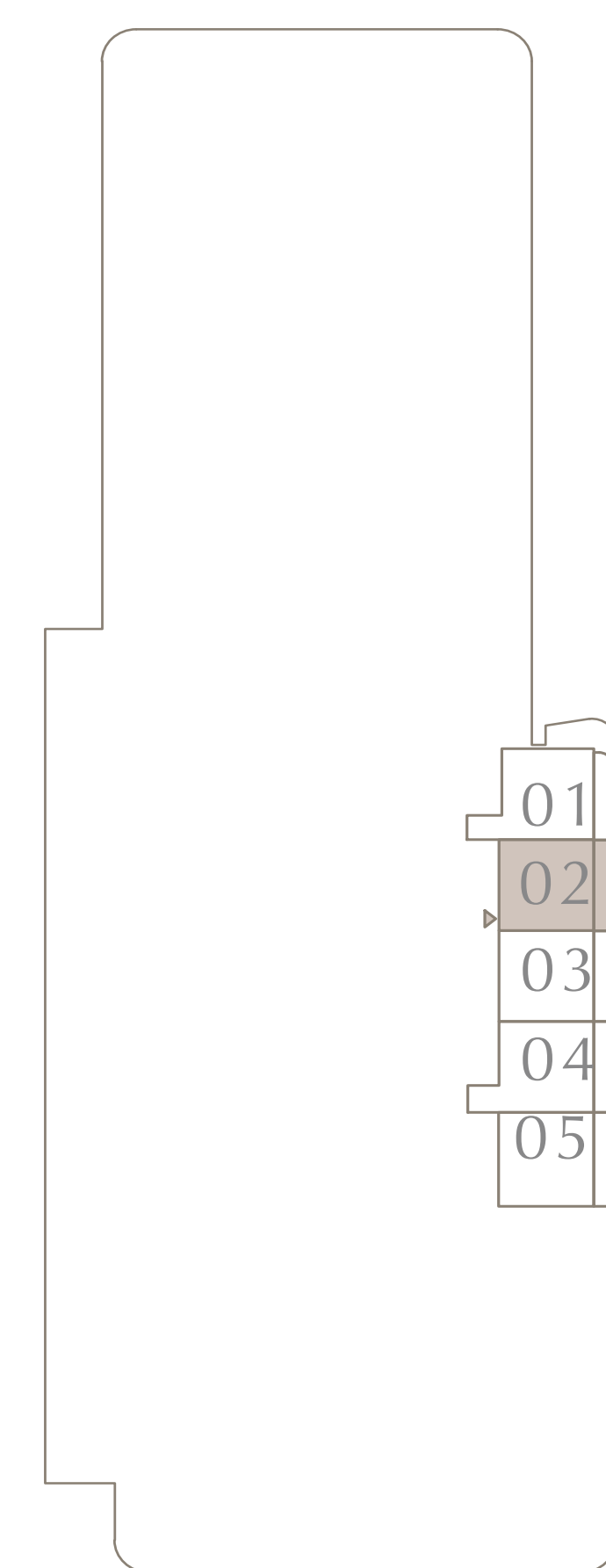
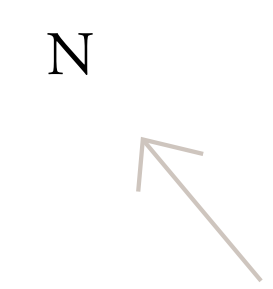

KEY SECTION

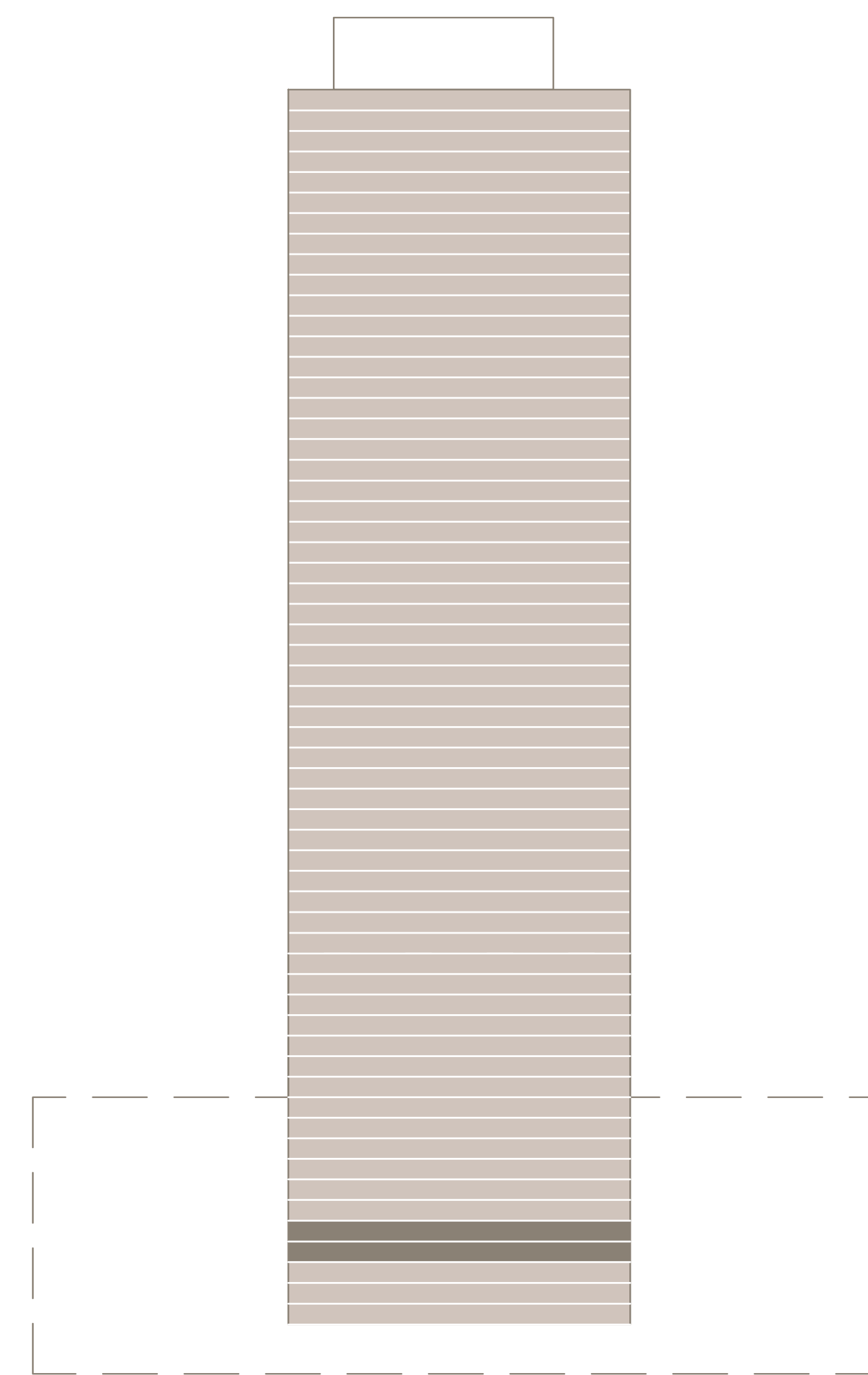

Disclaimer : All dimensions are in imperial and metric, and measured from finish to finish excluding construction tolerances. 2. All materials, dimensions, and drawings are approximate only. 3. Information is subject to change without notice, at developer's absolute discretion. 4. Actual area may vary from the stated area. 5. Drawings not to scale. 6. All images used are for illustrative purposes only and do not represent the actual size, features, specifications, fittings, and furnishings. 7. The developer reserves the right to make revisions / alterations, at its absolute discretion, without any liability whatsoever.



# ADDRESS RESIDENCES THE BAY

## 1 BEDROOM TYPE A 8

LEVELS 04-05 | UNIT 03

SUITE AREA	702.99 SQ.FT.	65.31 SQ.M.
BALCONY AREA	141.98 SQ.FT.	13.19 SQ.M.
TOTAL AREA	844.97 SQ.FT.	78.50 SQ.M.

KEY PLAN LEVEL

04-05

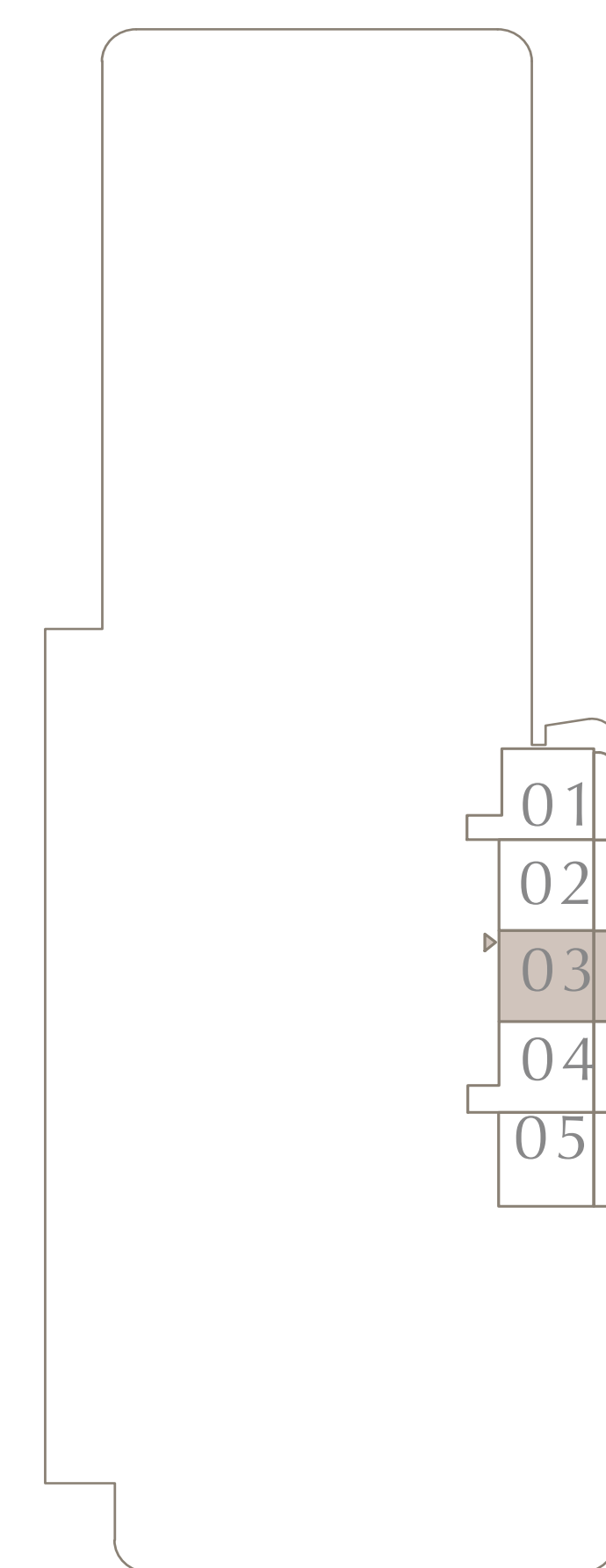
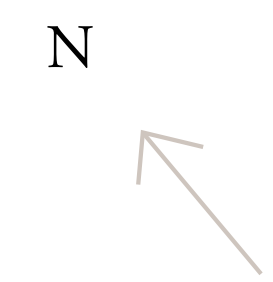

KEY SECTION

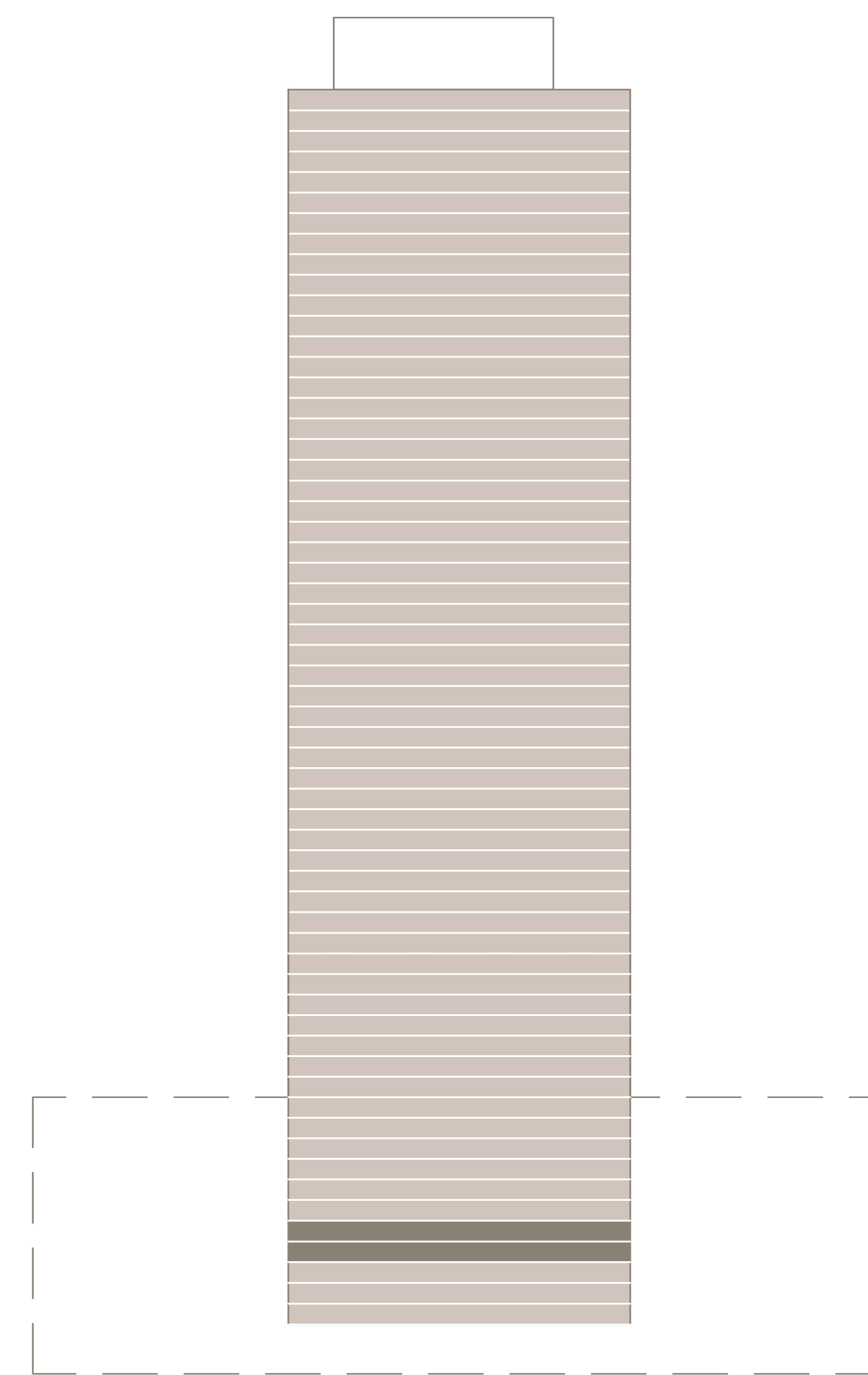

Disclaimer : All dimensions are in imperial and metric, and measured from finish to finish excluding construction tolerances. 2. All materials, dimensions, and drawings are approximate only. 3. Information is subject to change without notice, at developer's absolute discretion. 4. Actual area may vary from the stated area. 5. Drawings not to scale. 6. All images used are for illustrative purposes only and do not represent the actual size, features, specifications, fittings, and furnishings. 7. The developer reserves the right to make revisions / alterations, at its absolute discretion, without any liability whatsoever.



# ADDRESS RESIDENCES THE BAY

## 1 BEDROOM TYPE A 10

LEVEL 04 | UNIT 04

SUITE AREA	766.28 SQ.FT.	71.19 SQ.M.
BALCONY AREA	141.98 SQ.FT.	13.19 SQ.M.
TOTAL AREA	908.26 SQ.FT.	84.38 SQ.M.

KEY PLAN LEVEL  
04

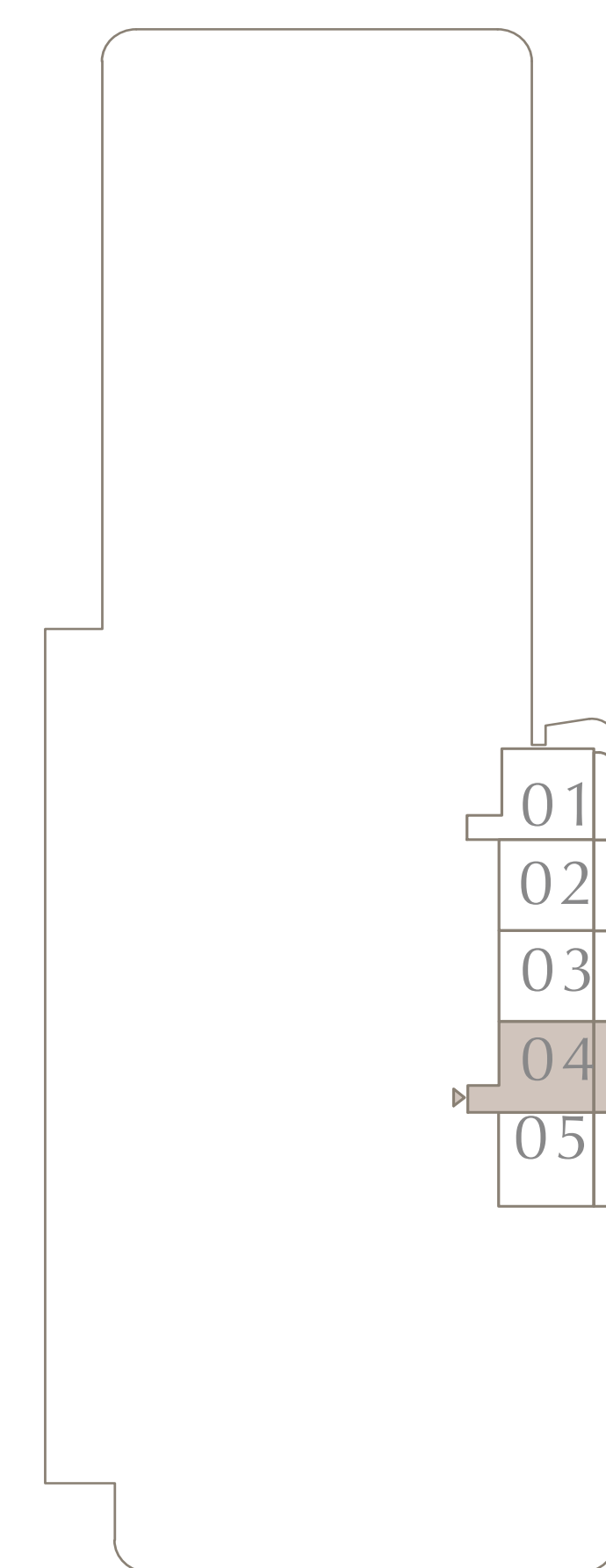
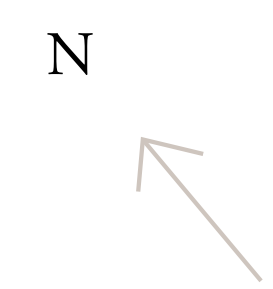

KEY SECTION

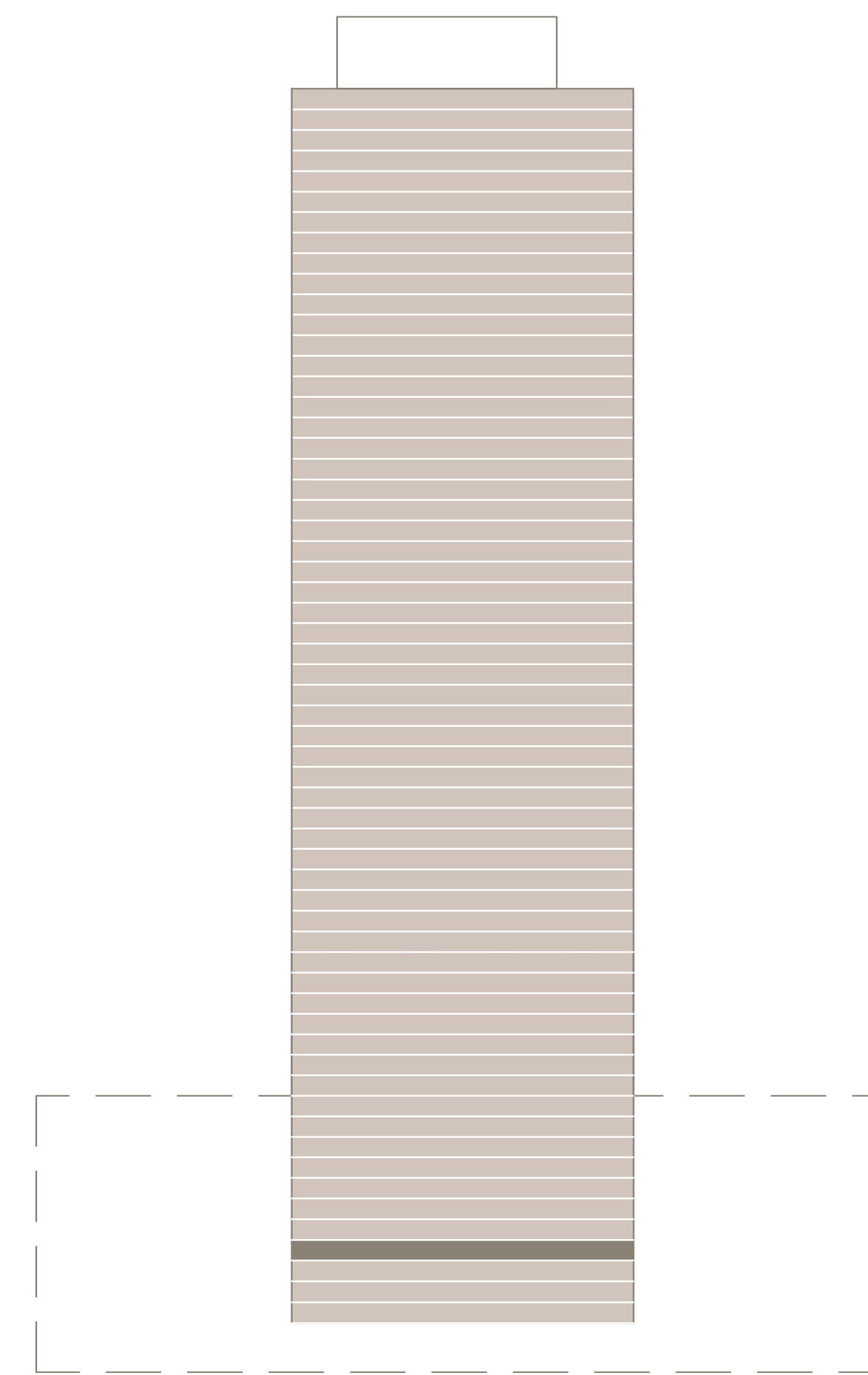

Disclaimer : All dimensions are in imperial and metric, and measured from finish to finish excluding construction tolerances. 2. All materials, dimensions, and drawings are approximate only. 3. Information is subject to change without notice, at developer's absolute discretion. 4. Actual area may vary from the stated area. 5. Drawings not to scale. 6. All images used are for illustrative purposes only and do not represent the actual size, features, specifications, fittings, and furnishings. 7. The developer reserves the right to make revisions / alterations, at its absolute discretion, without any liability whatsoever.





# ADDRESS RESIDENCES THE BAY

## 1 BEDROOM TYPE A 8

LEVELS 04-05 |

UNIT 05

SUITE AREA	698.58 SQ.FT.	64.90 SQ.M.
BALCONY AREA	141.98 SQ.FT.	13.19 SQ.M.
TOTAL AREA	840.56 SQ.FT.	78.09 SQ.M.

KEY PLAN LEVEL

04-05

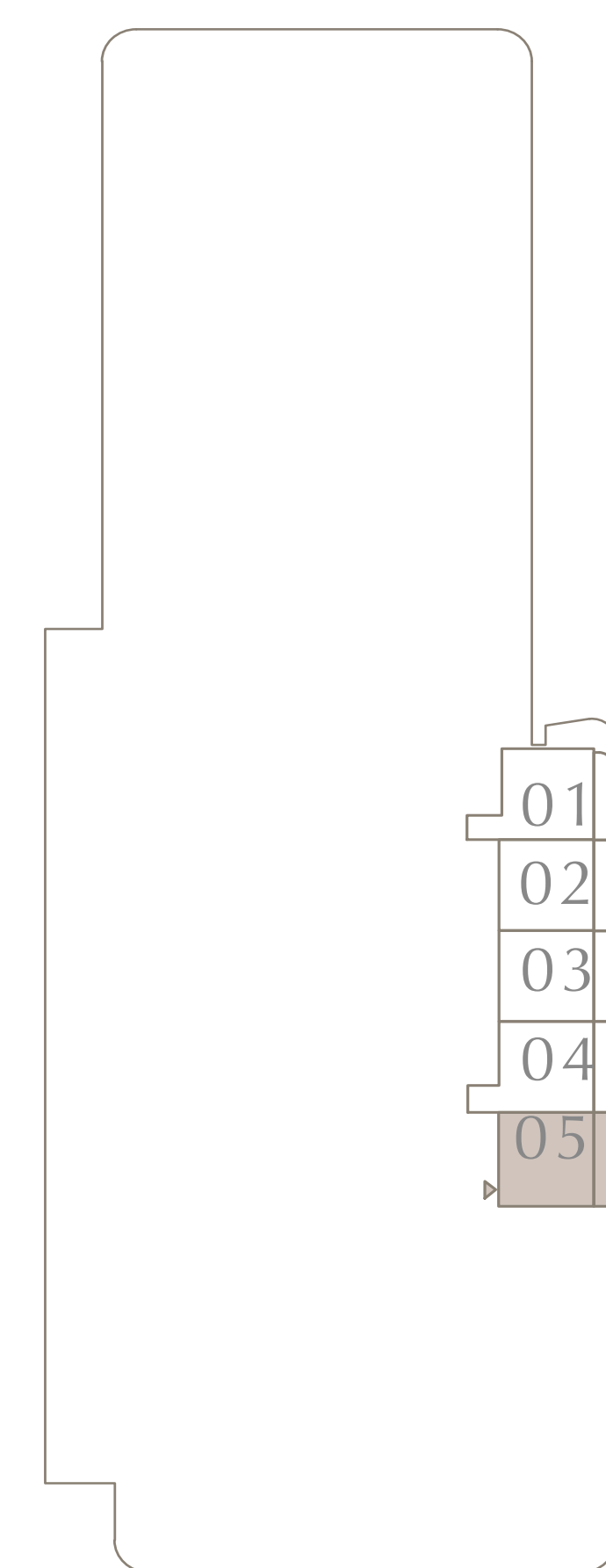
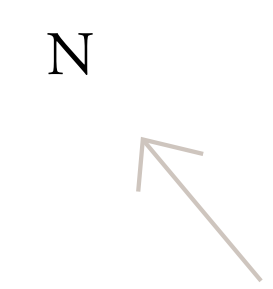

KEY SECTION

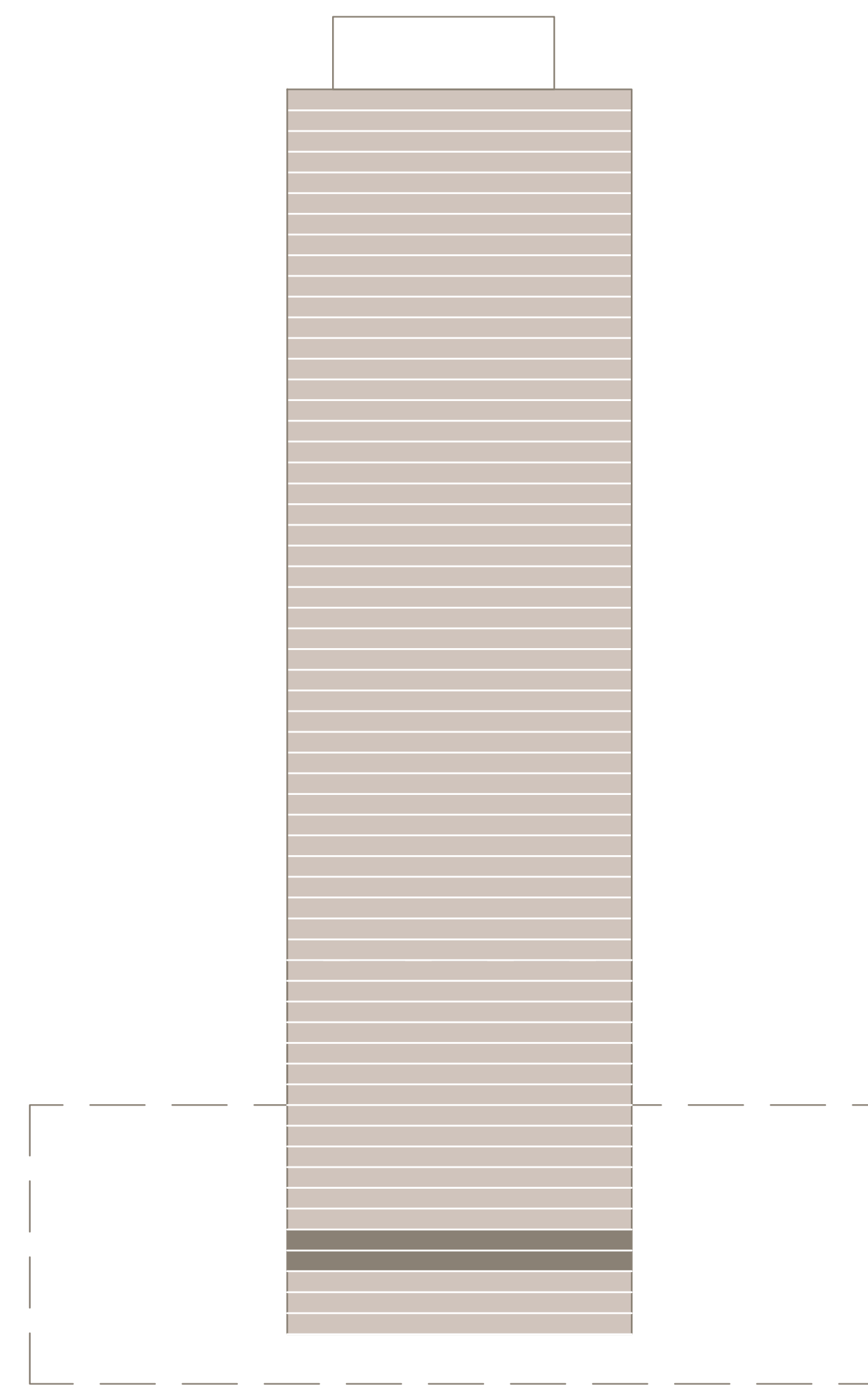

Disclaimer : All dimensions are in imperial and metric, and measured from finish to finish excluding construction tolerances. 2. All materials, dimensions, and drawings are approximate only. 3. Information is subject to change without notice, at developer's absolute discretion. 4. Actual area may vary from the stated area. 5. Drawings not to scale. 6. All images used are for illustrative purposes only and do not represent the actual size, features, specifications, fittings, and furnishings. 7. The developer reserves the right to make revisions / alterations, at its absolute discretion, without any liability whatsoever.



# ADDRESS RESIDENCES THE BAY

## 1 BEDROOM TYPE A 9

LEVEL 05 |

UNIT 01

SUITE AREA	786.20 SQ.FT.	73.04 SQ.M.
BALCONY AREA	131.43 SQ.FT.	12.21 SQ.M.
TOTAL AREA	917.63 SQ.FT.	85.25 SQ.M.

KEY PLAN LEVEL

05

KEY SECTION

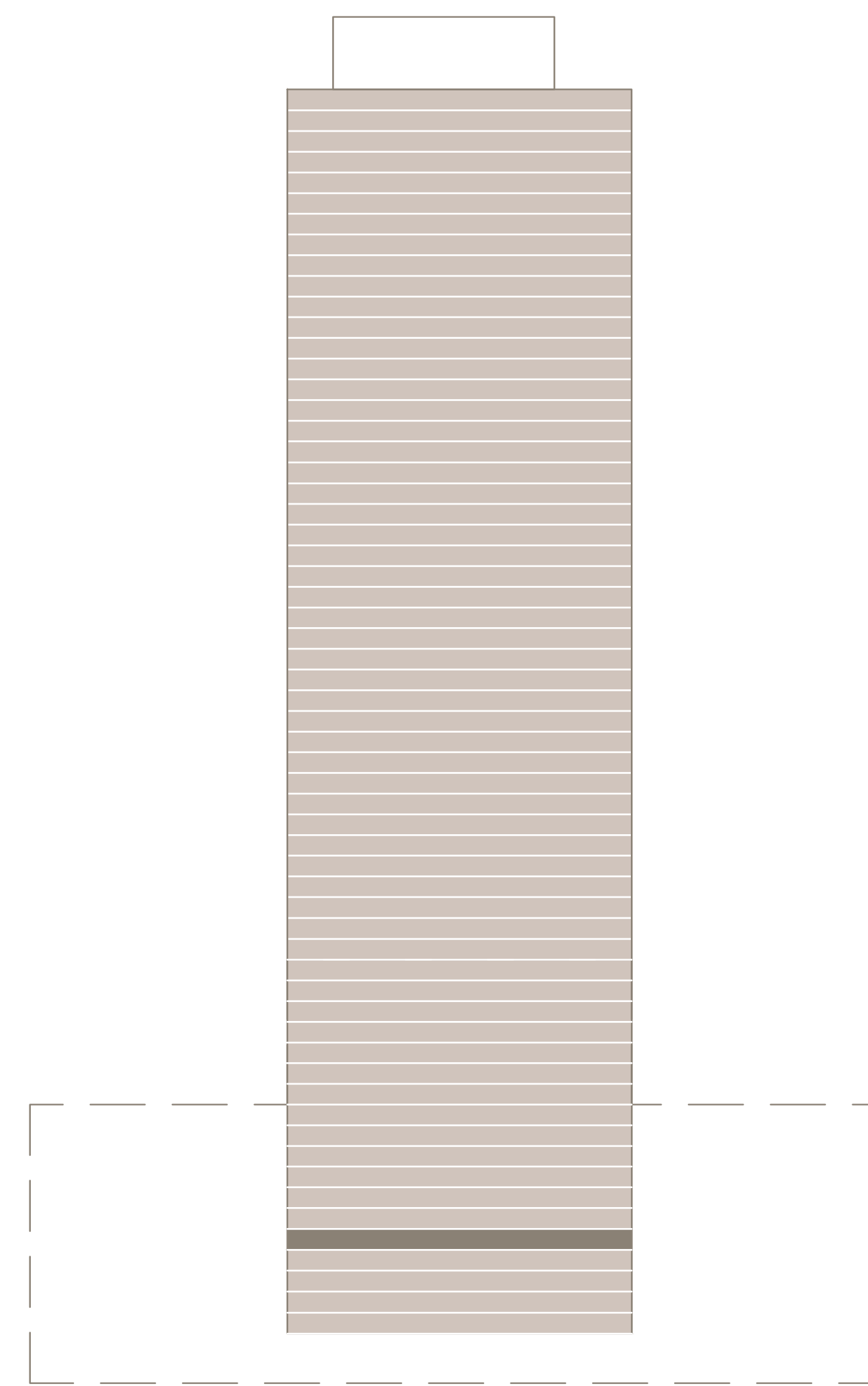
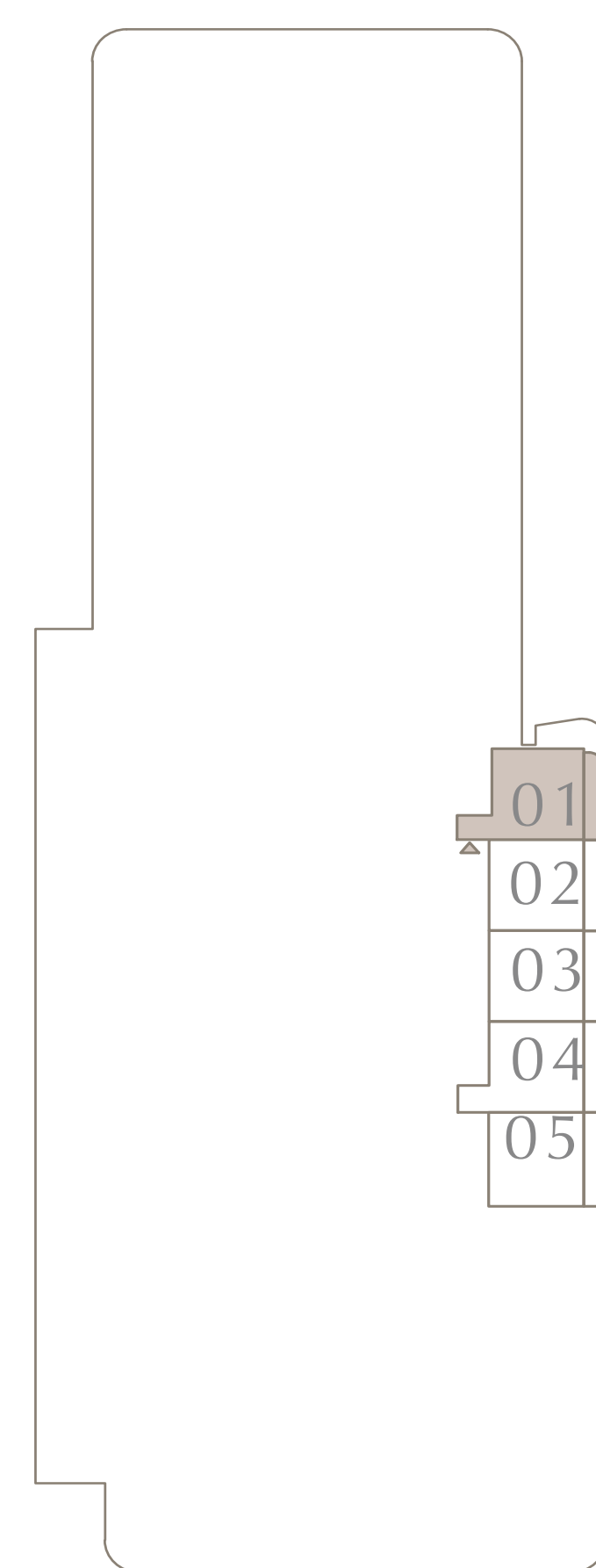
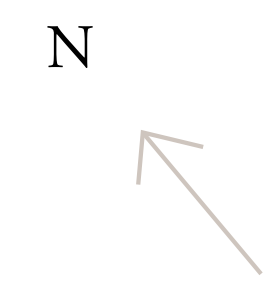

Disclaimer : All dimensions are in imperial and metric, and measured from finish to finish excluding construction tolerances. 2. All materials, dimensions, and drawings are approximate only. 3. Information is subject to change without notice, at developer's absolute discretion. 4. Actual area may vary from the stated area. 5. Drawings not to scale. 6. All images used are for illustrative purposes only and do not represent the actual size, features, specifications, fittings, and furnishings. 7. The developer reserves the right to make revisions / alterations, at its absolute discretion, without any liability whatsoever.



# ADDRESS RESIDENCES THE BAY

## 1 BEDROOM TYPE A 10

LEVEL 05 | UNIT 04

SUITE AREA	765.74 SQ.FT.	71.14 SQ.M.
BALCONY AREA	141.98 SQ.FT.	13.19 SQ.M.
TOTAL AREA	907.72 SQ.FT.	84.33 SQ.M.

KEY PLAN LEVEL  
05

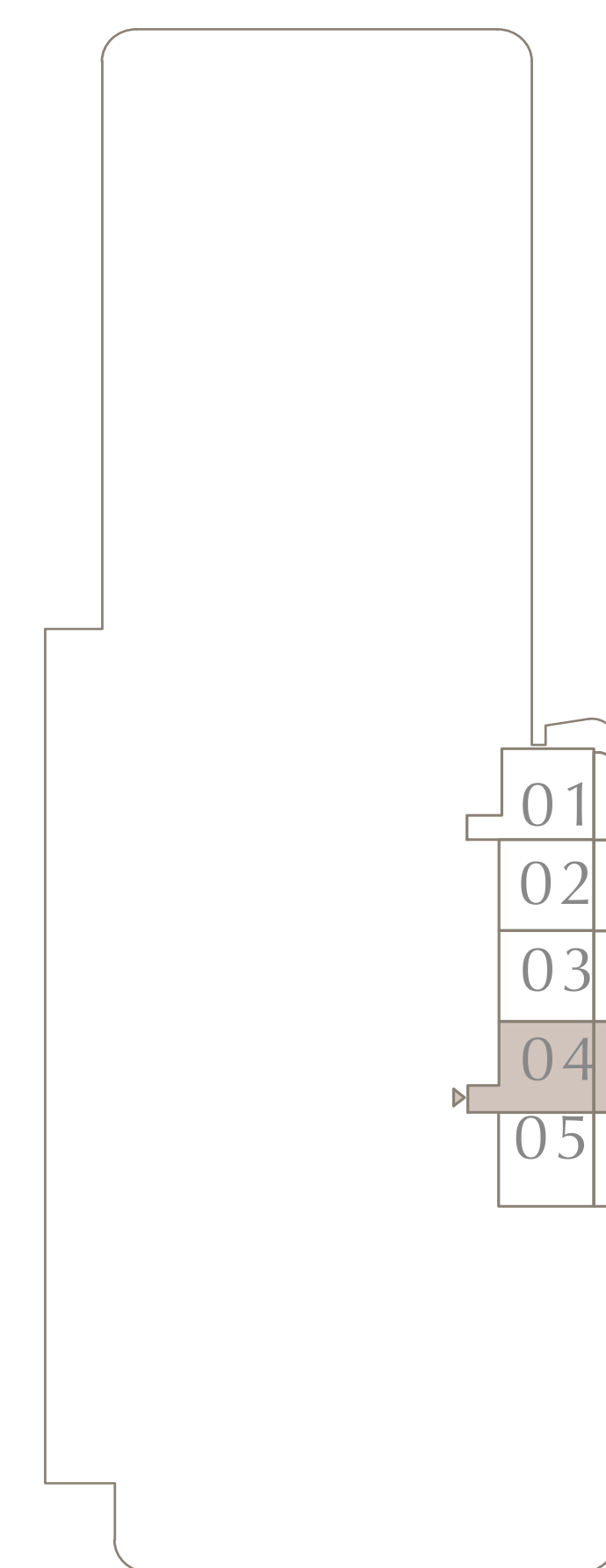
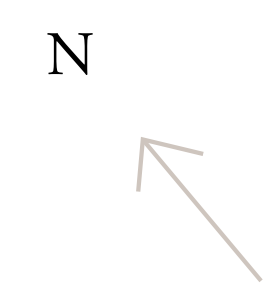

KEY SECTION

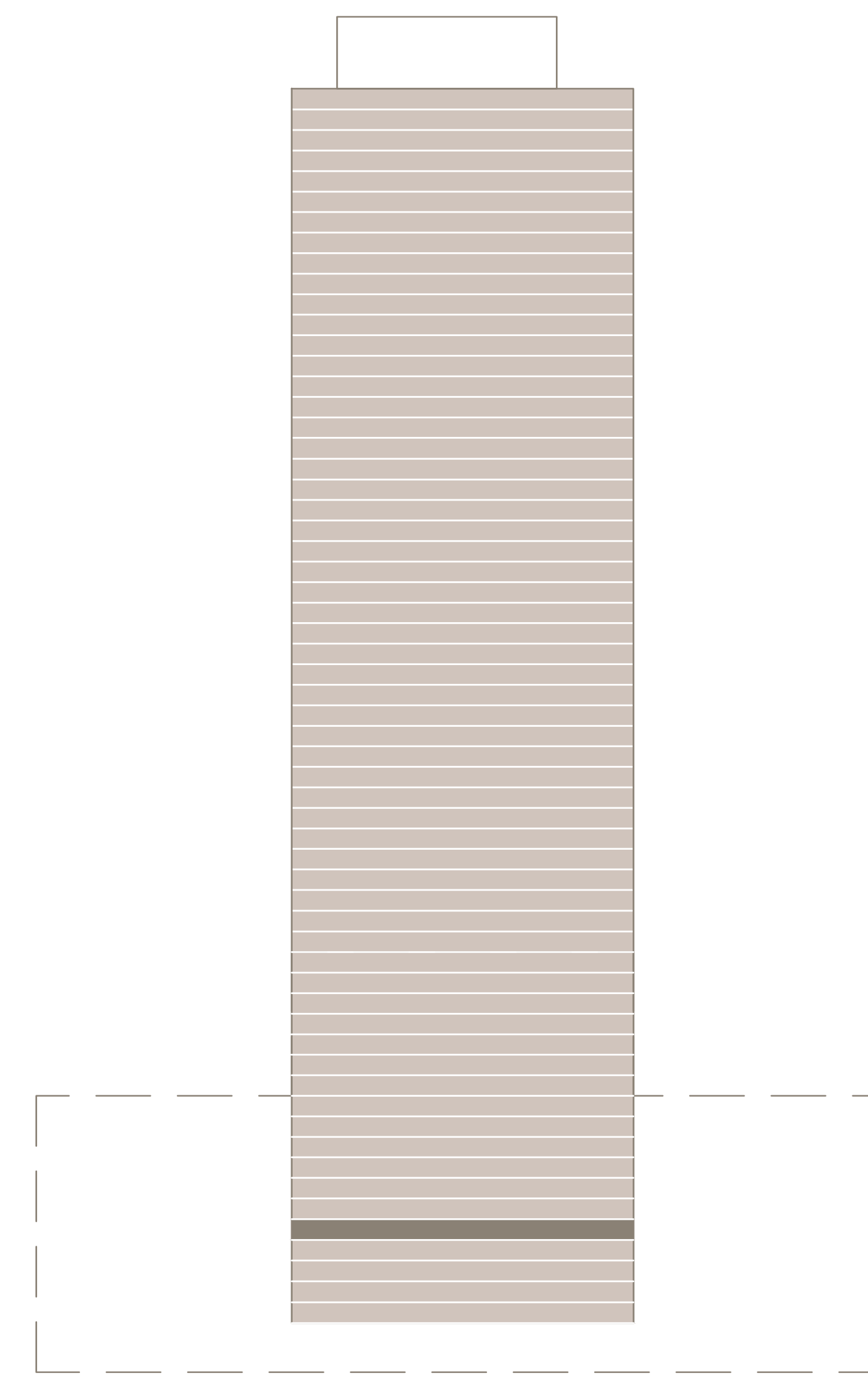

Disclaimer : All dimensions are in imperial and metric, and measured from finish to finish excluding construction tolerances. 2. All materials, dimensions, and drawings are approximate only. 3. Information is subject to change without notice, at developer's absolute discretion. 4. Actual area may vary from the stated area. 5. Drawings not to scale. 6. All images used are for illustrative purposes only and do not represent the actual size, features, specifications, fittings, and furnishings. 7. The developer reserves the right to make revisions / alterations, at its absolute discretion, without any liability whatsoever.



# ADDRESS RESIDENCES THE BAY

## 1 BEDROOM TYPE A 9

LEVEL 06 |

UNIT 01

SUITE AREA	786.52 SQ.FT.	73.07 SQ.M.
BALCONY AREA	131.43 SQ.FT.	12.21 SQ.M.
TOTAL AREA	917.95 SQ.FT.	85.28 SQ.M.

KEY PLAN LEVEL

06

KEY SECTION

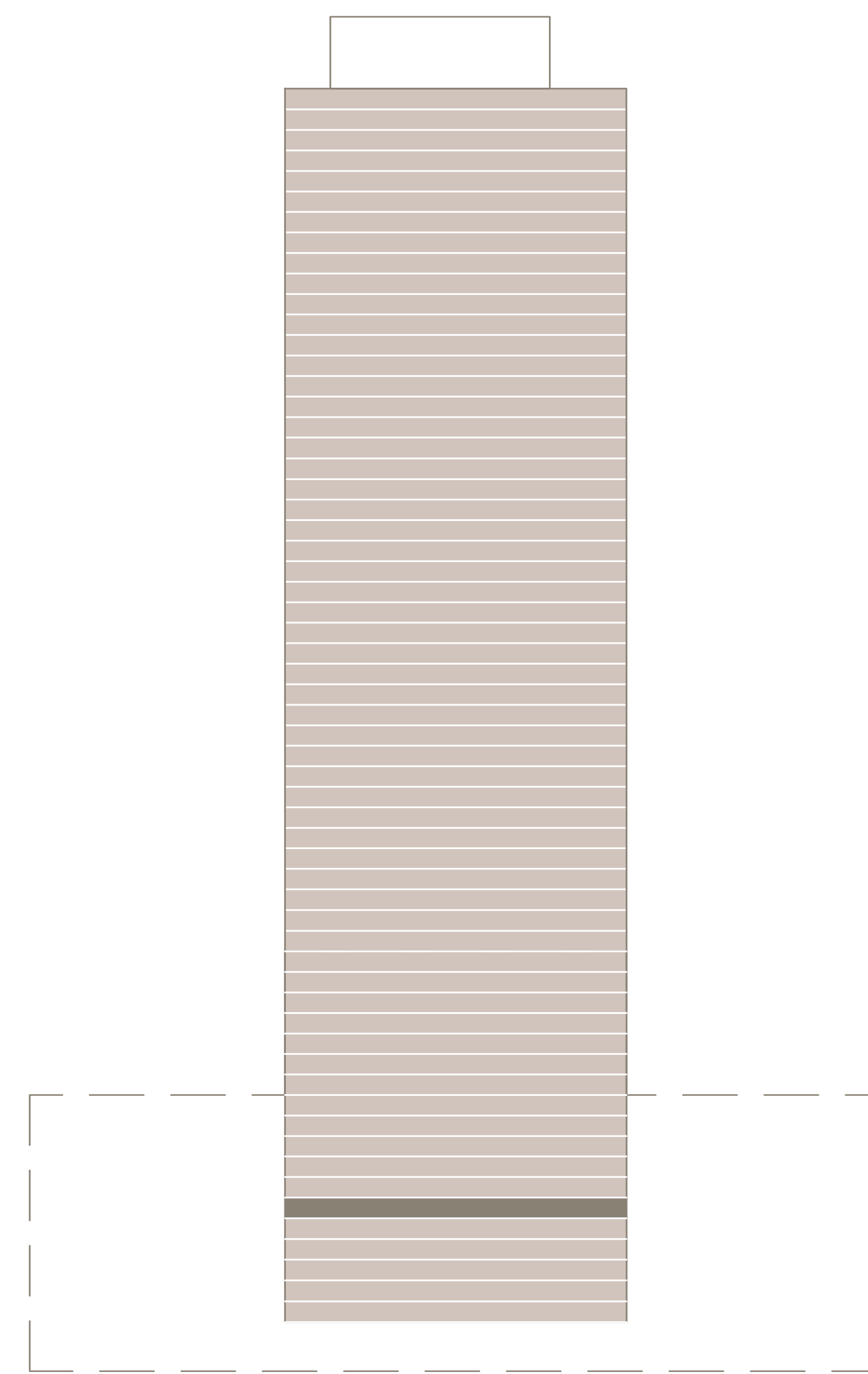
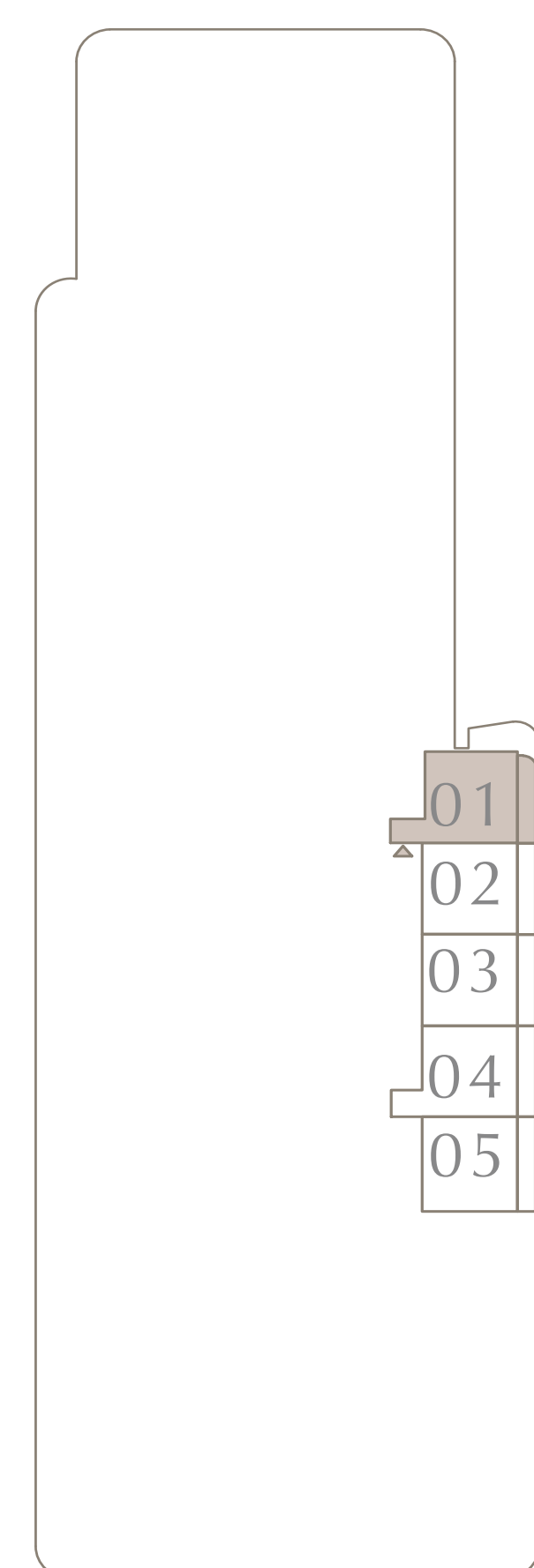
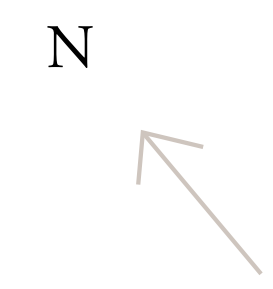

Disclaimer : All dimensions are in imperial and metric, and measured from finish to finish excluding construction tolerances. 2. All materials, dimensions, and drawings are approximate only. 3. Information is subject to change without notice, at developer's absolute discretion. 4. Actual area may vary from the stated area. 5. Drawings not to scale. 6. All images used are for illustrative purposes only and do not represent the actual size, features, specifications, fittings, and furnishings. 7. The developer reserves the right to make revisions / alterations, at its absolute discretion, without any liability whatsoever.



# ADDRESS RESIDENCES THE BAY

## 1 BEDROOM TYPE A 8

LEVEL 06 | UNIT 02

SUITE AREA	698.36 SQ.FT.	64.88 SQ.M.
BALCONY AREA	141.98 SQ.FT.	13.19 SQ.M.
TOTAL AREA	840.34 SQ.FT.	78.07 SQ.M.

KEY PLAN LEVEL

06

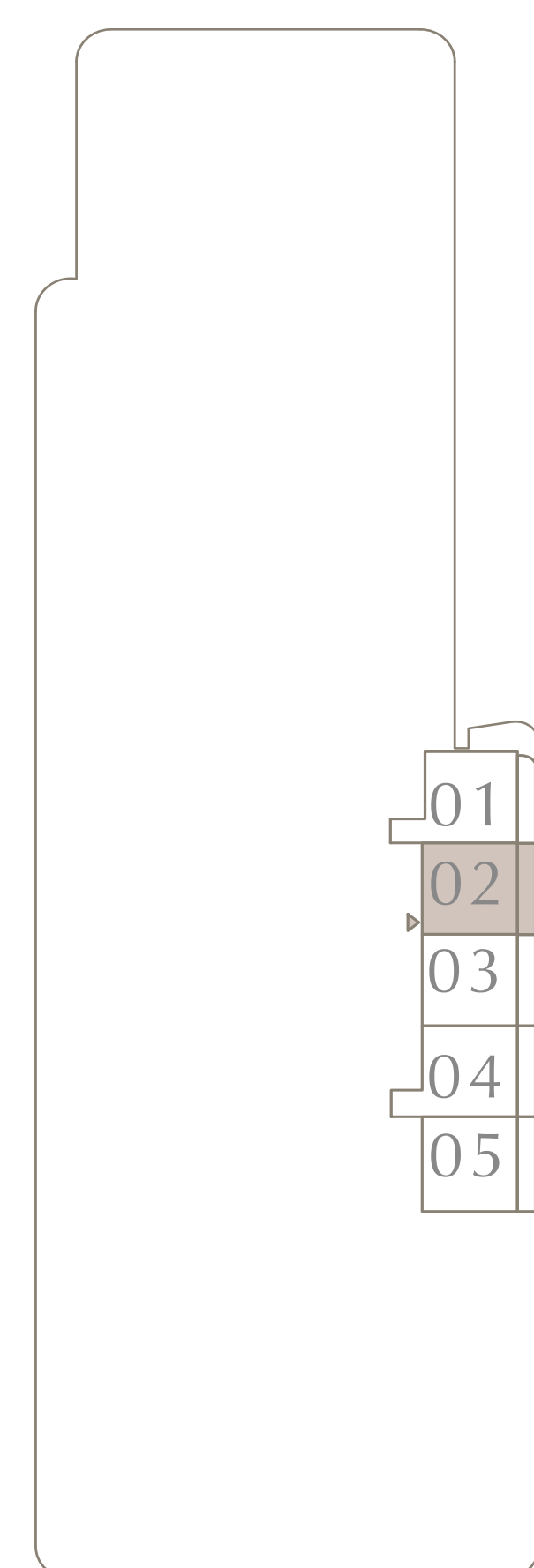
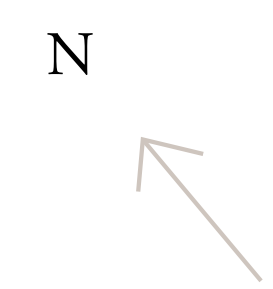

KEY SECTION

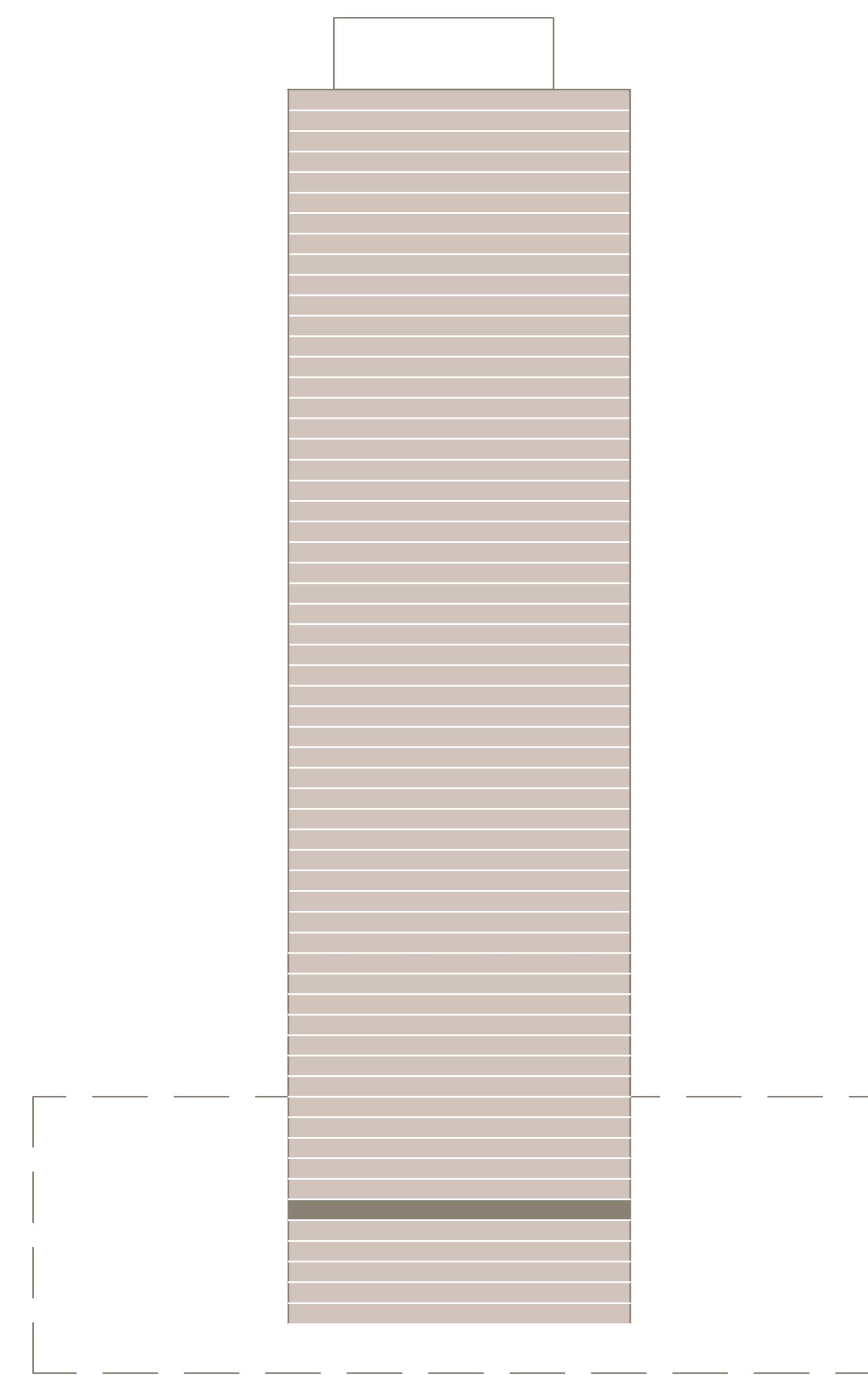

Disclaimer : All dimensions are in imperial and metric, and measured from finish to finish excluding construction tolerances. 2. All materials, dimensions, and drawings are approximate only. 3. Information is subject to change without notice, at developer's absolute discretion. 4. Actual area may vary from the stated area. 5. Drawings not to scale. 6. All images used are for illustrative purposes only and do not represent the actual size, features, specifications, fittings, and furnishings. 7. The developer reserves the right to make revisions / alterations, at its absolute discretion, without any liability whatsoever.



# ADDRESS RESIDENCES THE BAY

## 1 BEDROOM TYPE A 8

LEVEL 06 | UNIT 03

SUITE AREA	702.99 SQ.FT.	65.31 SQ.M.
BALCONY AREA	141.98 SQ.FT.	13.19 SQ.M.
TOTAL AREA	844.97 SQ.FT.	78.50 SQ.M.

KEY PLAN LEVEL

06

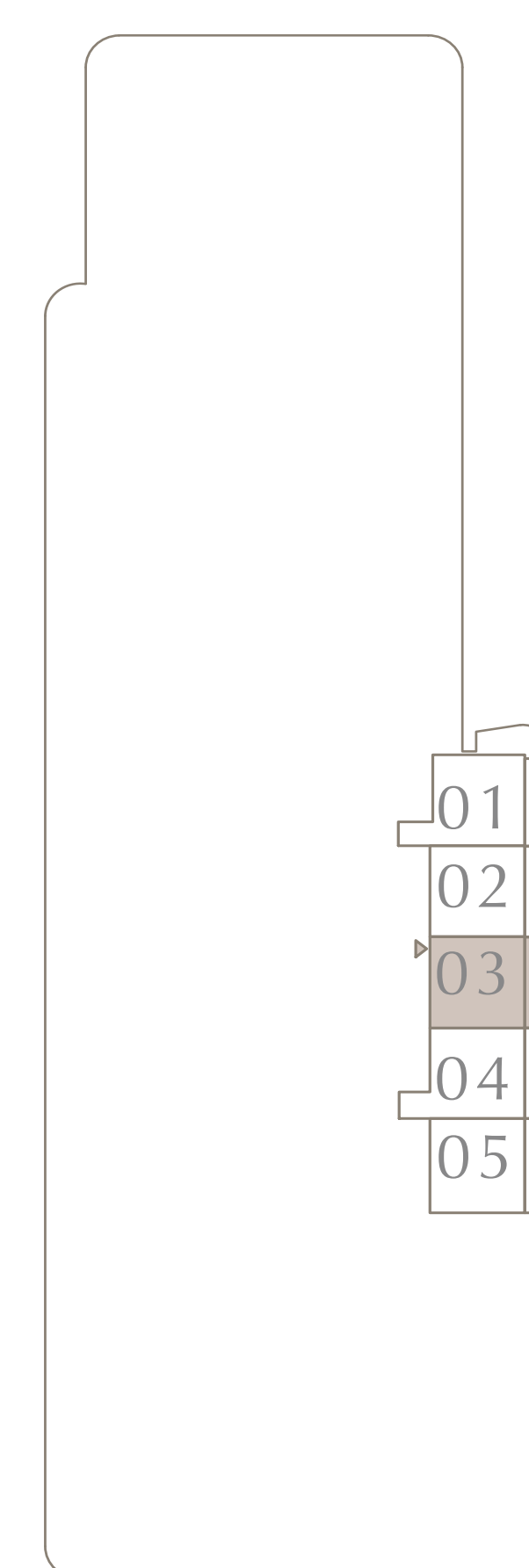
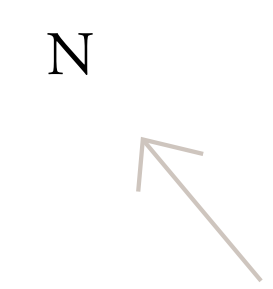

KEY SECTION

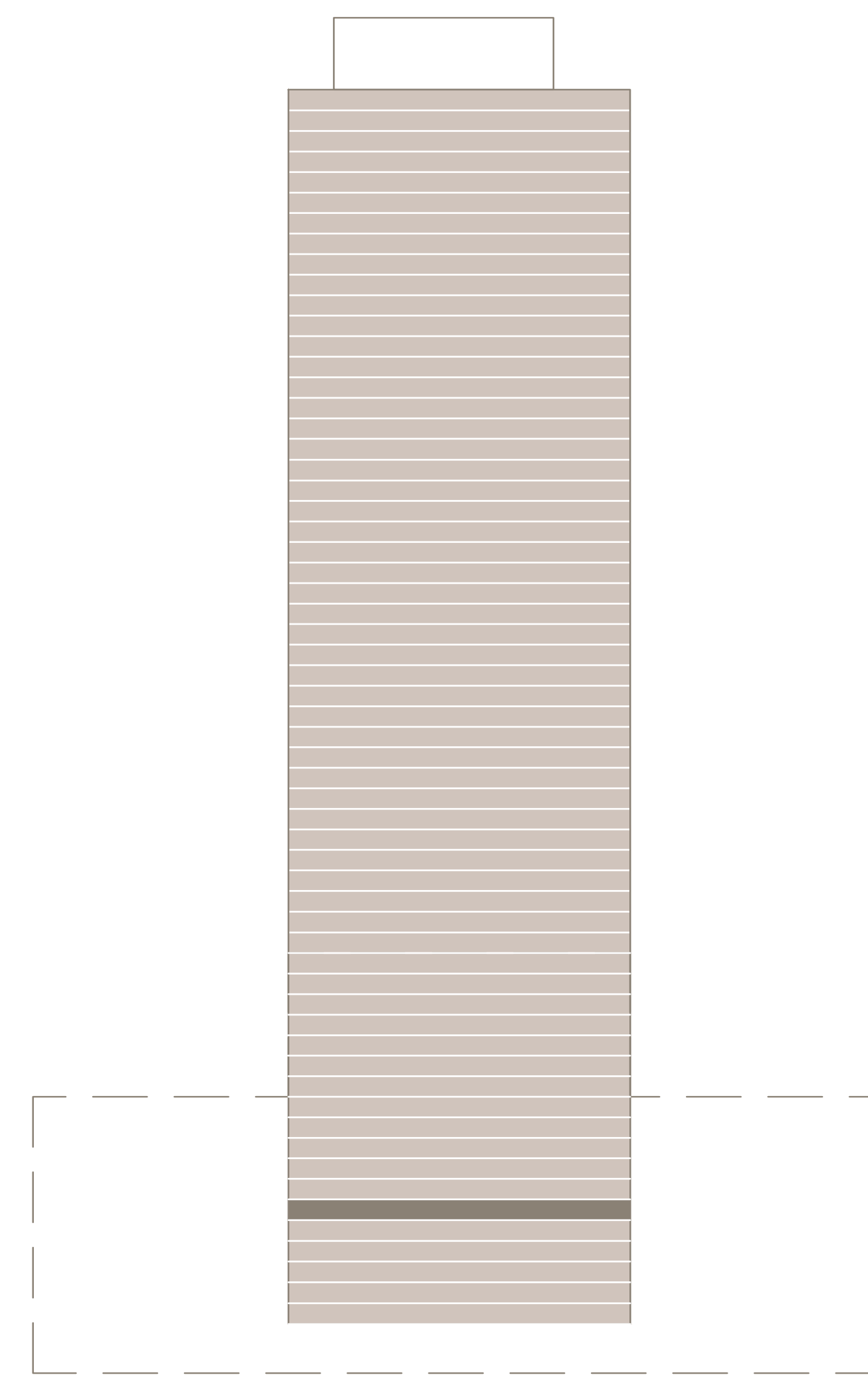

Disclaimer : All dimensions are in imperial and metric, and measured from finish to finish excluding construction tolerances. 2. All materials, dimensions, and drawings are approximate only. 3. Information is subject to change without notice, at developer's absolute discretion. 4. Actual area may vary from the stated area. 5. Drawings not to scale. 6. All images used are for illustrative purposes only and do not represent the actual size, features, specifications, fittings, and furnishings. 7. The developer reserves the right to make revisions / alterations, at its absolute discretion, without any liability whatsoever.



# ADDRESS RESIDENCES THE BAY

## 1 BEDROOM TYPE A 10

LEVEL 06 | UNIT 04

SUITE AREA	765.74 SQ.FT.	71.14 SQ.M.
BALCONY AREA	141.98 SQ.FT.	13.19 SQ.M.
TOTAL AREA	907.72 SQ.FT.	84.33 SQ.M.

KEY PLAN LEVEL

06

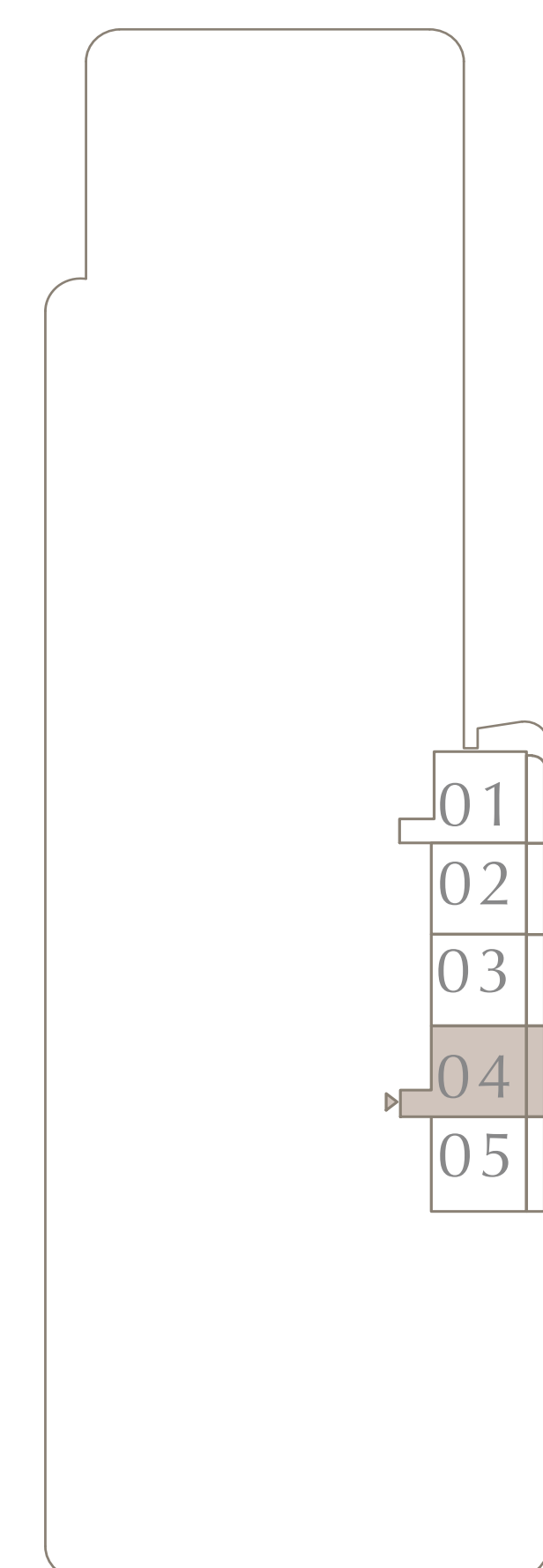
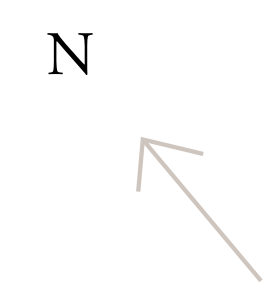

KEY SECTION

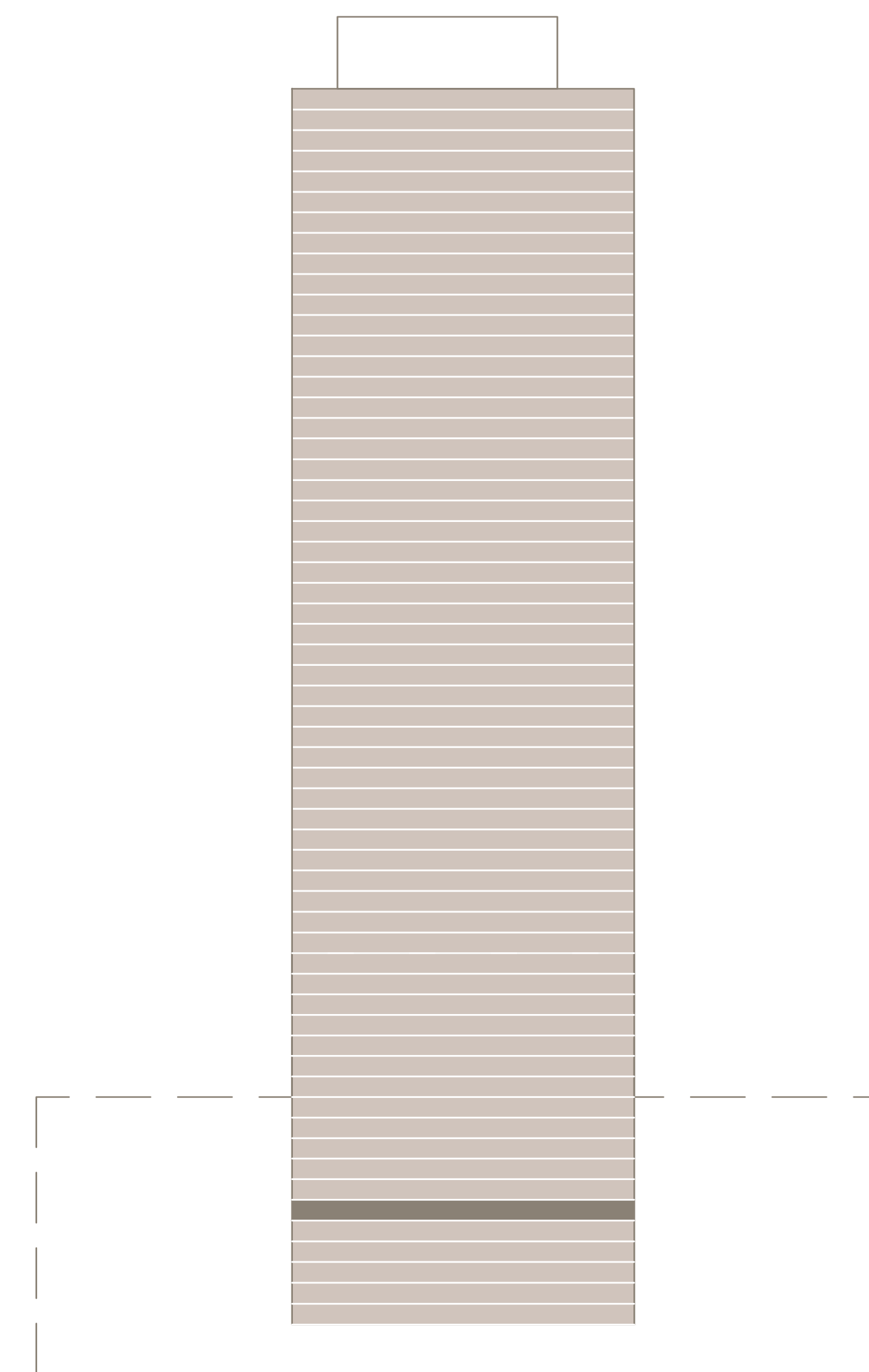

Disclaimer : All dimensions are in imperial and metric, and measured from finish to finish excluding construction tolerances. 2. All materials, dimensions, and drawings are approximate only. 3. Information is subject to change without notice, at developer's absolute discretion. 4. Actual area may vary from the stated area. 5. Drawings not to scale. 6. All images used are for illustrative purposes only and do not represent the actual size, features, specifications, fittings, and furnishings. 7. The developer reserves the right to make revisions / alterations, at its absolute discretion, without any liability whatsoever.



# ADDRESS RESIDENCES THE BAY

## 1 BEDROOM TYPE A 8

LEVEL 06 |

UNIT 05

SUITE AREA	698.58 SQ.FT.	64.90 SQ.M.
BALCONY AREA	141.98 SQ.FT.	13.19 SQ.M.
TOTAL AREA	840.56 SQ.FT.	78.09 SQ.M.

KEY PLAN LEVEL

06

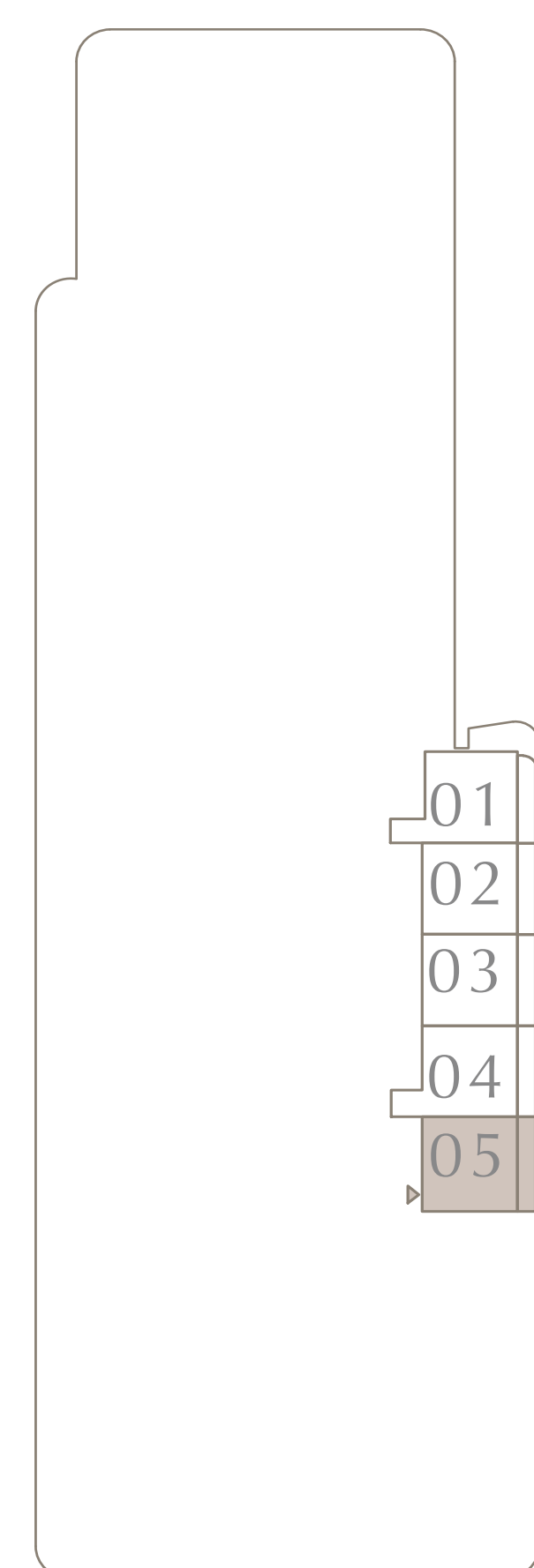
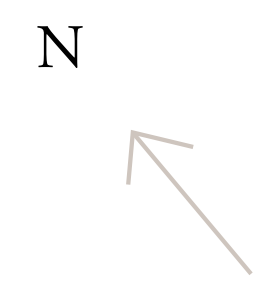

KEY SECTION

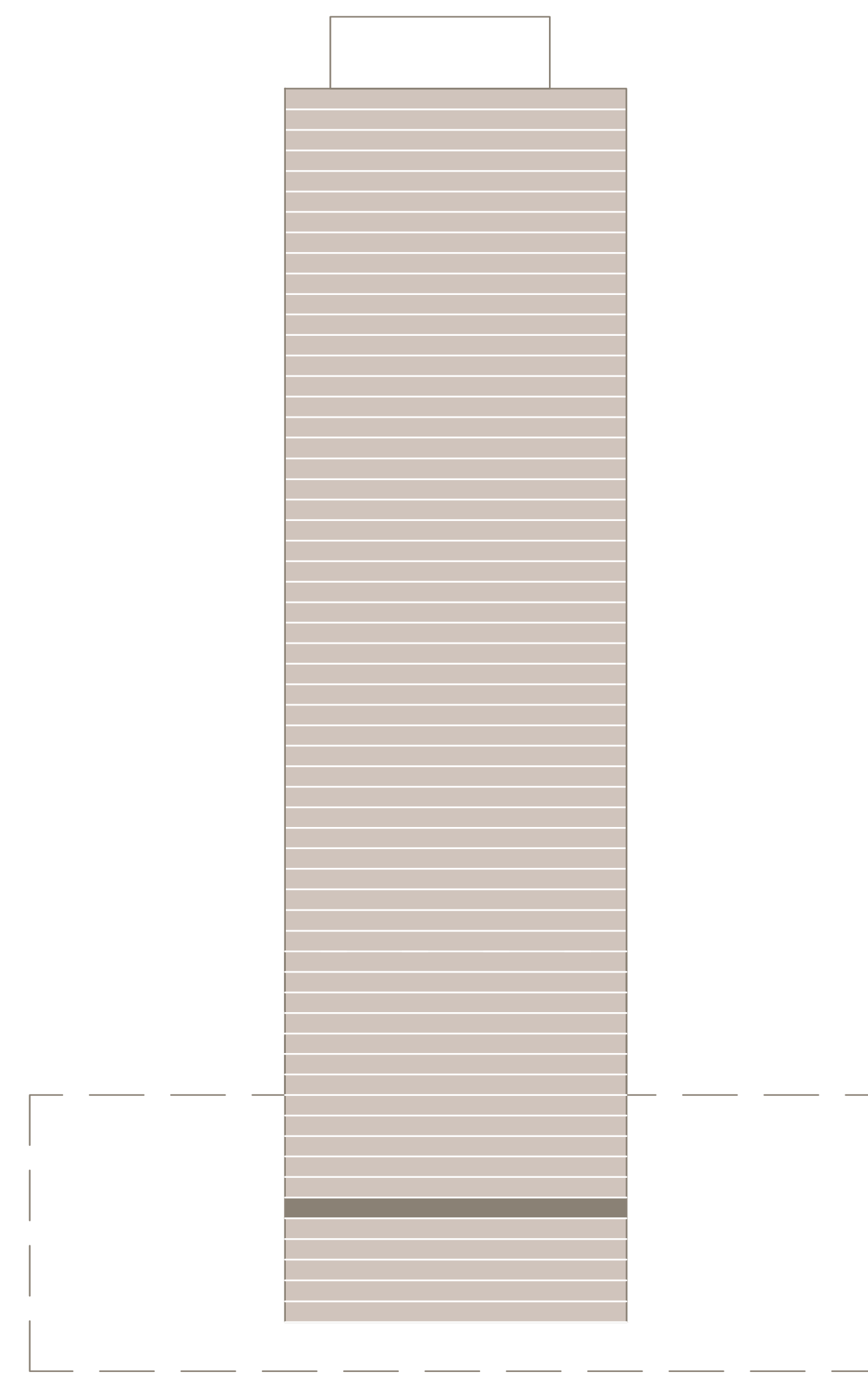

Disclaimer : All dimensions are in imperial and metric, and measured from finish to finish excluding construction tolerances. 2. All materials, dimensions, and drawings are approximate only. 3. Information is subject to change without notice, at developer's absolute discretion. 4. Actual area may vary from the stated area. 5. Drawings not to scale. 6. All images used are for illustrative purposes only and do not represent the actual size, features, specifications, fittings, and furnishings. 7. The developer reserves the right to make revisions / alterations, at its absolute discretion, without any liability whatsoever.





# ADDRESS RESIDENCES THE BAY

## 1 BEDROOM TYPE A 9

LEVEL 07 | UNIT 01

SUITE AREA	786.52 SQ.FT.	73.07 SQ.M.
BALCONY AREA	131.21 SQ.FT.	12.19 SQ.M.
TOTAL AREA	917.73 SQ.FT.	85.26 SQ.M.

KEY PLAN LEVEL

07

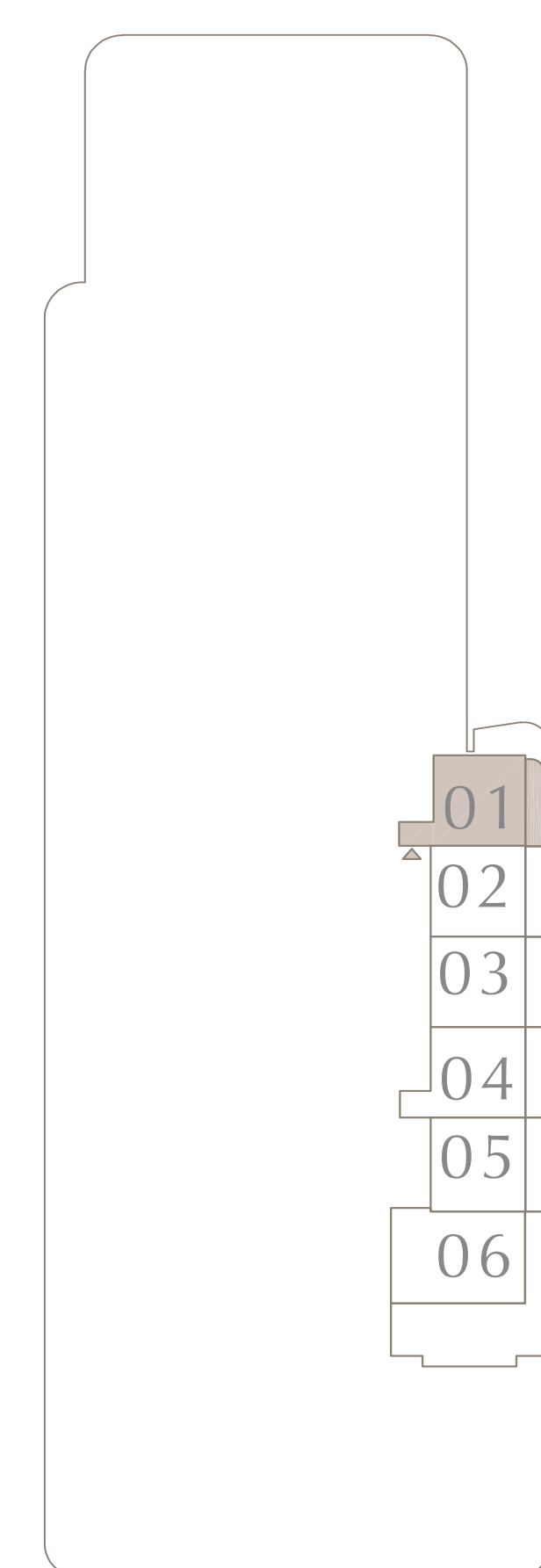
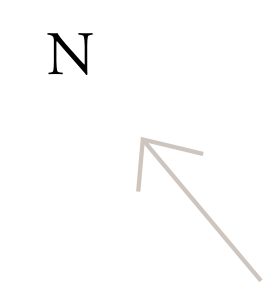

KEY SECTION

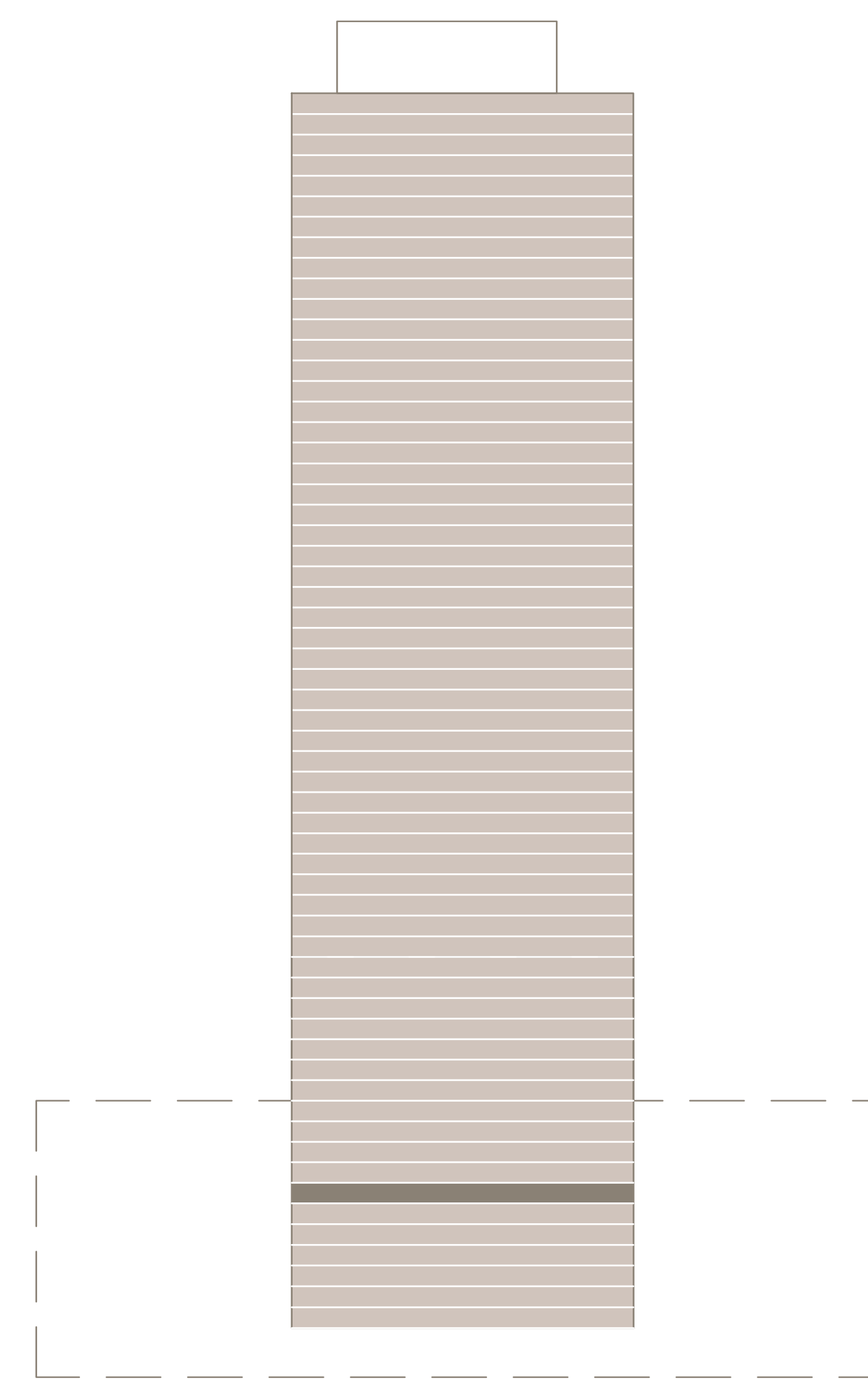

Disclaimer : All dimensions are in imperial and metric, and measured from finish to finish excluding construction tolerances. 2. All materials, dimensions, and drawings are approximate only. 3. Information is subject to change without notice, at developer's absolute discretion. 4. Actual area may vary from the stated area. 5. Drawings not to scale. 6. All images used are for illustrative purposes only and do not represent the actual size, features, specifications, fittings, and furnishings. 7. The developer reserves the right to make revisions / alterations, at its absolute discretion, without any liability whatsoever.



# ADDRESS RESIDENCES THE BAY

## 1 BEDROOM TYPE A 8

LEVEL 07 | UNIT 02

SUITE AREA	698.36 SQ.FT.	64.88 SQ.M.
BALCONY AREA	141.65 SQ.FT.	13.16 SQ.M.
TOTAL AREA	840.01 SQ.FT.	78.04 SQ.M.

KEY PLAN LEVEL

07

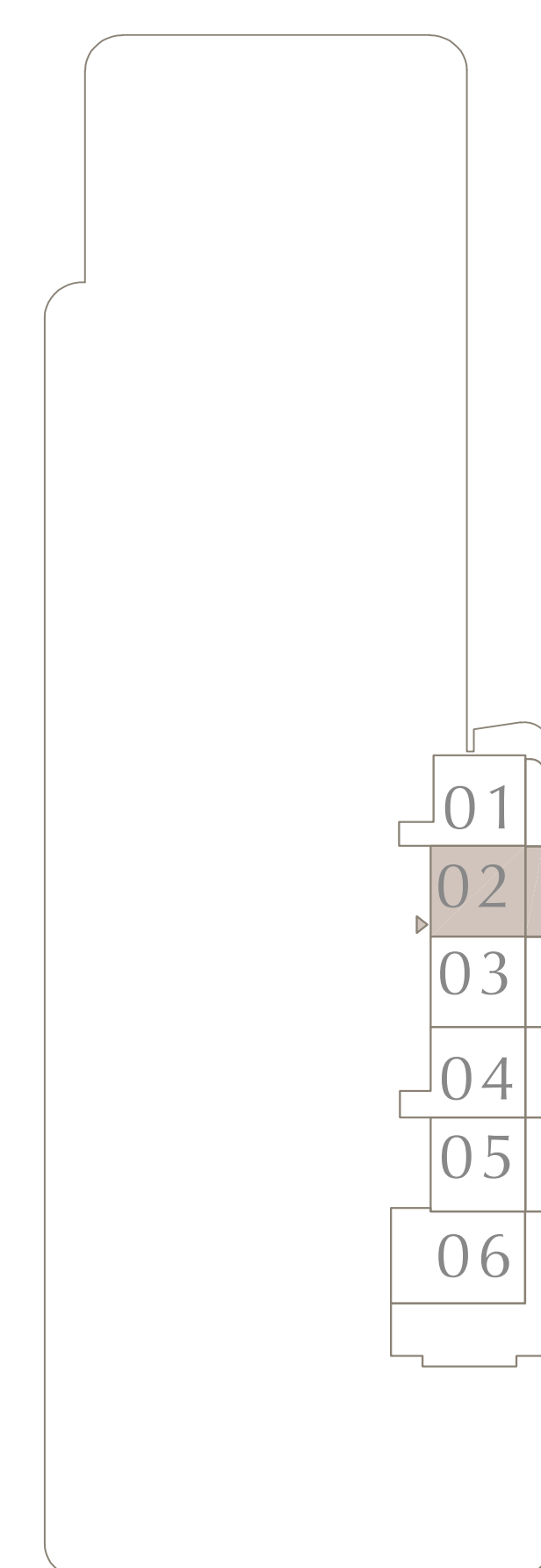
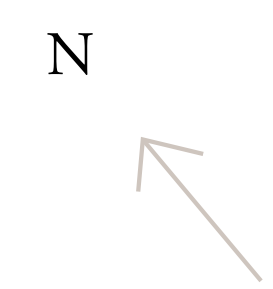

KEY SECTION

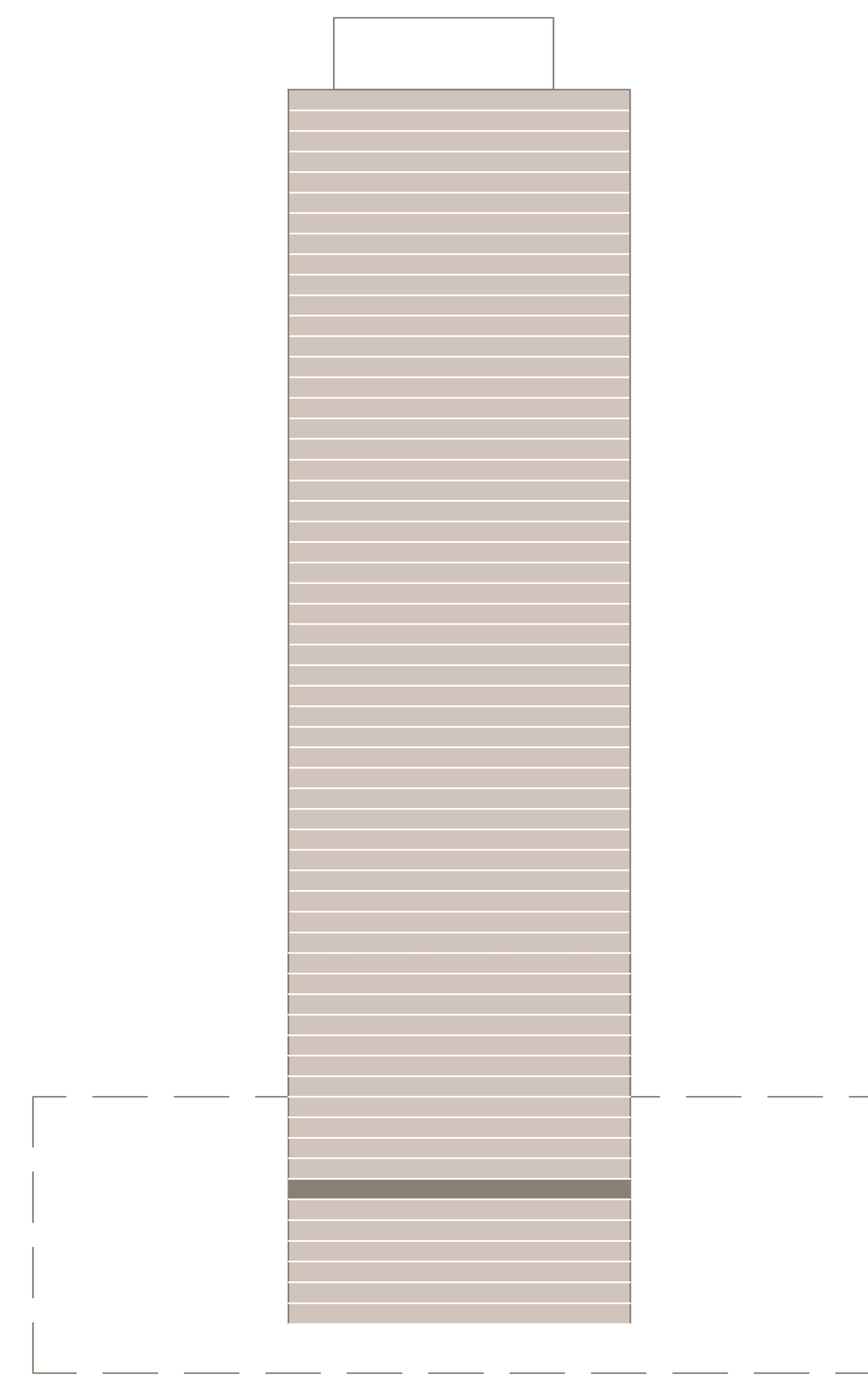

Disclaimer : All dimensions are in imperial and metric, and measured from finish to finish excluding construction tolerances. 2. All materials, dimensions, and drawings are approximate only. 3. Information is subject to change without notice, at developer's absolute discretion. 4. Actual area may vary from the stated area. 5. Drawings not to scale. 6. All images used are for illustrative purposes only and do not represent the actual size, features, specifications, fittings, and furnishings. 7. The developer reserves the right to make revisions / alterations, at its absolute discretion, without any liability whatsoever.



# ADDRESS RESIDENCES THE BAY

## 1 BEDROOM TYPE A 8

LEVEL 07 |

UNIT 03

SUITE AREA	702.99 SQ.FT.	65.31 SQ.M.
BALCONY AREA	141.65 SQ.FT.	13.16 SQ.M.
TOTAL AREA	844.64 SQ.FT.	78.47 SQ.M.

KEY PLAN LEVEL

07

KEY SECTION

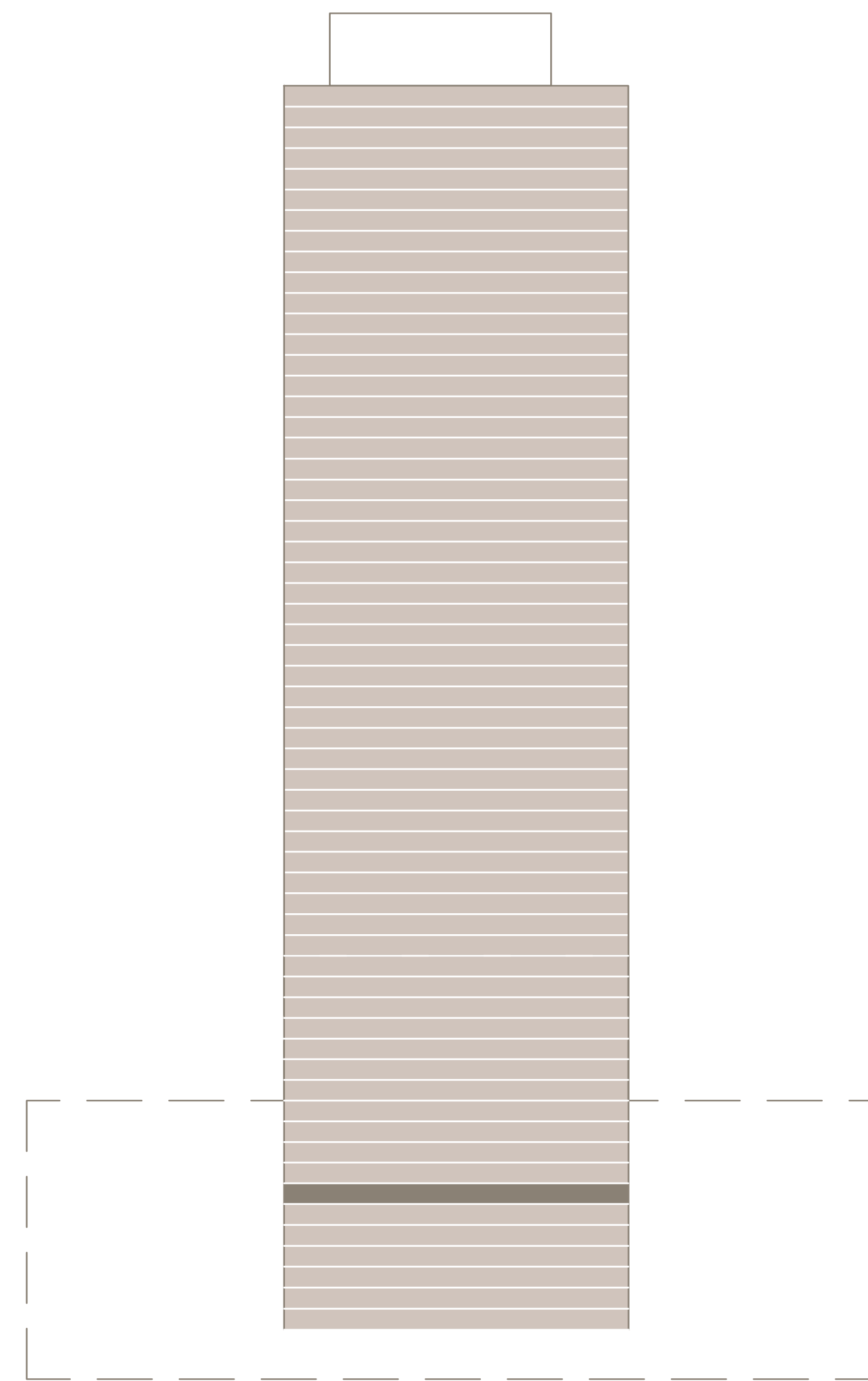
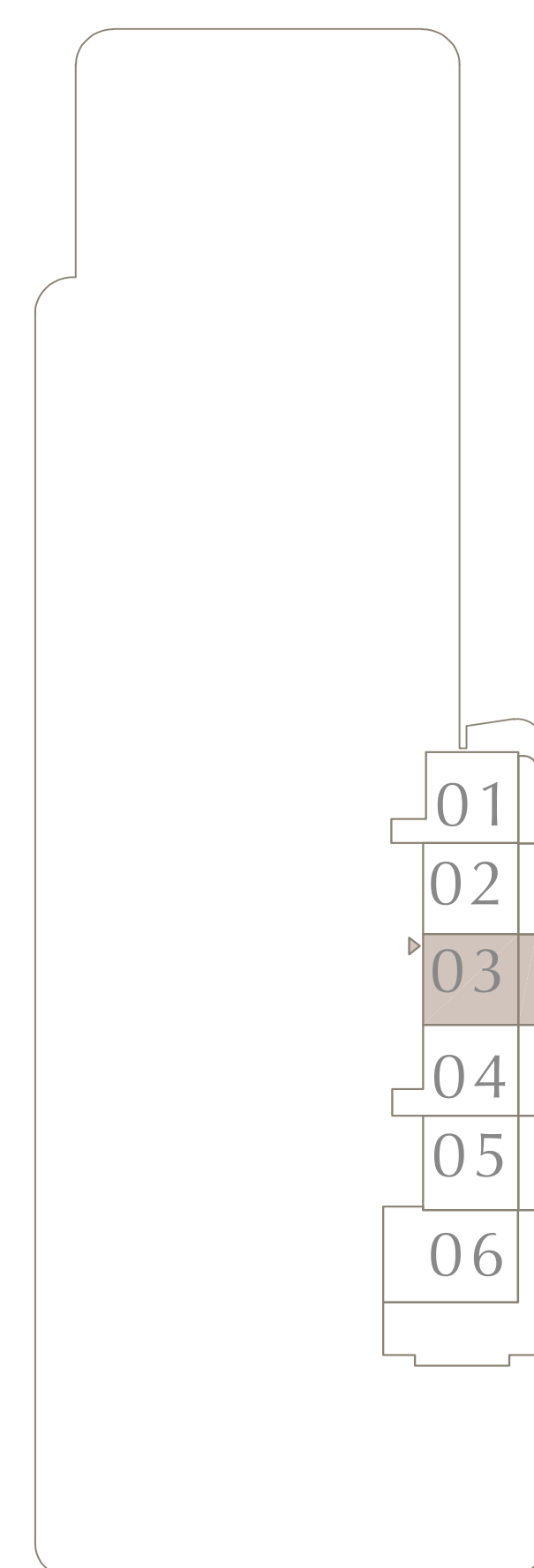
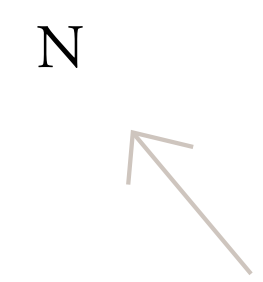

Disclaimer : All dimensions are in imperial and metric, and measured from finish to finish excluding construction tolerances. 2. All materials, dimensions, and drawings are approximate only. 3. Information is subject to change without notice, at developer's absolute discretion. 4. Actual area may vary from the stated area. 5. Drawings not to scale. 6. All images used are for illustrative purposes only and do not represent the actual size, features, specifications, fittings, and furnishings. 7. The developer reserves the right to make revisions / alterations, at its absolute discretion, without any liability whatsoever.



# ADDRESS RESIDENCES THE BAY

## 1 BEDROOM TYPE A 10

LEVEL 07 | UNIT 04

SUITE AREA	766.28 SQ.FT.	71.19 SQ.M.
BALCONY AREA	141.65 SQ.FT.	13.16 SQ.M.
TOTAL AREA	907.93 SQ.FT.	84.35 SQ.M.

KEY PLAN LEVEL

07

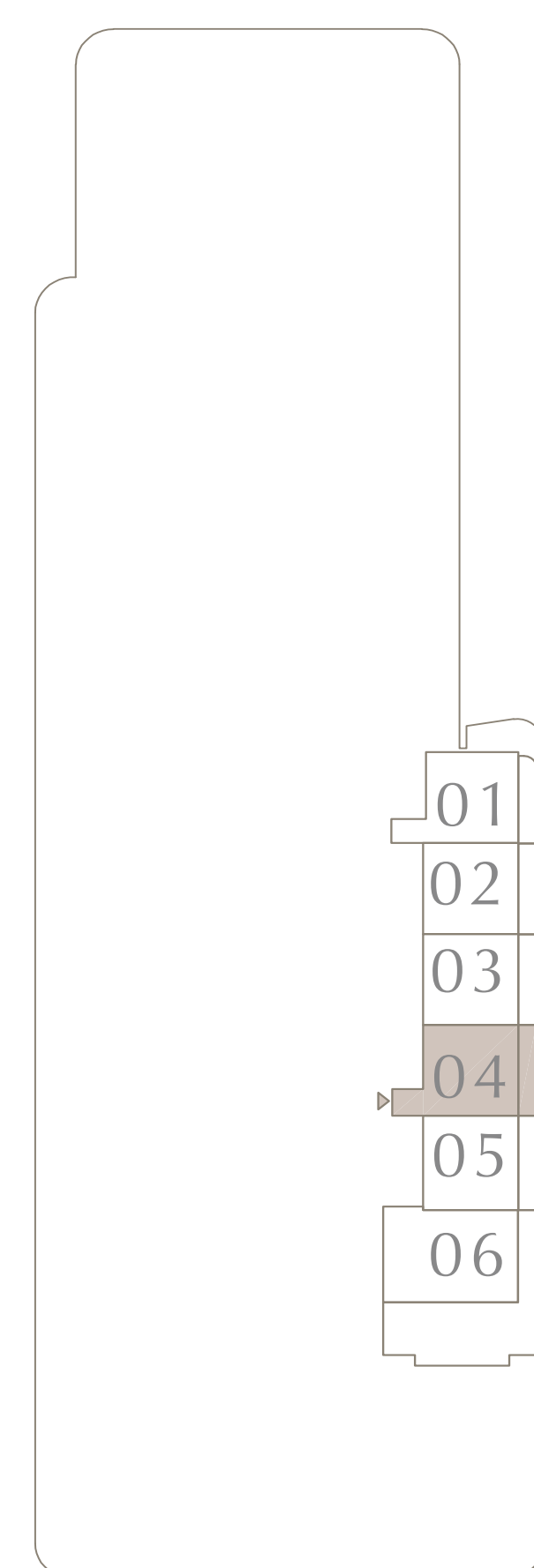
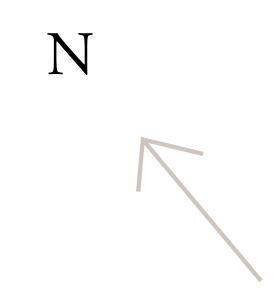

KEY SECTION

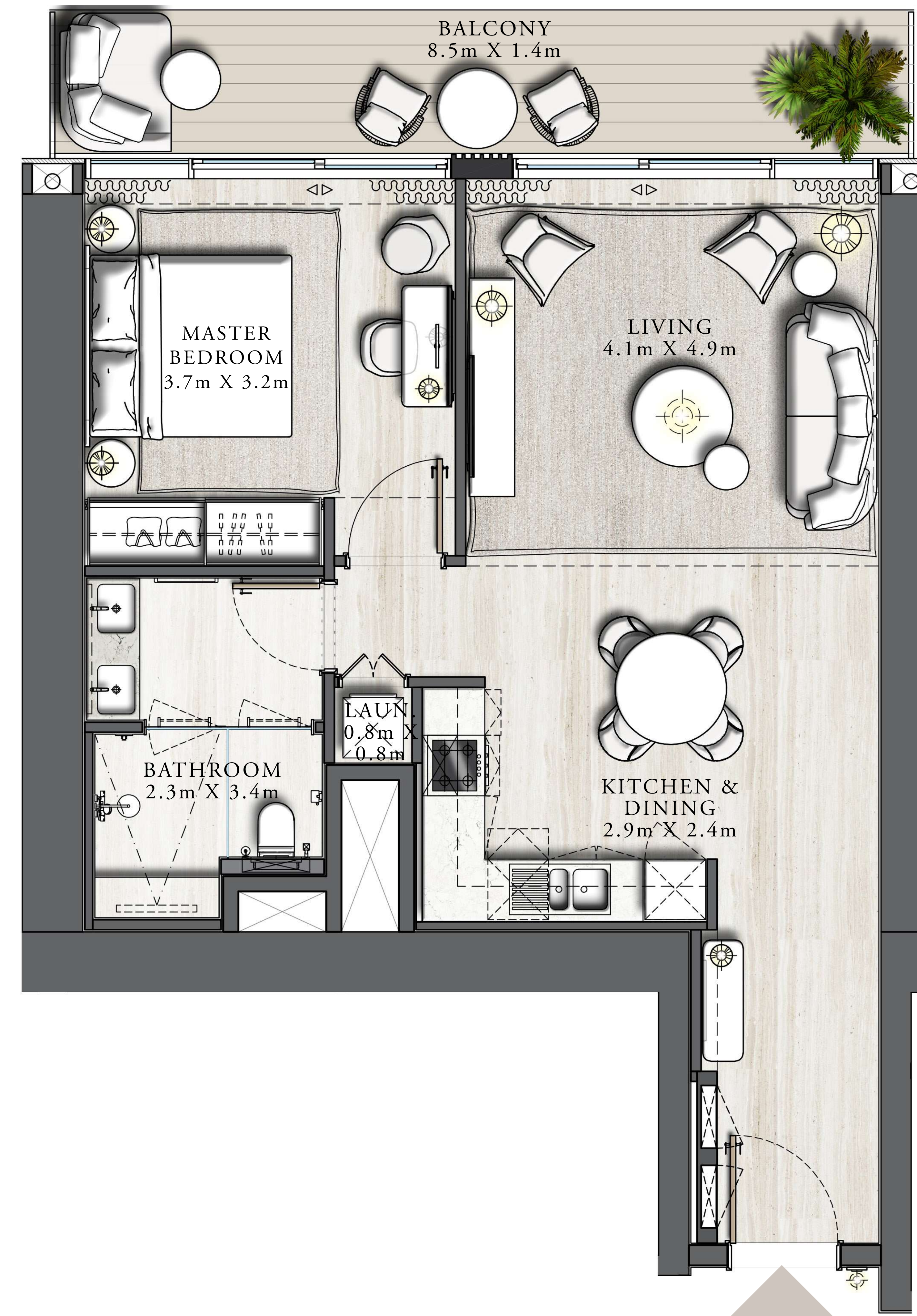
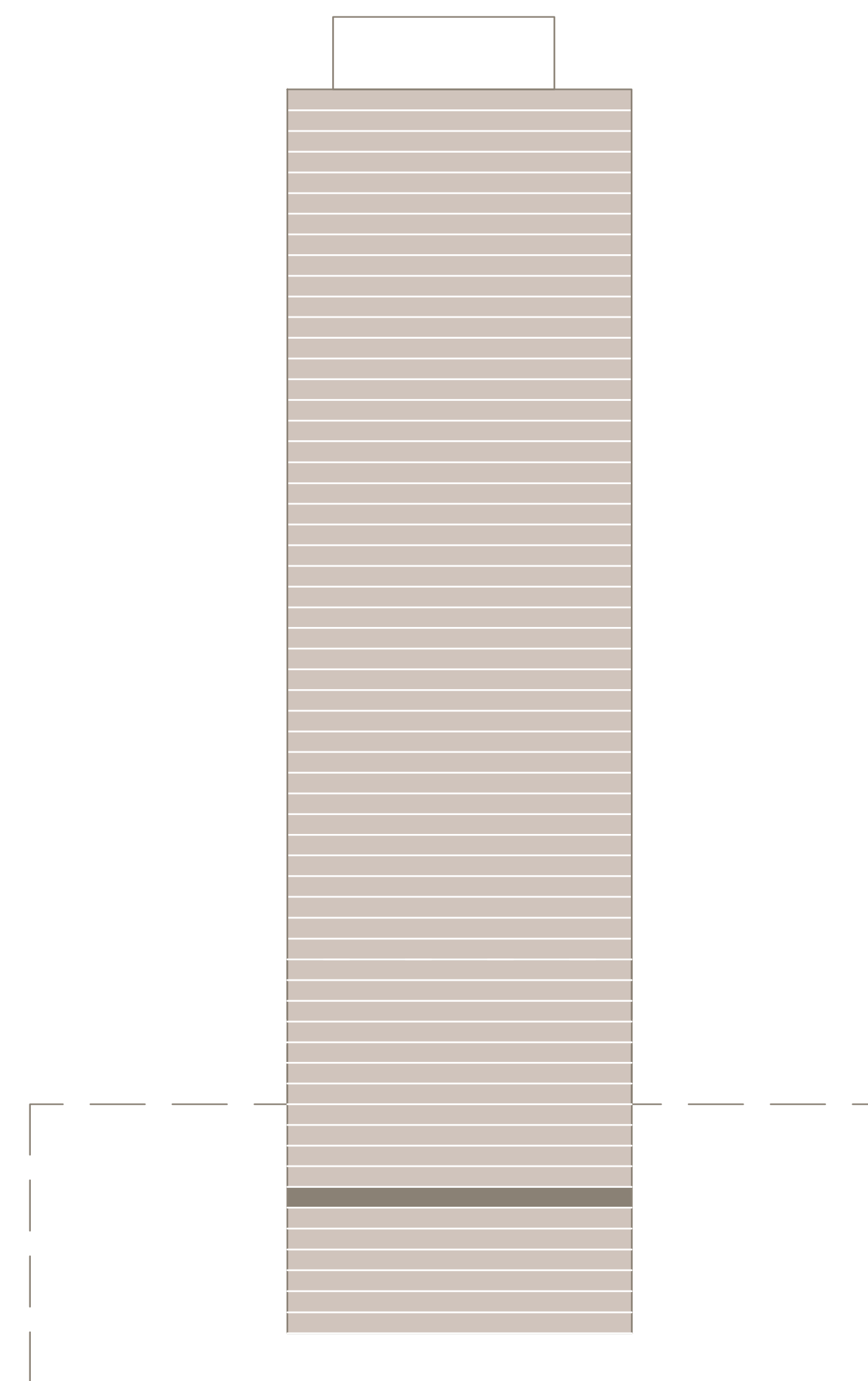

Disclaimer : All dimensions are in imperial and metric, and measured from finish to finish excluding construction tolerances. 2. All materials, dimensions, and drawings are approximate only. 3. Information is subject to change without notice, at developer's absolute discretion. 4. Actual area may vary from the stated area. 5. Drawings not to scale. 6. All images used are for illustrative purposes only and do not represent the actual size, features, specifications, fittings, and furnishings. 7. The developer reserves the right to make revisions / alterations, at its absolute discretion, without any liability whatsoever.



# ADDRESS RESIDENCES THE BAY

## 1 BEDROOM TYPE A 8

LEVEL 07 |

UNIT 05

SUITE AREA	698.69 SQ.FT.	64.91 SQ.M.
BALCONY AREA	141.65 SQ.FT.	13.16 SQ.M.
TOTAL AREA	840.34 SQ.FT.	78.07 SQ.M.

KEY PLAN LEVEL

07

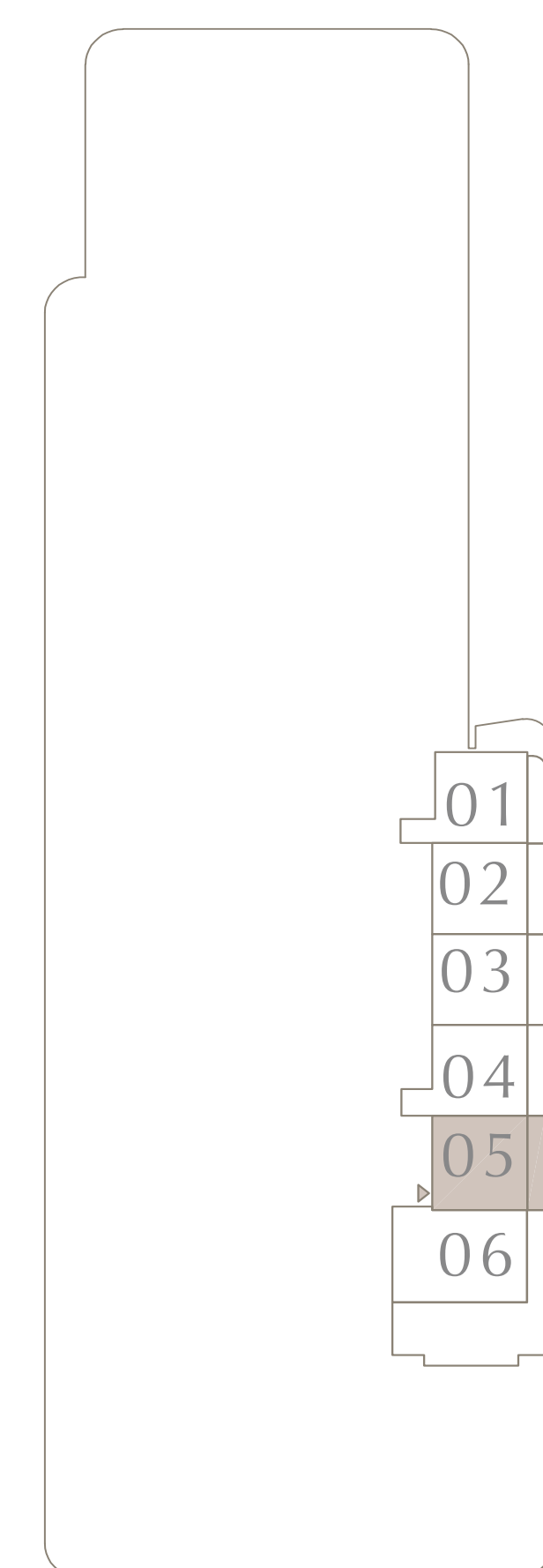
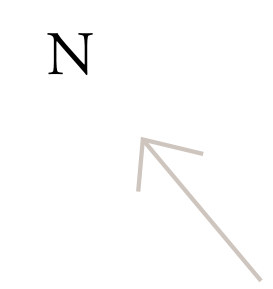

KEY SECTION

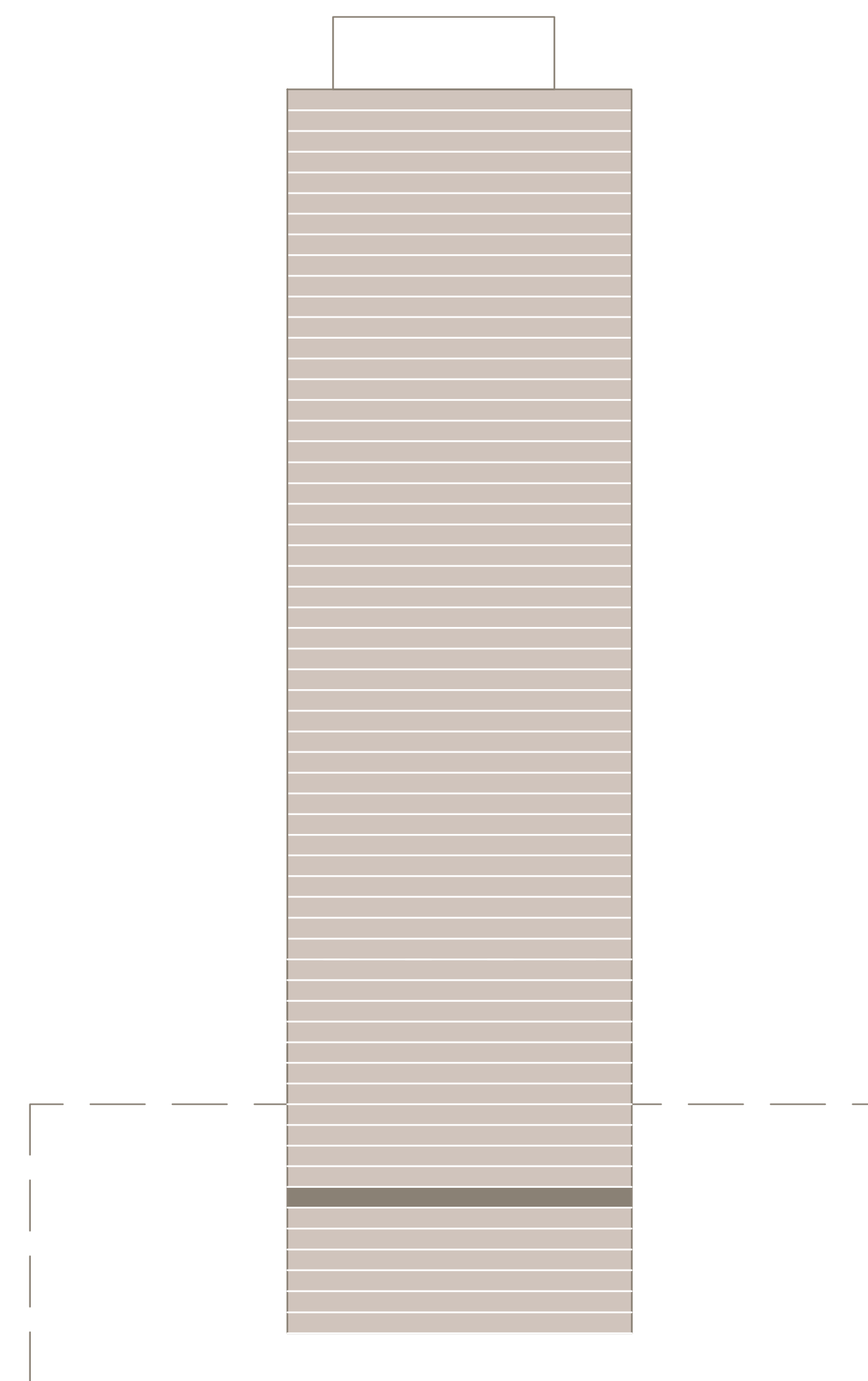

Disclaimer : All dimensions are in imperial and metric, and measured from finish to finish excluding construction tolerances. 2. All materials, dimensions, and drawings are approximate only. 3. Information is subject to change without notice, at developer's absolute discretion. 4. Actual area may vary from the stated area. 5. Drawings not to scale. 6. All images used are for illustrative purposes only and do not represent the actual size, features, specifications, fittings, and furnishings. 7. The developer reserves the right to make revisions / alterations, at its absolute discretion, without any liability whatsoever.



# ADDRESS RESIDENCES THE BAY

## 2 BEDROOM TYPE A 9

LEVEL 07 | UNIT 06

SUITE AREA	1046.58 SQ.FT.	97.23 SQ.M.
BALCONY AREA	918.81 SQ.FT.	85.36 SQ.M.
TOTAL AREA	1965.39 SQ.FT.	182.59 SQ.M.

KEY PLAN LEVEL

07

KEY SECTION

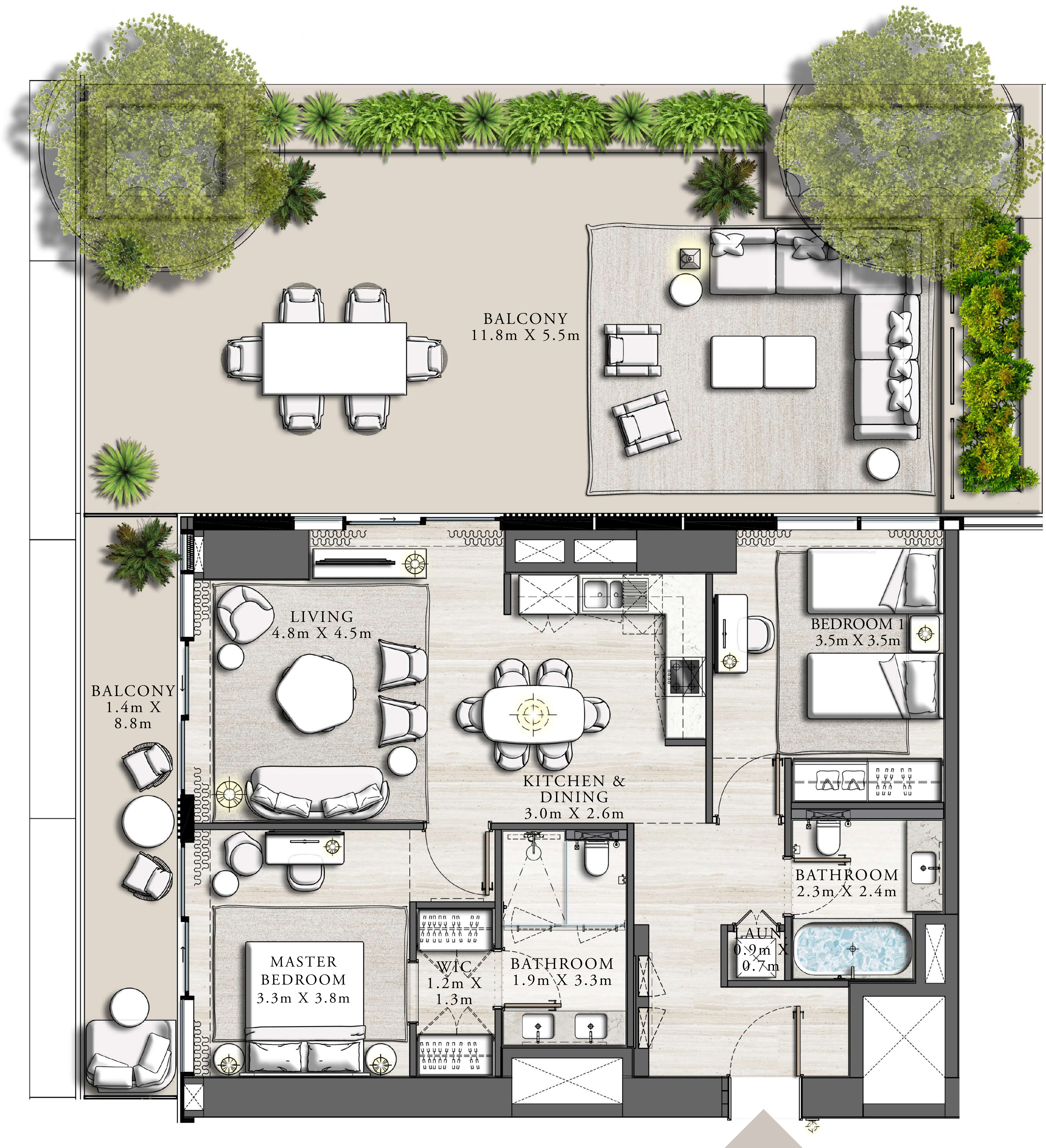
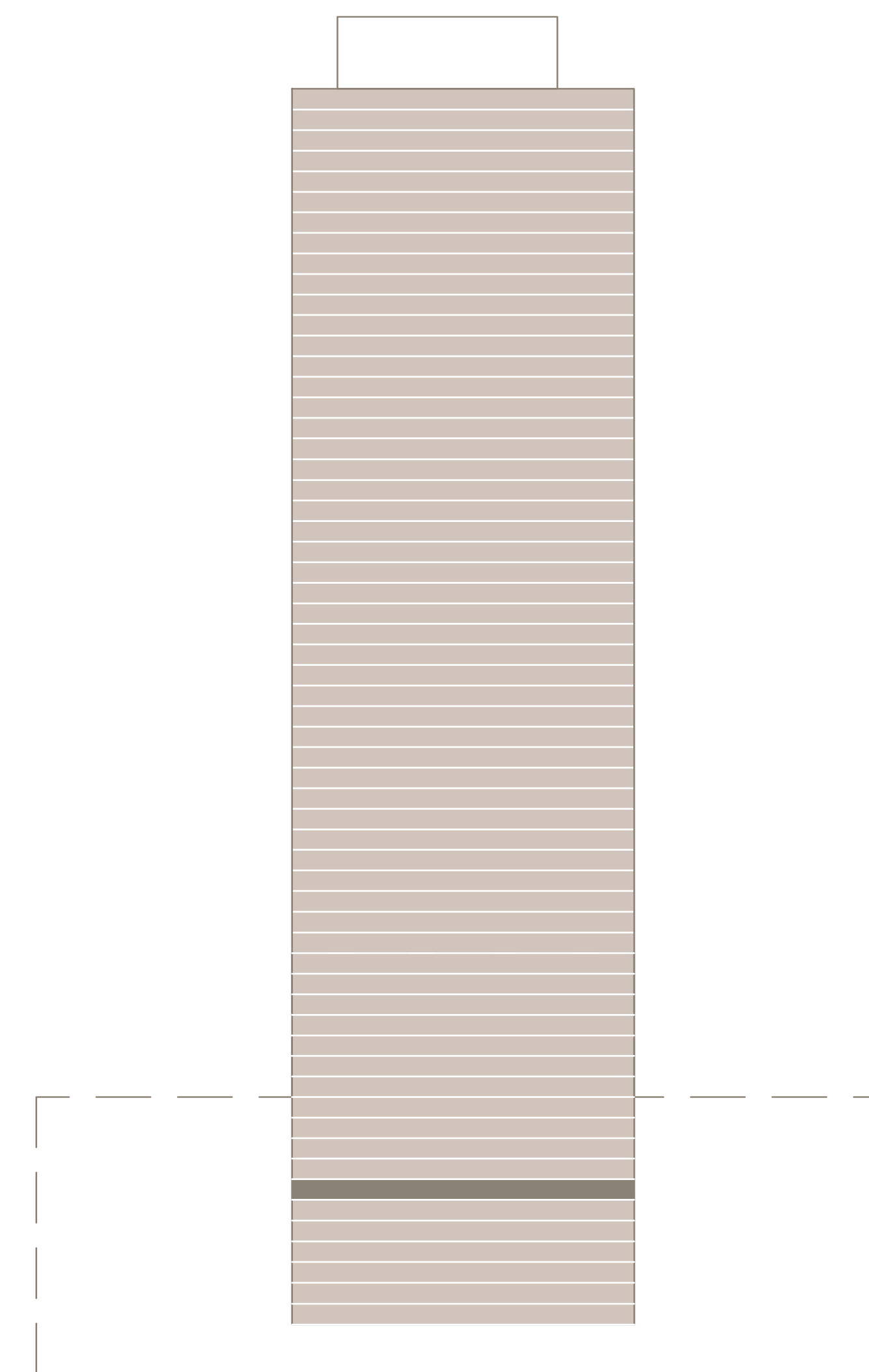
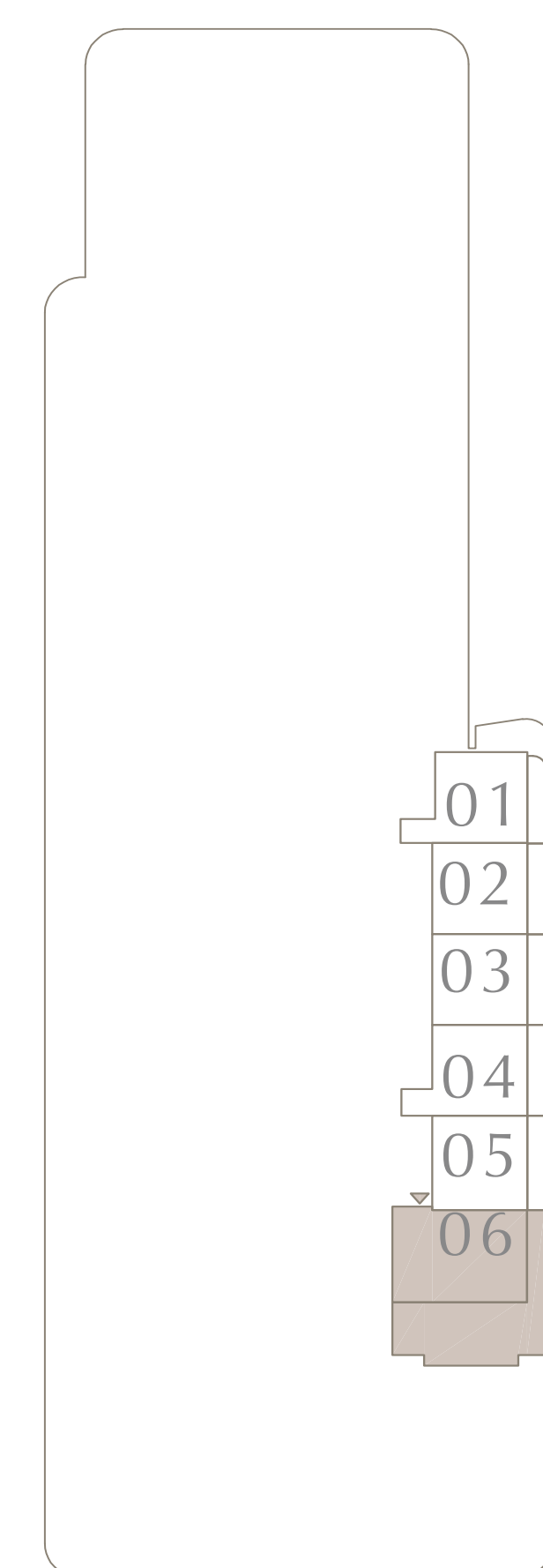
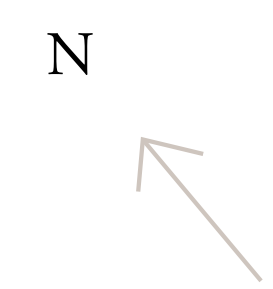

Disclaimer : All dimensions are in imperial and metric, and measured from finish to finish excluding construction tolerances. 2. All materials, dimensions, and drawings are approximate only. 3. Information is subject to change without notice, at developer's absolute discretion. 4. Actual area may vary from the stated area. 5. Drawings not to scale. 6. All images used are for illustrative purposes only and do not represent the actual size, features, specifications, fittings, and furnishings. 7. The developer reserves the right to make revisions / alterations, at its absolute discretion, without any liability whatsoever.



# ADDRESS RESIDENCES THE BAY

## 1 BEDROOM TYPE A 9

LEVELS 08-10 | UNIT 01

SUITE AREA	790.39 SQ.FT.	73.43 SQ.M.
BALCONY AREA	131.64 SQ.FT.	12.23 SQ.M.
TOTAL AREA	922.03 SQ.FT.	85.66 SQ.M.

KEY PLAN LEVEL  
08-10

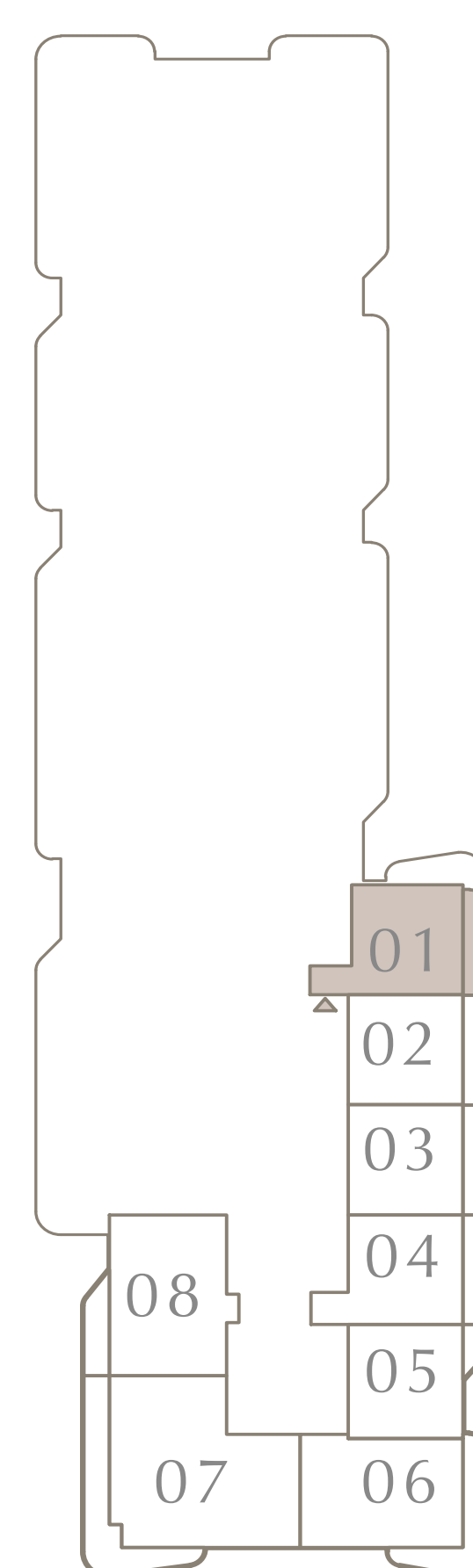
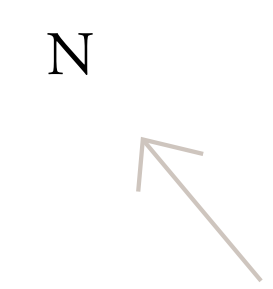

KEY SECTION

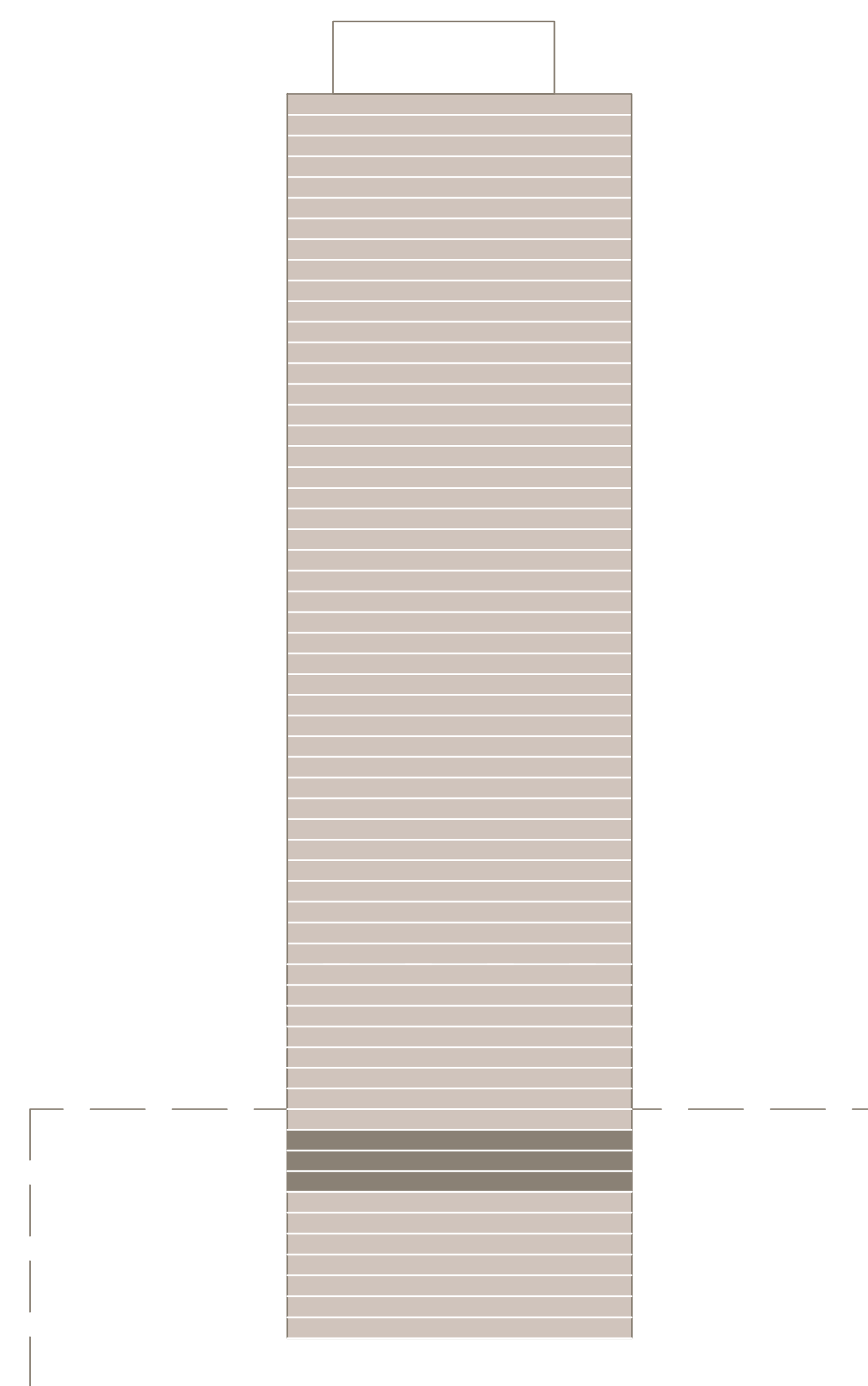

Disclaimer : All dimensions are in imperial and metric, and measured from finish to finish excluding construction tolerances. 2. All materials, dimensions, and drawings are approximate only. 3. Information is subject to change without notice, at developer's absolute discretion. 4. Actual area may vary from the stated area. 5. Drawings not to scale. 6. All images used are for illustrative purposes only and do not represent the actual size, features, specifications, fittings, and furnishings. 7. The developer reserves the right to make revisions / alterations, at its absolute discretion, without any liability whatsoever.



# ADDRESS RESIDENCES THE BAY

## 1 BEDROOM TYPE A 4

LEVELS 08-15 |

UNIT 02

SUITE AREA	698.36 SQ.FT.	64.88 SQ.M.
BALCONY AREA	142.08 SQ.FT.	13.20 SQ.M.
TOTAL AREA	840.44 SQ.FT.	78.08 SQ.M.

KEY PLAN LEVEL

08-15

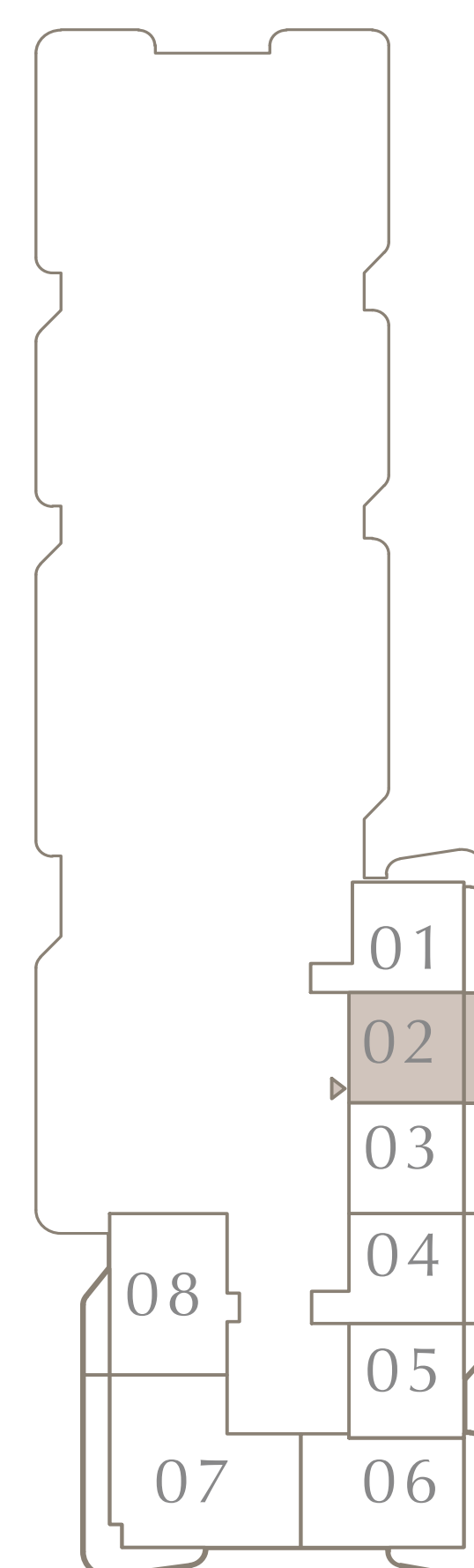
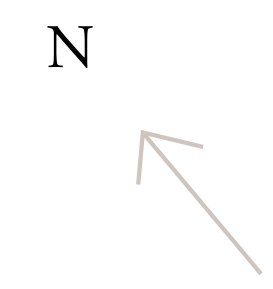

KEY SECTION

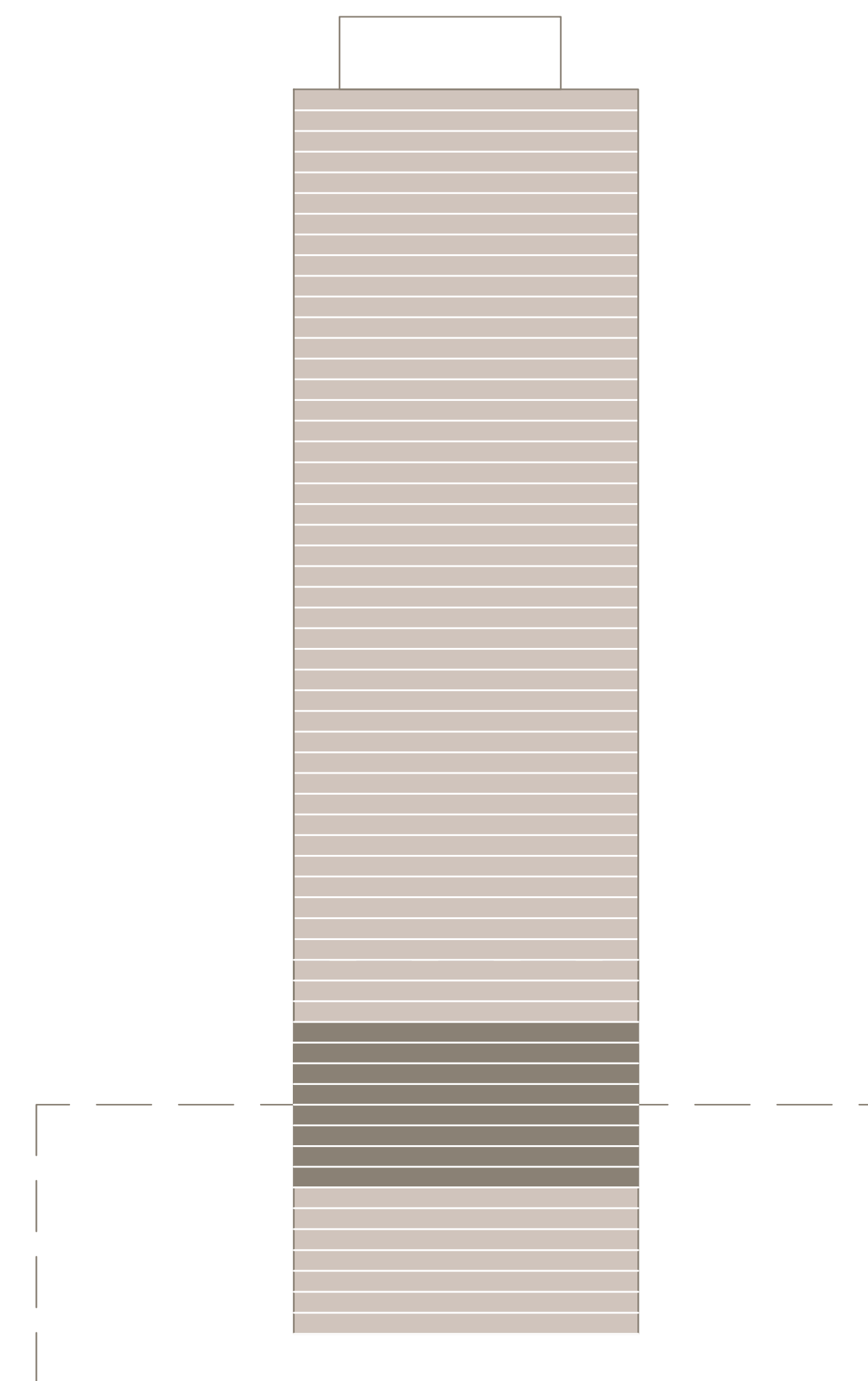

Disclaimer : All dimensions are in imperial and metric, and measured from finish to finish excluding construction tolerances. 2. All materials, dimensions, and drawings are approximate only. 3. Information is subject to change without notice, at developer's absolute discretion. 4. Actual area may vary from the stated area. 5. Drawings not to scale. 6. All images used are for illustrative purposes only and do not represent the actual size, features, specifications, fittings, and furnishings. 7. The developer reserves the right to make revisions / alterations, at its absolute discretion, without any liability whatsoever.





# ADDRESS RESIDENCES THE BAY

## 1 BEDROOM TYPE A 4

LEVELS 08-15 | UNIT 03

SUITE AREA	702.99 SQ.FT.	65.31 SQ.M.
BALCONY AREA	141.98 SQ.FT.	13.19 SQ.M.
TOTAL AREA	844.97 SQ.FT.	78.50 SQ.M.

KEY PLAN LEVEL

08-15

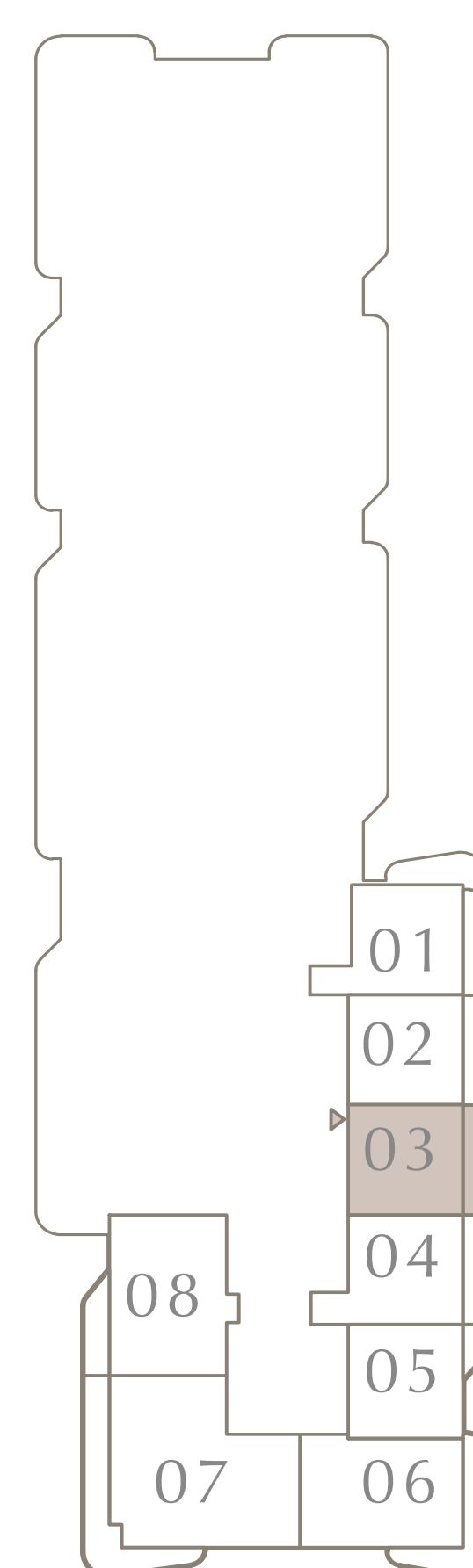
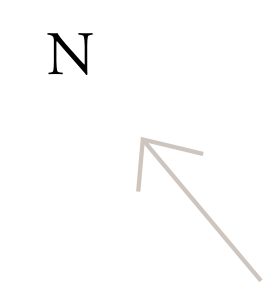

KEY SECTION

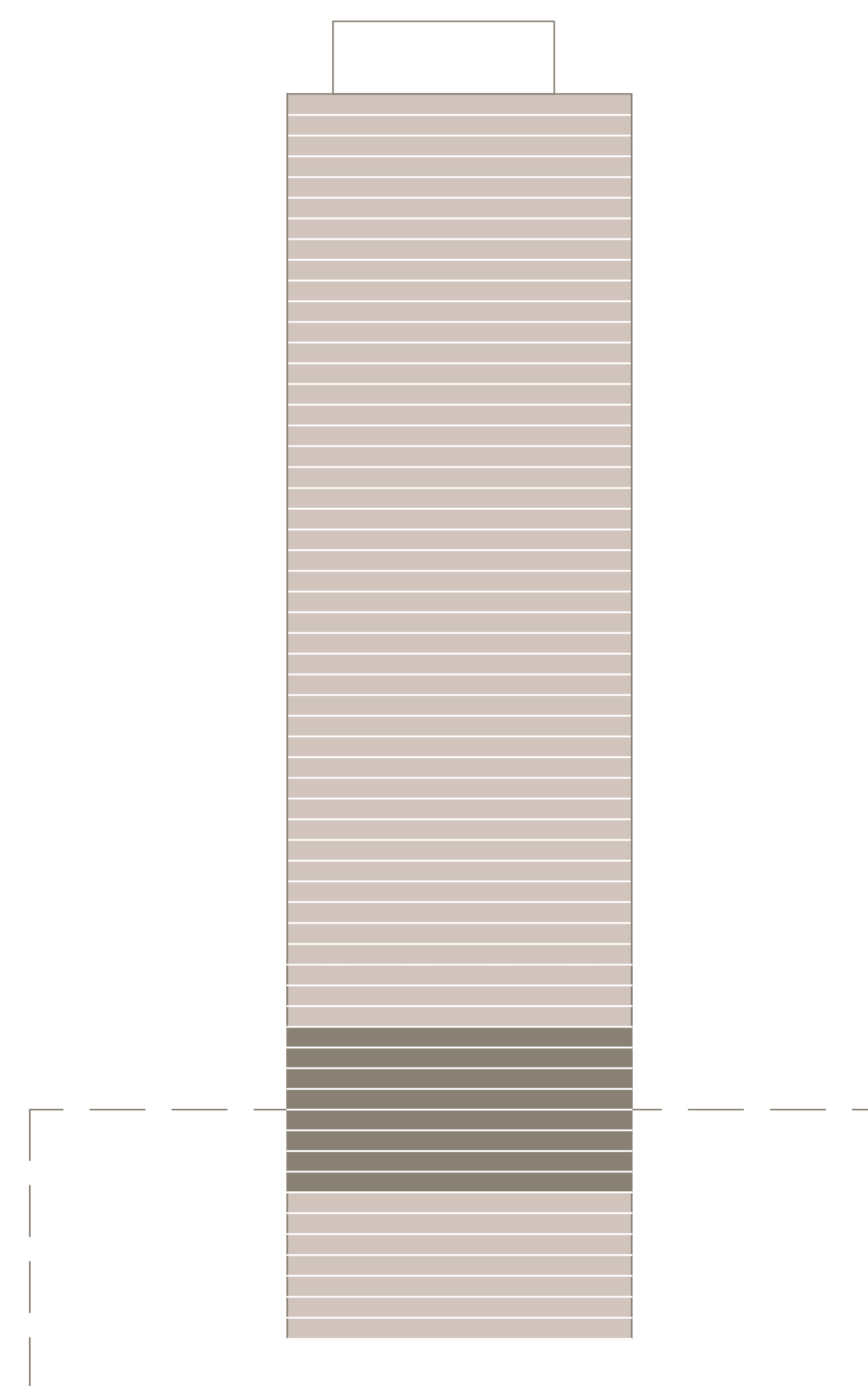

Disclaimer : All dimensions are in imperial and metric, and measured from finish to finish excluding construction tolerances. 2. All materials, dimensions, and drawings are approximate only. 3. Information is subject to change without notice, at developer's absolute discretion. 4. Actual area may vary from the stated area. 5. Drawings not to scale. 6. All images used are for illustrative purposes only and do not represent the actual size, features, specifications, fittings, and furnishings. 7. The developer reserves the right to make revisions / alterations, at its absolute discretion, without any liability whatsoever.



# ADDRESS RESIDENCES THE BAY

## 1 BEDROOM TYPE A 7

LEVELS 08-15 | UNIT 04

SUITE AREA	766.28 SQ.FT.	71.19 SQ.M.
BALCONY AREA	141.98 SQ.FT.	13.19 SQ.M.
TOTAL AREA	908.26 SQ.FT.	84.38 SQ.M.

KEY PLAN LEVEL

08-15

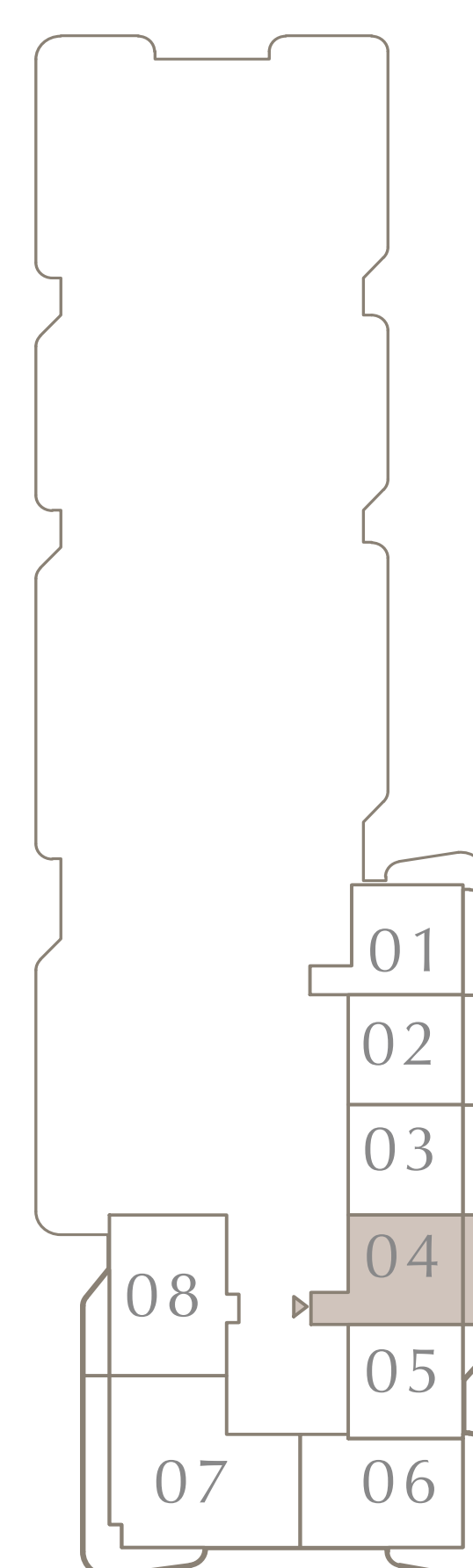
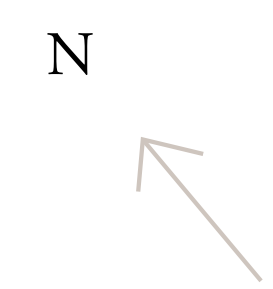

KEY SECTION

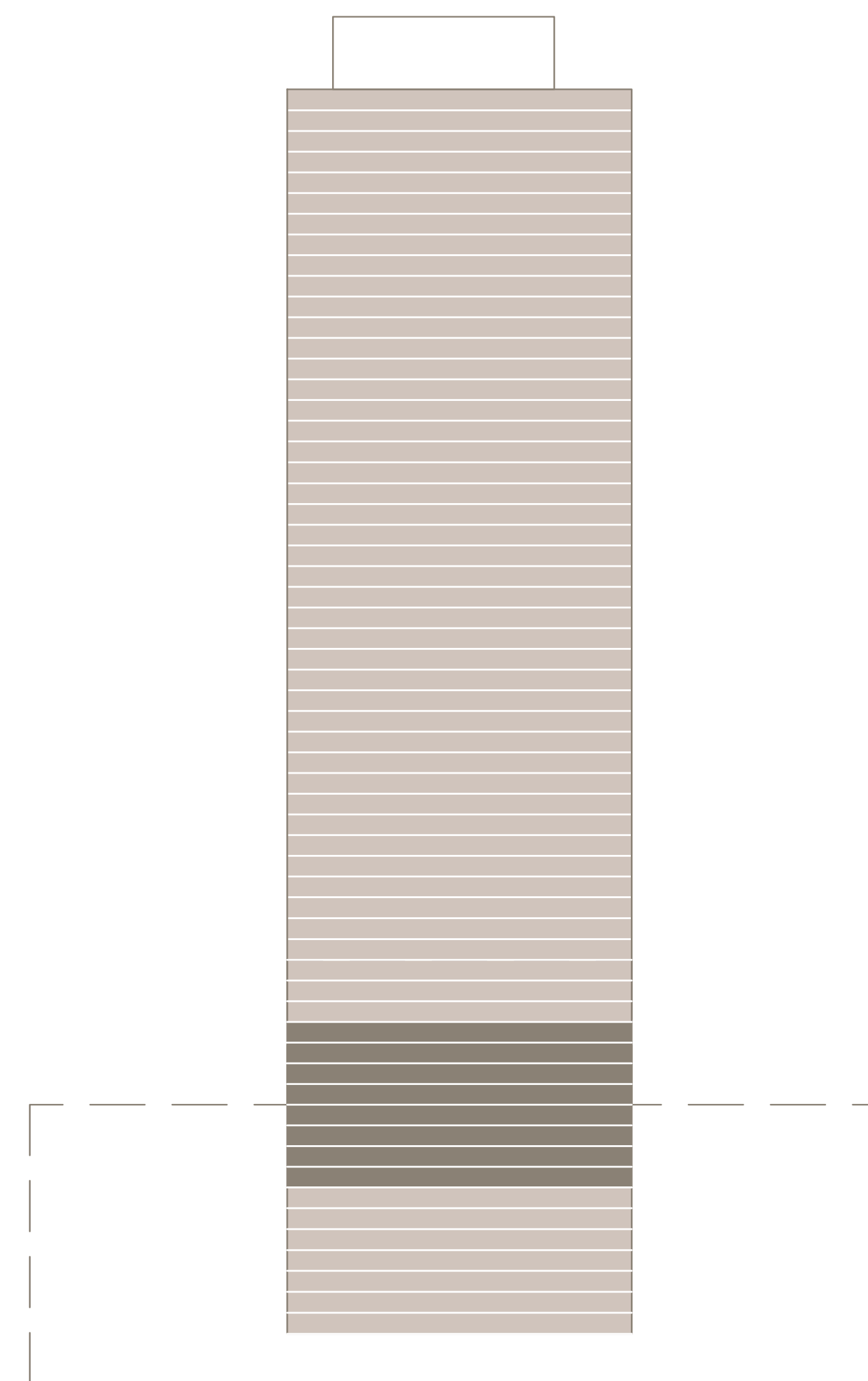

Disclaimer : All dimensions are in imperial and metric, and measured from finish to finish excluding construction tolerances. 2. All materials, dimensions, and drawings are approximate only. 3. Information is subject to change without notice, at developer's absolute discretion. 4. Actual area may vary from the stated area. 5. Drawings not to scale. 6. All images used are for illustrative purposes only and do not represent the actual size, features, specifications, fittings, and furnishings. 7. The developer reserves the right to make revisions / alterations, at its absolute discretion, without any liability whatsoever.



# ADDRESS RESIDENCES THE BAY

## 1 BEDROOM TYPE A 5

LEVELS 08-15 | UNIT 05

SUITE AREA	699.22 SQ.FT.	64.96 SQ.M.
BALCONY AREA	56.73 SQ.FT.	5.27 SQ.M.
TOTAL AREA	755.95 SQ.FT.	70.23 SQ.M.

KEY PLAN LEVEL

08-15

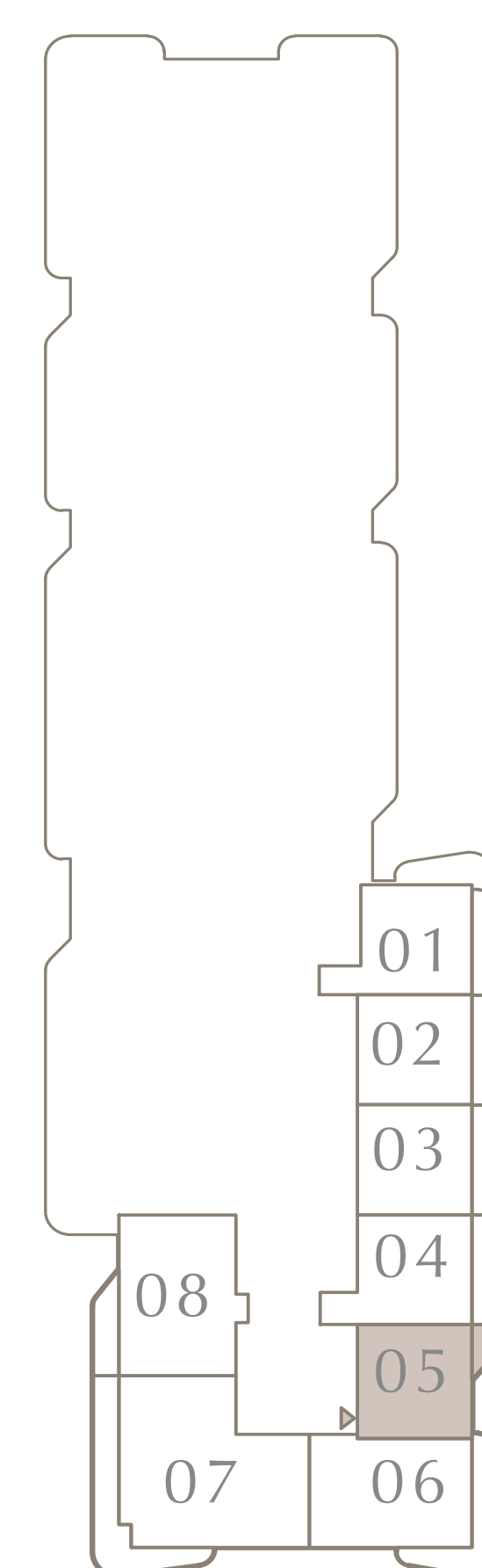
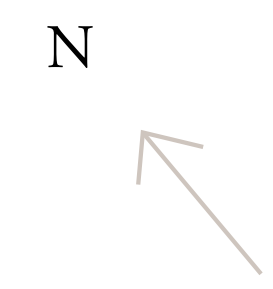

KEY SECTION

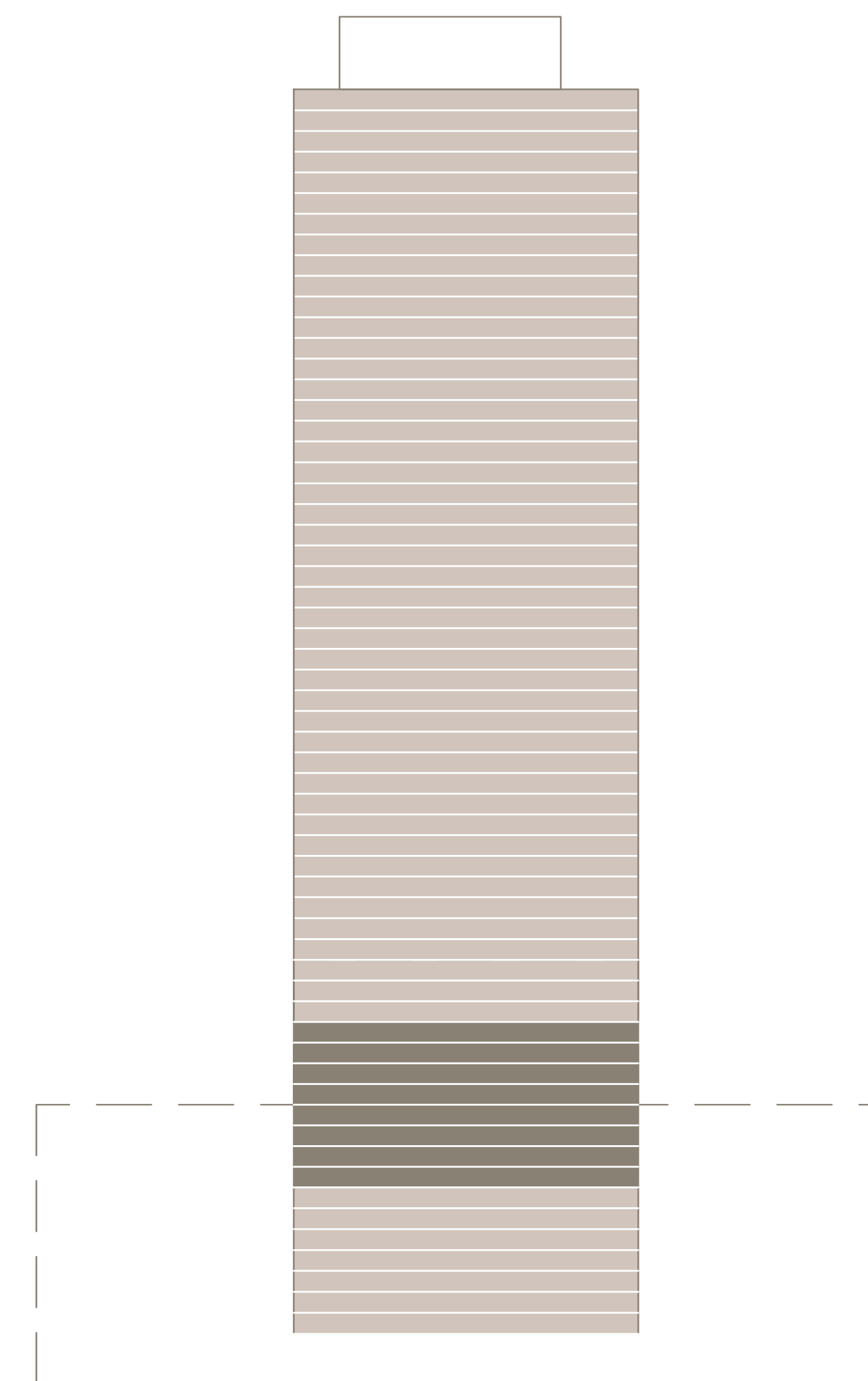

Disclaimer : All dimensions are in imperial and metric, and measured from finish to finish excluding construction tolerances. 2. All materials, dimensions, and drawings are approximate only. 3. Information is subject to change without notice, at developer's absolute discretion. 4. Actual area may vary from the stated area. 5. Drawings not to scale. 6. All images used are for illustrative purposes only and do not represent the actual size, features, specifications, fittings, and furnishings. 7. The developer reserves the right to make revisions / alterations, at its absolute discretion, without any liability whatsoever.



# ADDRESS RESIDENCES THE BAY

## 2 BEDROOM TYPE A 8

LEVELS 08-15 |

UNIT 06

SUITE AREA	1051.53 SQ.FT.	97.69 SQ.M.
BALCONY AREA	263.93 SQ.FT.	24.52 SQ.M.
TOTAL AREA	1315.46 SQ.FT.	122.21 SQ.M.

KEY PLAN LEVEL

08-15

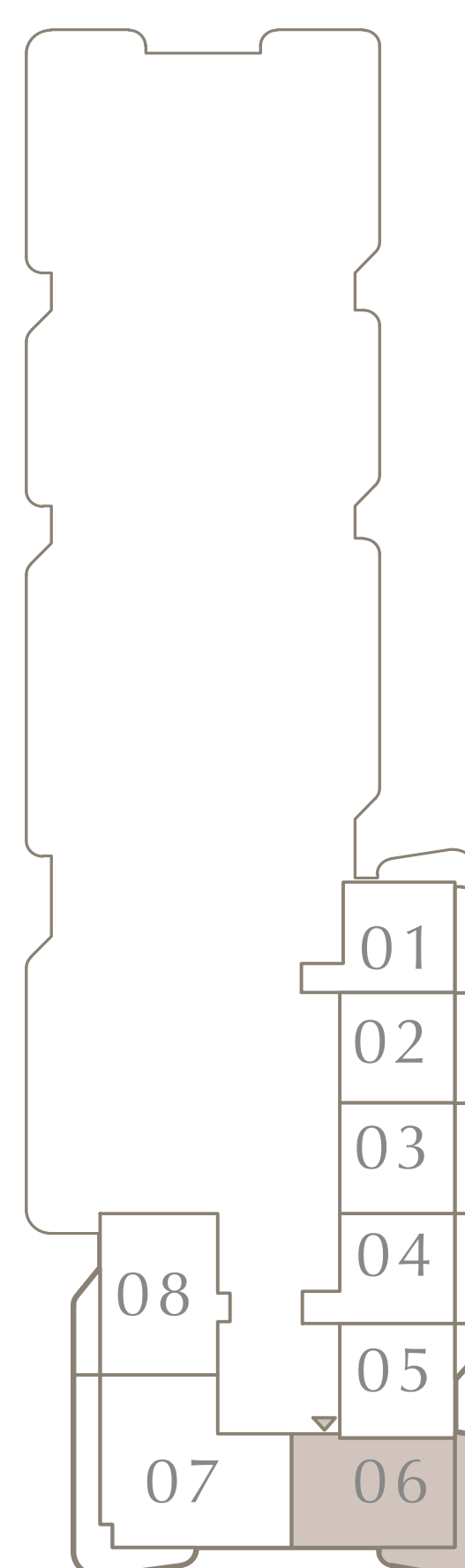
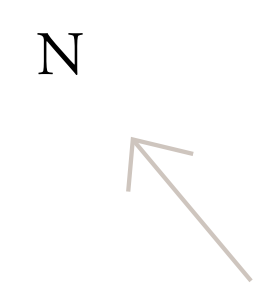

KEY SECTION

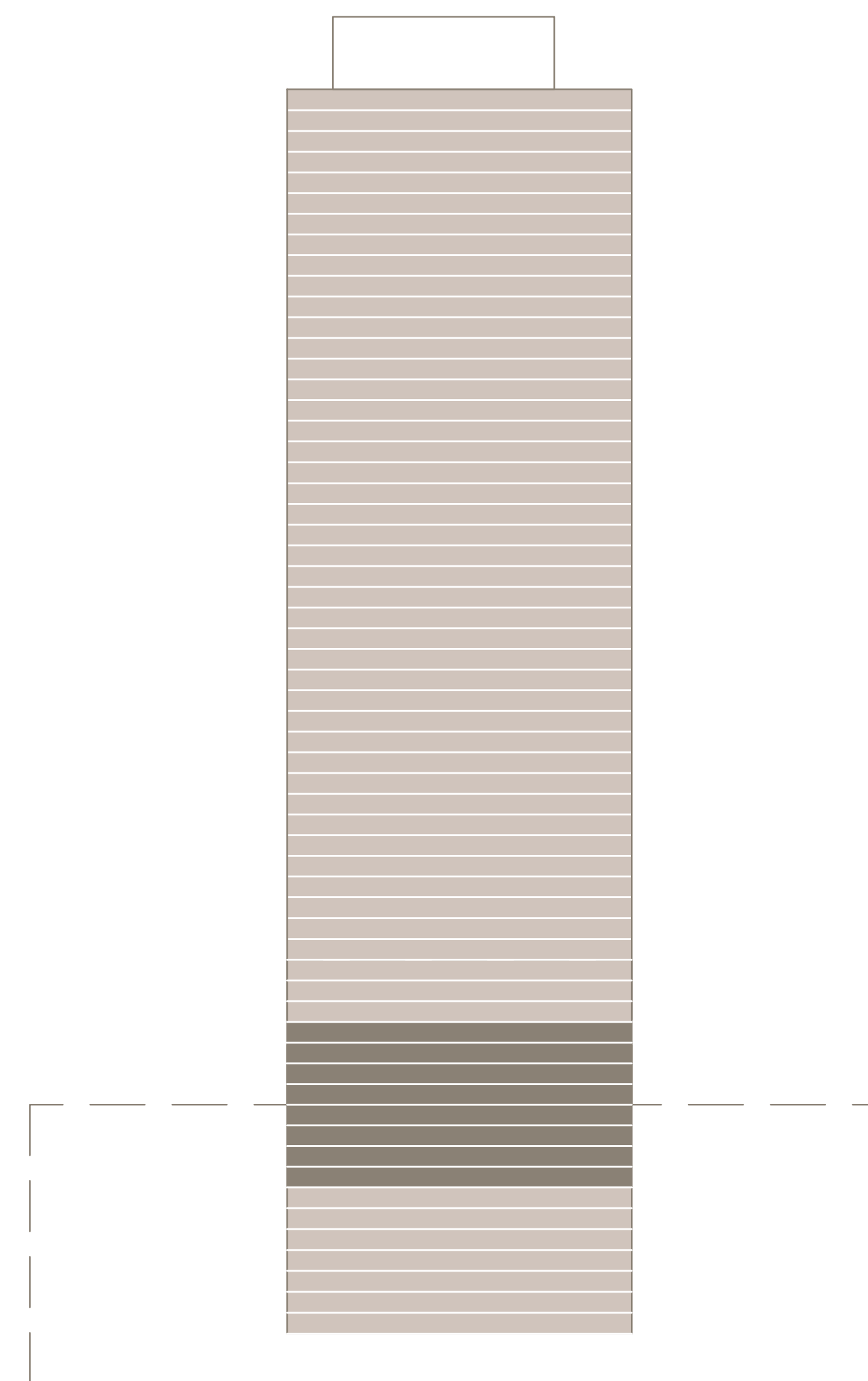

Disclaimer : All dimensions are in imperial and metric, and measured from finish to finish excluding construction tolerances. 2. All materials, dimensions, and drawings are approximate only. 3. Information is subject to change without notice, at developer's absolute discretion. 4. Actual area may vary from the stated area. 5. Drawings not to scale. 6. All images used are for illustrative purposes only and do not represent the actual size, features, specifications, fittings, and furnishings. 7. The developer reserves the right to make revisions / alterations, at its absolute discretion, without any liability whatsoever.



# ADDRESS RESIDENCES THE BAY

## 3 BEDROOM TYPE A 3

LEVELS 08-15 | UNIT 07

SUITE AREA	1636.22 SQ.FT.	152.01 SQ.M.
BALCONY AREA	432.28 SQ.FT.	40.16 SQ.M.
TOTAL AREA	2068.50 SQ.FT.	192.17 SQ.M.

KEY PLAN LEVEL

08-15

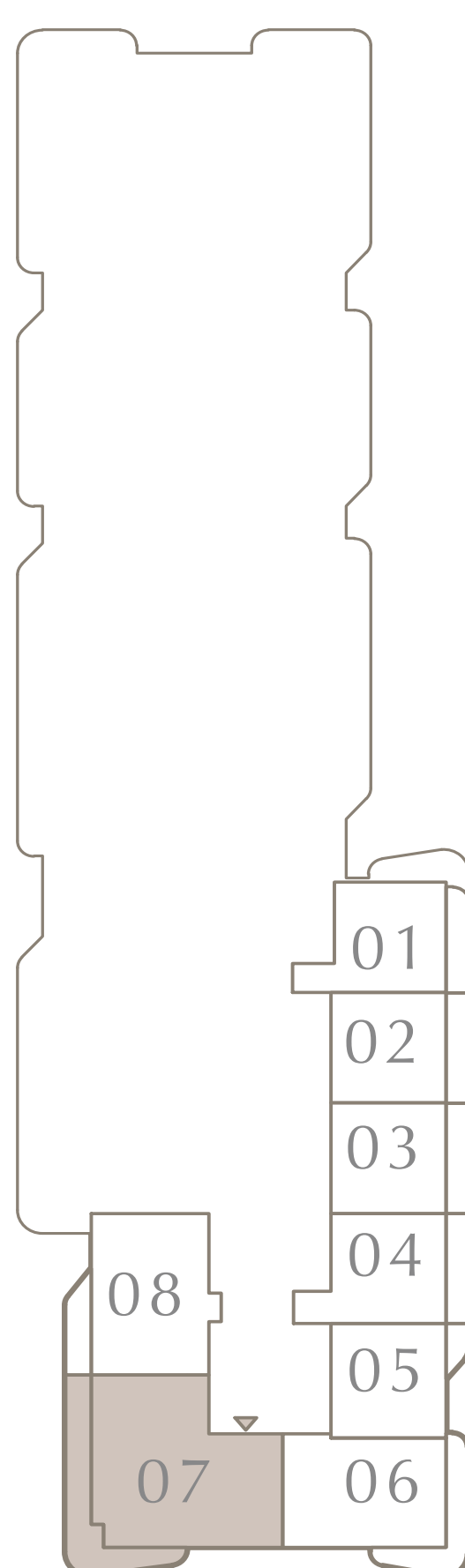
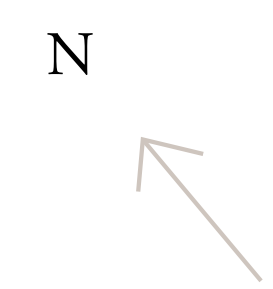

KEY SECTION

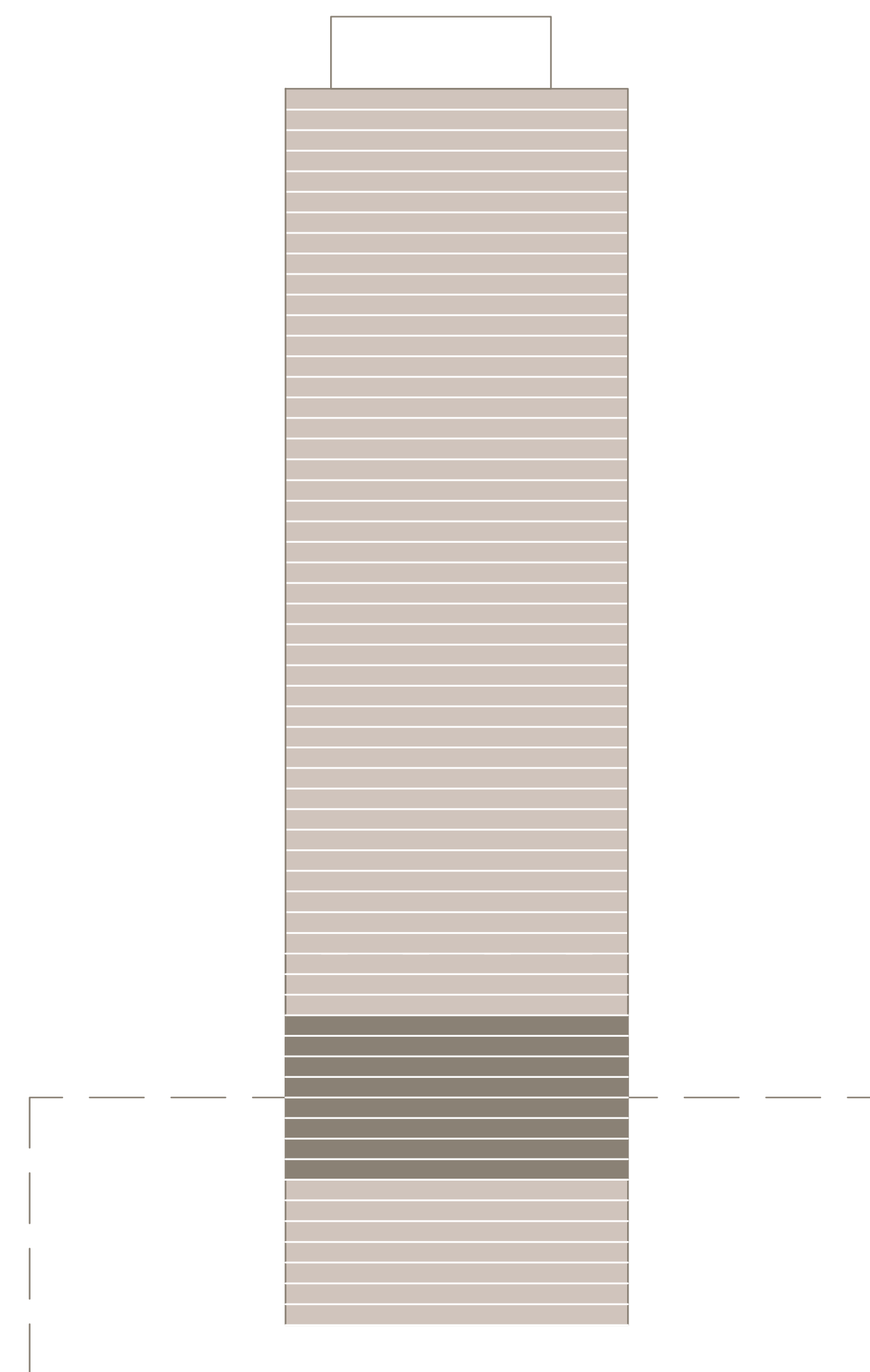

Disclaimer : All dimensions are in imperial and metric, and measured from finish to finish excluding construction tolerances. 2. All materials, dimensions, and drawings are approximate only. 3. Information is subject to change without notice, at developer's absolute discretion. 4. Actual area may vary from the stated area. 5. Drawings not to scale. 6. All images used are for illustrative purposes only and do not represent the actual size, features, specifications, fittings, and furnishings. 7. The developer reserves the right to make revisions / alterations, at its absolute discretion, without any liability whatsoever.



# ADDRESS RESIDENCES THE BAY

## 2 BEDROOM TYPE A 7

LEVELS 08-15 |

UNIT 08

SUITE AREA	1134.41 SQ.FT.	105.39 SQ.M.
BALCONY AREA	148.54 SQ.FT.	13.80 SQ.M.
TOTAL AREA	1282.95 SQ.FT.	119.19 SQ.M.

KEY PLAN LEVEL

08-15

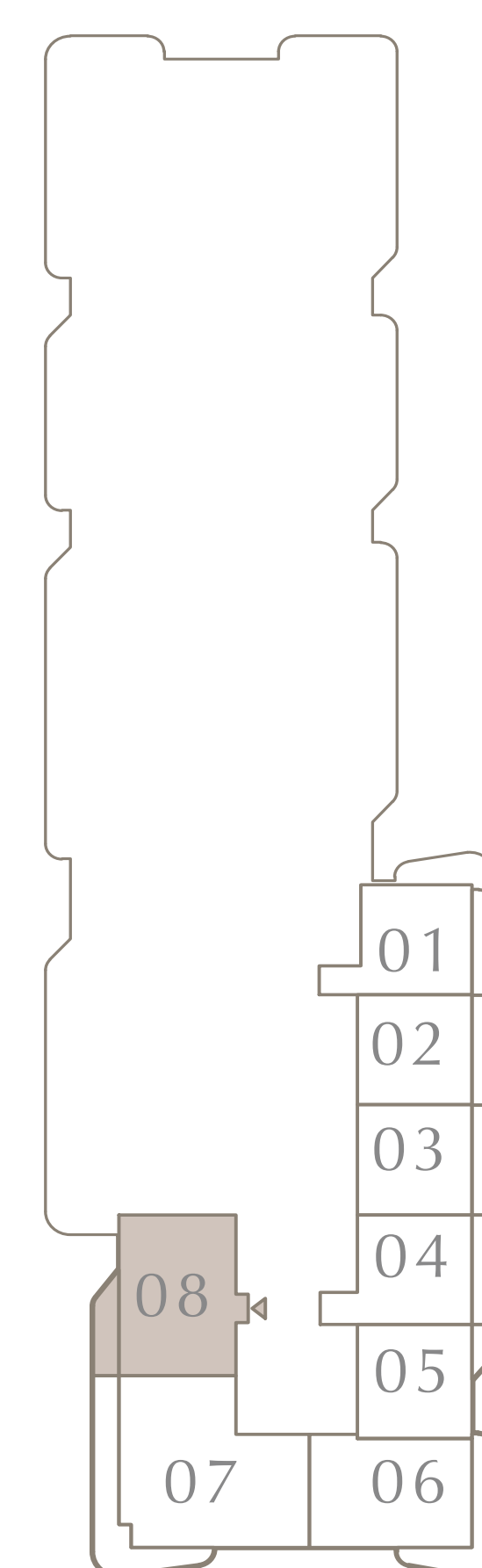
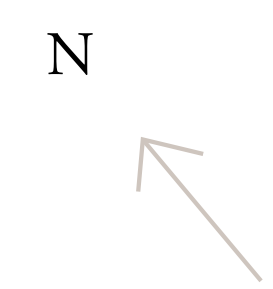

KEY SECTION

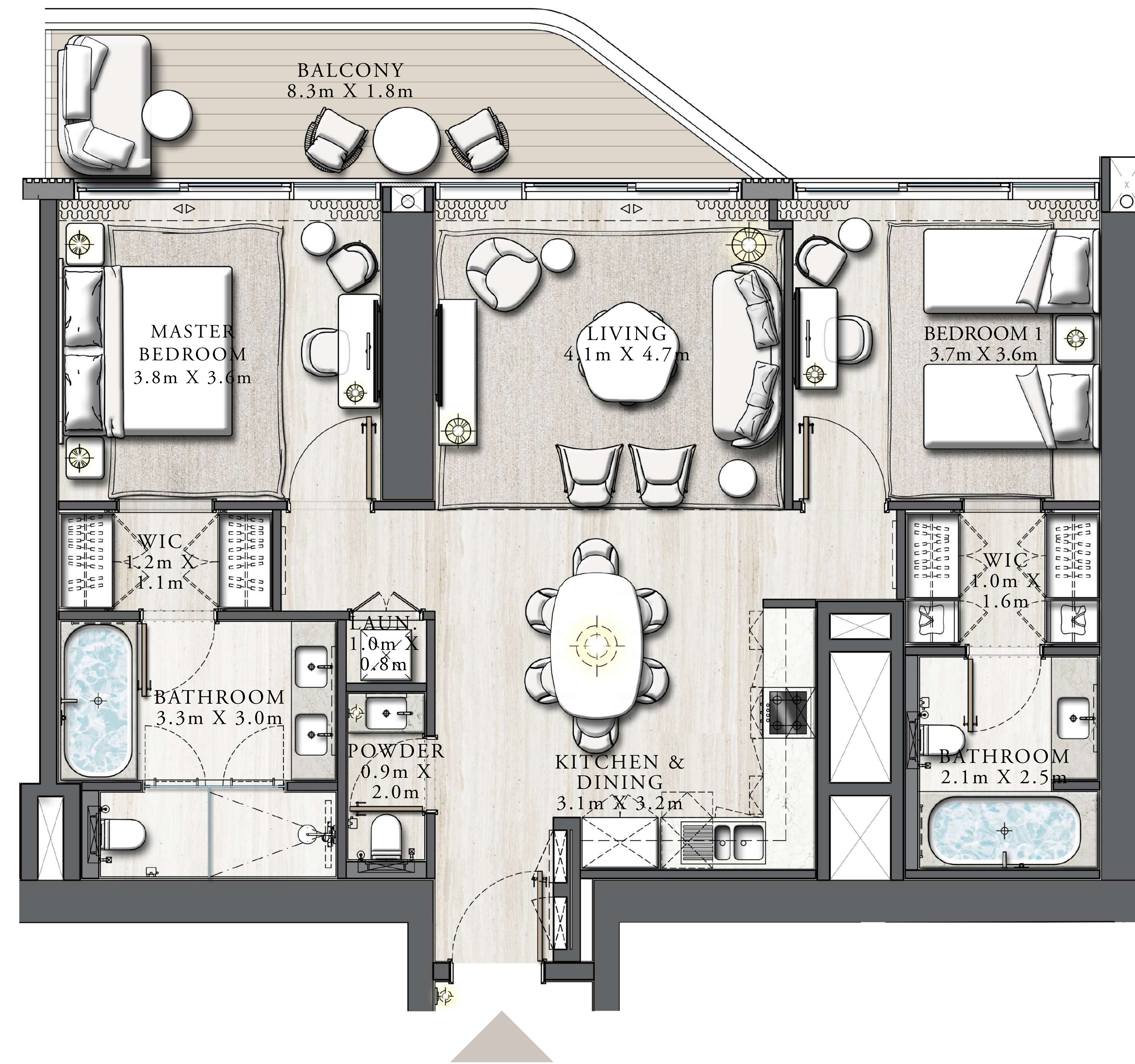
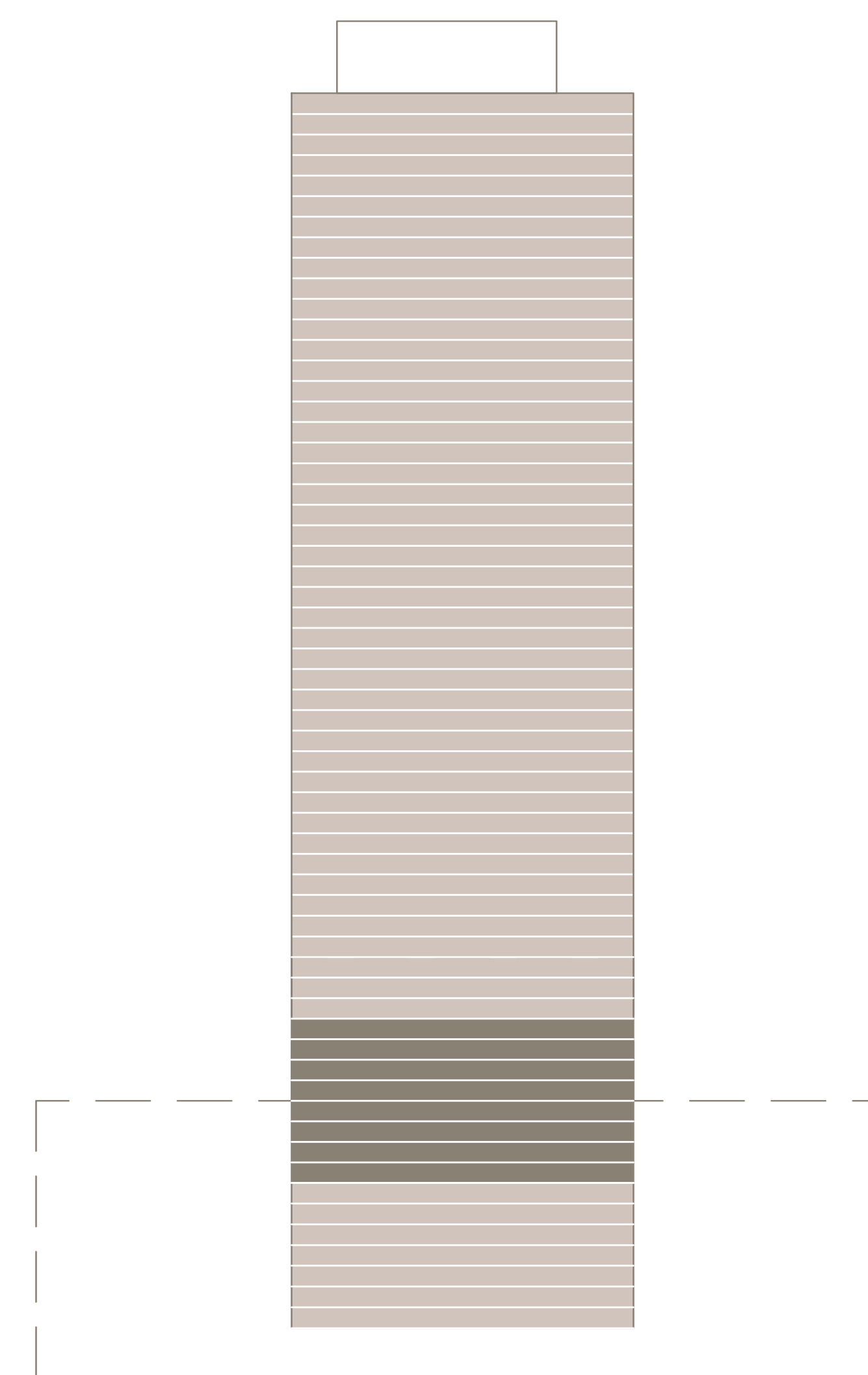

Disclaimer : All dimensions are in imperial and metric, and measured from finish to finish excluding construction tolerances. 2. All materials, dimensions, and drawings are approximate only. 3. Information is subject to change without notice, at developer's absolute discretion. 4. Actual area may vary from the stated area. 5. Drawings not to scale. 6. All images used are for illustrative purposes only and do not represent the actual size, features, specifications, fittings, and furnishings. 7. The developer reserves the right to make revisions / alterations, at its absolute discretion, without any liability whatsoever.



# ADDRESS RESIDENCES THE BAY

## 1 BEDROOM TYPE A 9

LEVELS 11-15 | UNIT 01

SUITE AREA	786.52 SQ.FT.	73.07 SQ.M.
BALCONY AREA	131.64 SQ.FT.	12.23 SQ.M.
TOTAL AREA	918.16 SQ.FT.	85.30 SQ.M.

KEY PLAN LEVEL  
11-15

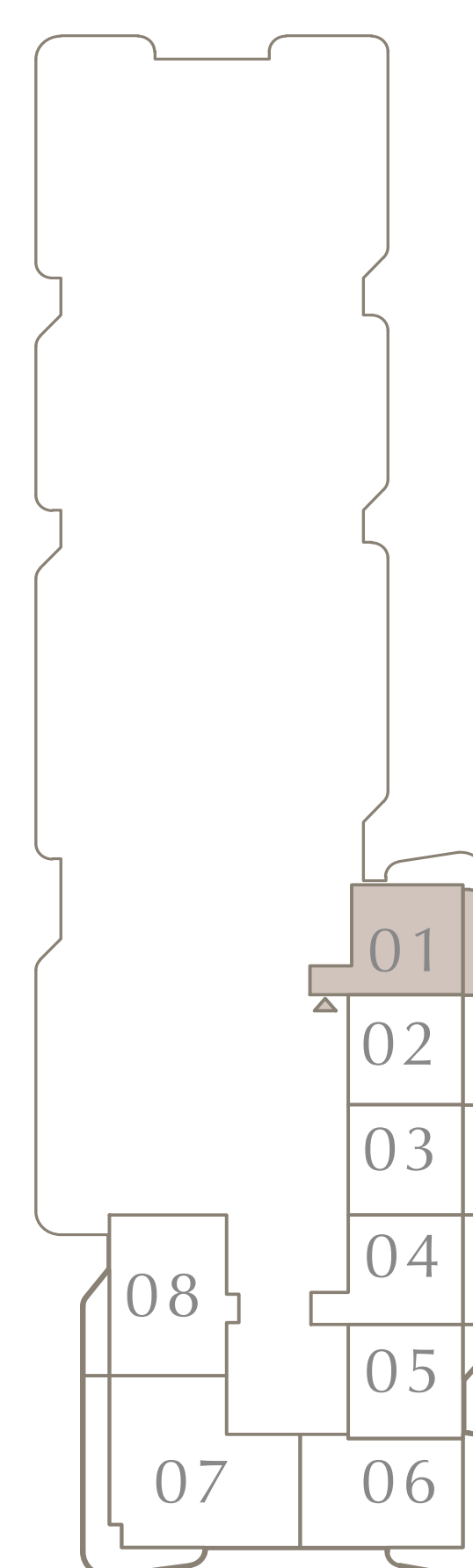

KEY SECTION

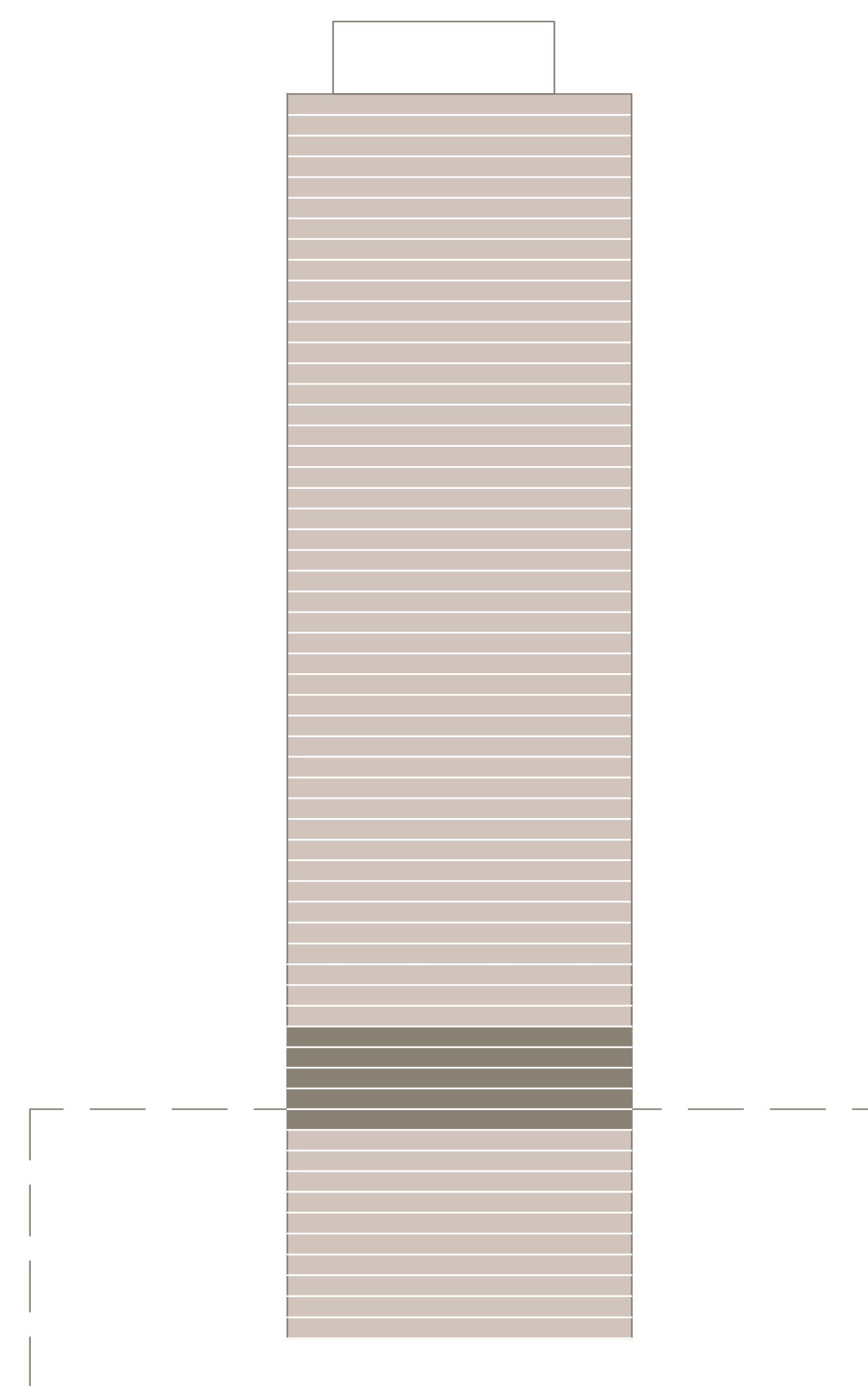

Disclaimer : All dimensions are in imperial and metric, and measured from finish to finish excluding construction tolerances. 2. All materials, dimensions, and drawings are approximate only. 3. Information is subject to change without notice, at developer's absolute discretion. 4. Actual area may vary from the stated area. 5. Drawings not to scale. 6. All images used are for illustrative purposes only and do not represent the actual size, features, specifications, fittings, and furnishings. 7. The developer reserves the right to make revisions / alterations, at its absolute discretion, without any liability whatsoever.



# ADDRESS RESIDENCES THE BAY

## 3 BEDROOM TYPE A 3

LEVEL 17 | UNIT 01

SUITE AREA	1634.07 SQ.FT.	151.81 SQ.M.
BALCONY AREA	334.97 SQ.FT.	31.12 SQ.M.
TOTAL AREA	1969.04 SQ.FT.	182.93 SQ.M.

KEY PLAN LEVEL

17

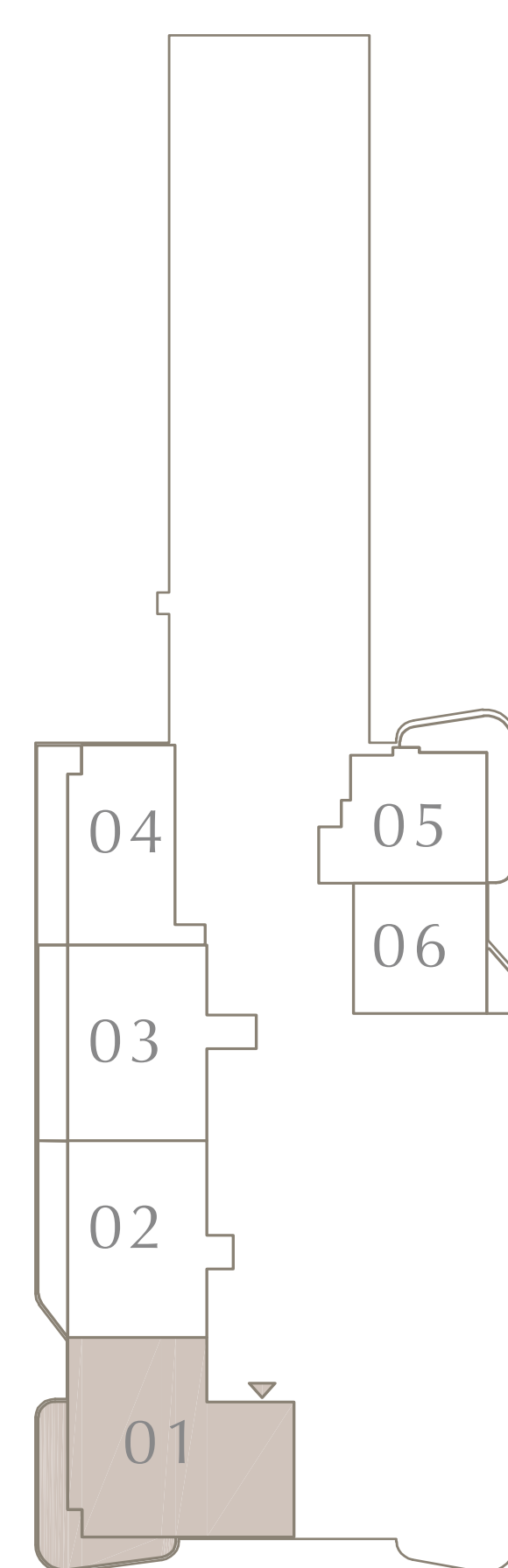
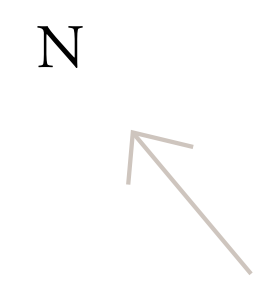

KEY SECTION

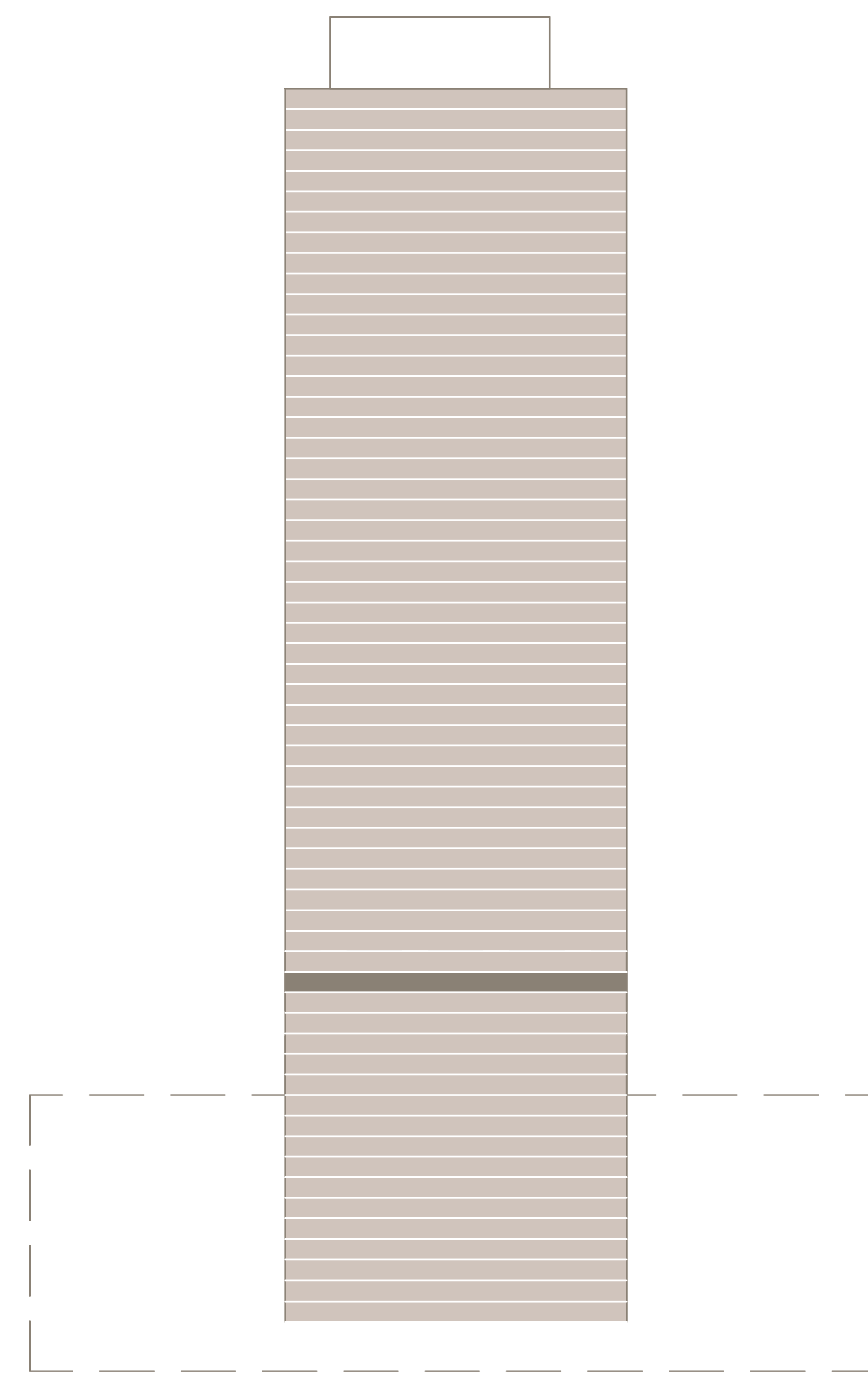

Disclaimer : All dimensions are in imperial and metric, and measured from finish to finish excluding construction tolerances. 2. All materials, dimensions, and drawings are approximate only. 3. Information is subject to change without notice, at developer's absolute discretion. 4. Actual area may vary from the stated area. 5. Drawings not to scale. 6. All images used are for illustrative purposes only and do not represent the actual size, features, specifications, fittings, and furnishings. 7. The developer reserves the right to make revisions / alterations, at its absolute discretion, without any liability whatsoever.





# ADDRESS RESIDENCES THE BAY

## 2 BEDROOM TYPE A 5

LEVEL 17 | UNIT 02

SUITE AREA	1155.40 SQ.FT.	107.34 SQ.M.
BALCONY AREA	227.23 SQ.FT.	21.11 SQ.M.
TOTAL AREA	1382.63 SQ.FT.	128.45 SQ.M.

KEY PLAN LEVEL

17

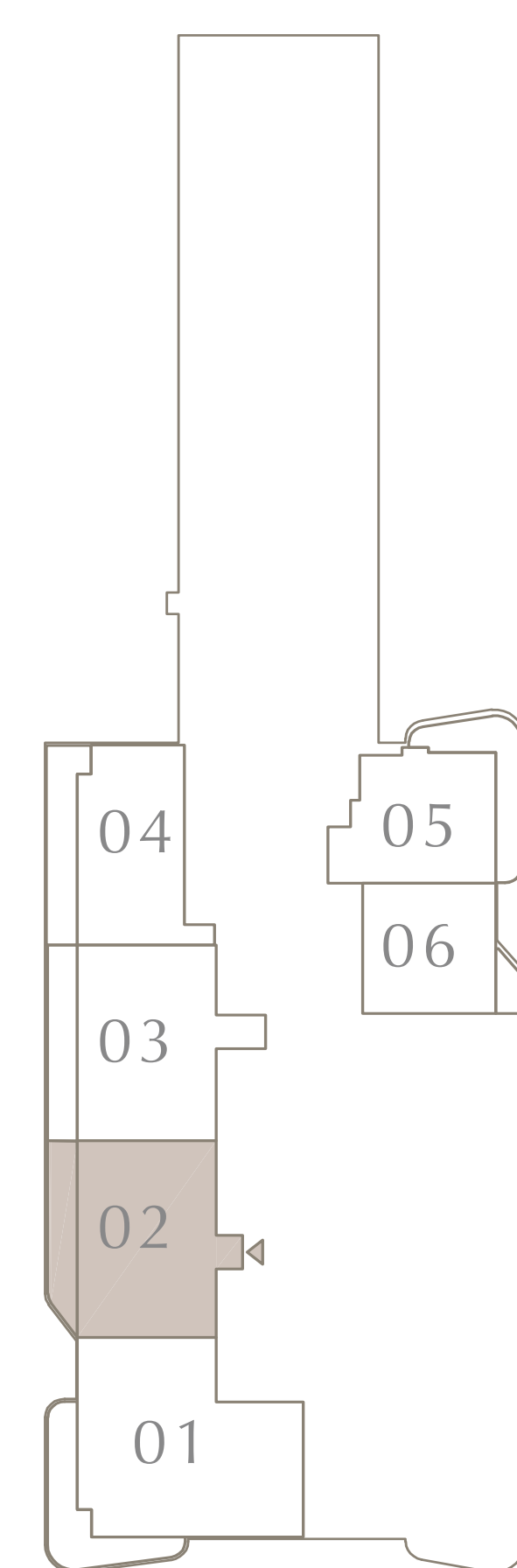
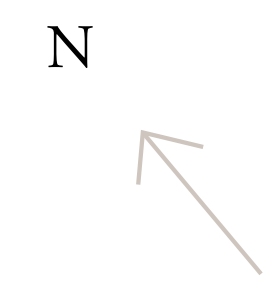

KEY SECTION

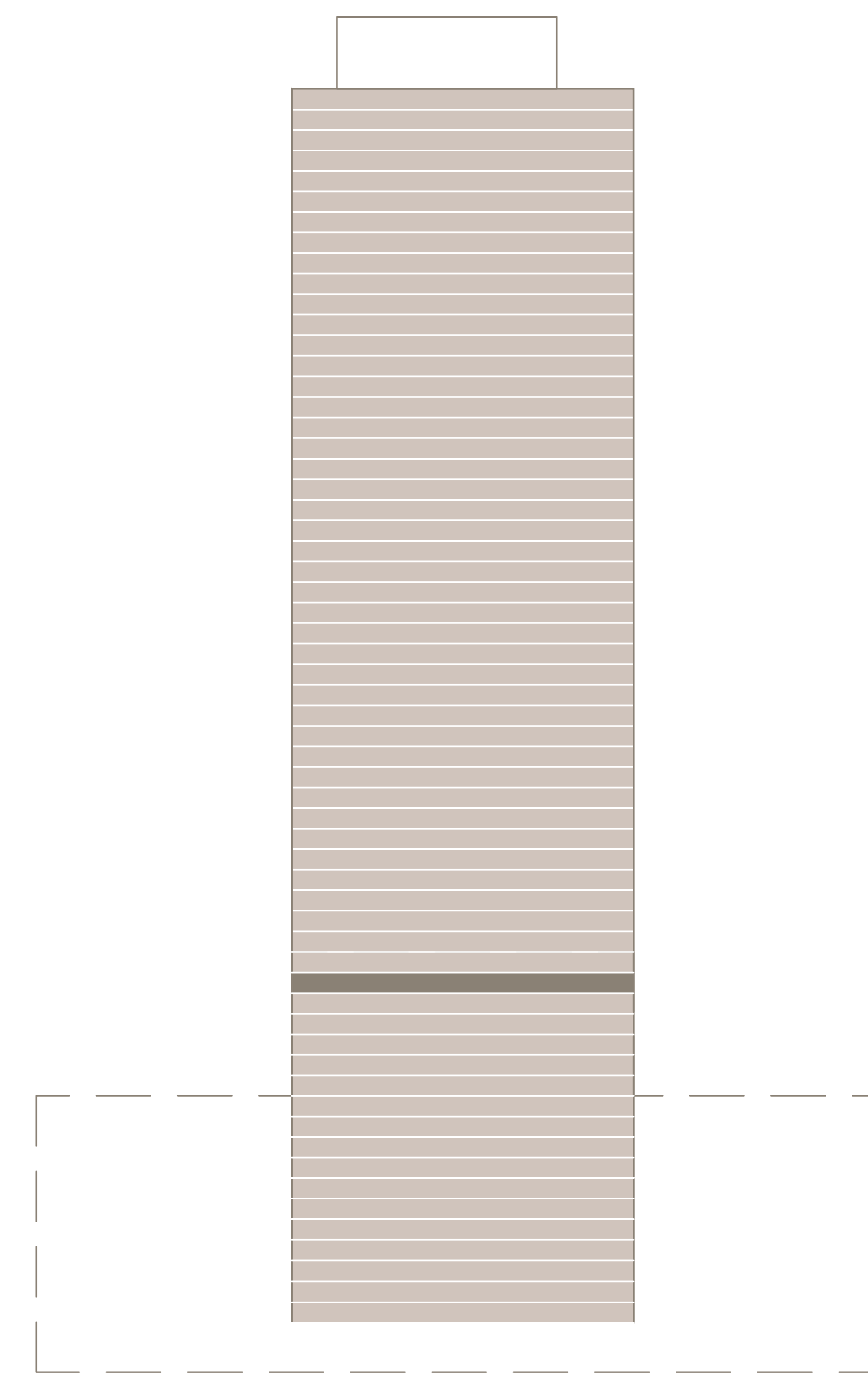

Disclaimer : All dimensions are in imperial and metric, and measured from finish to finish excluding construction tolerances. 2. All materials, dimensions, and drawings are approximate only. 3. Information is subject to change without notice, at developer's absolute discretion. 4. Actual area may vary from the stated area. 5. Drawings not to scale. 6. All images used are for illustrative purposes only and do not represent the actual size, features, specifications, fittings, and furnishings. 7. The developer reserves the right to make revisions / alterations, at its absolute discretion, without any liability whatsoever.



# ADDRESS RESIDENCES THE BAY

## 2 BEDROOM TYPE A 6

LEVEL 17 | UNIT 03

SUITE AREA	1188.87 SQ.FT.	110.45 SQ.M.
BALCONY AREA	251.34 SQ.FT.	23.35 SQ.M.
TOTAL AREA	1440.21 SQ.FT.	133.80 SQ.M.

KEY PLAN LEVEL

17

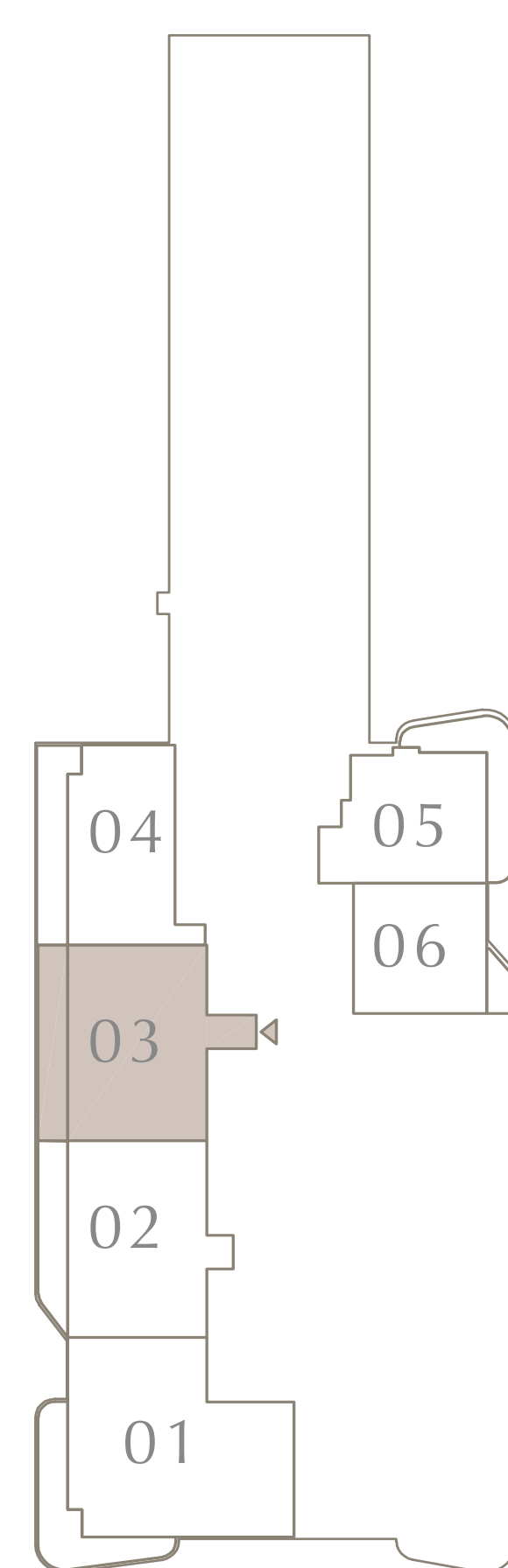
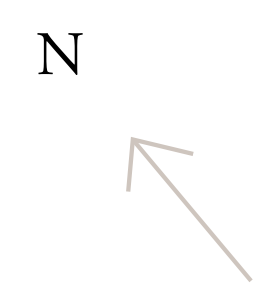

KEY SECTION

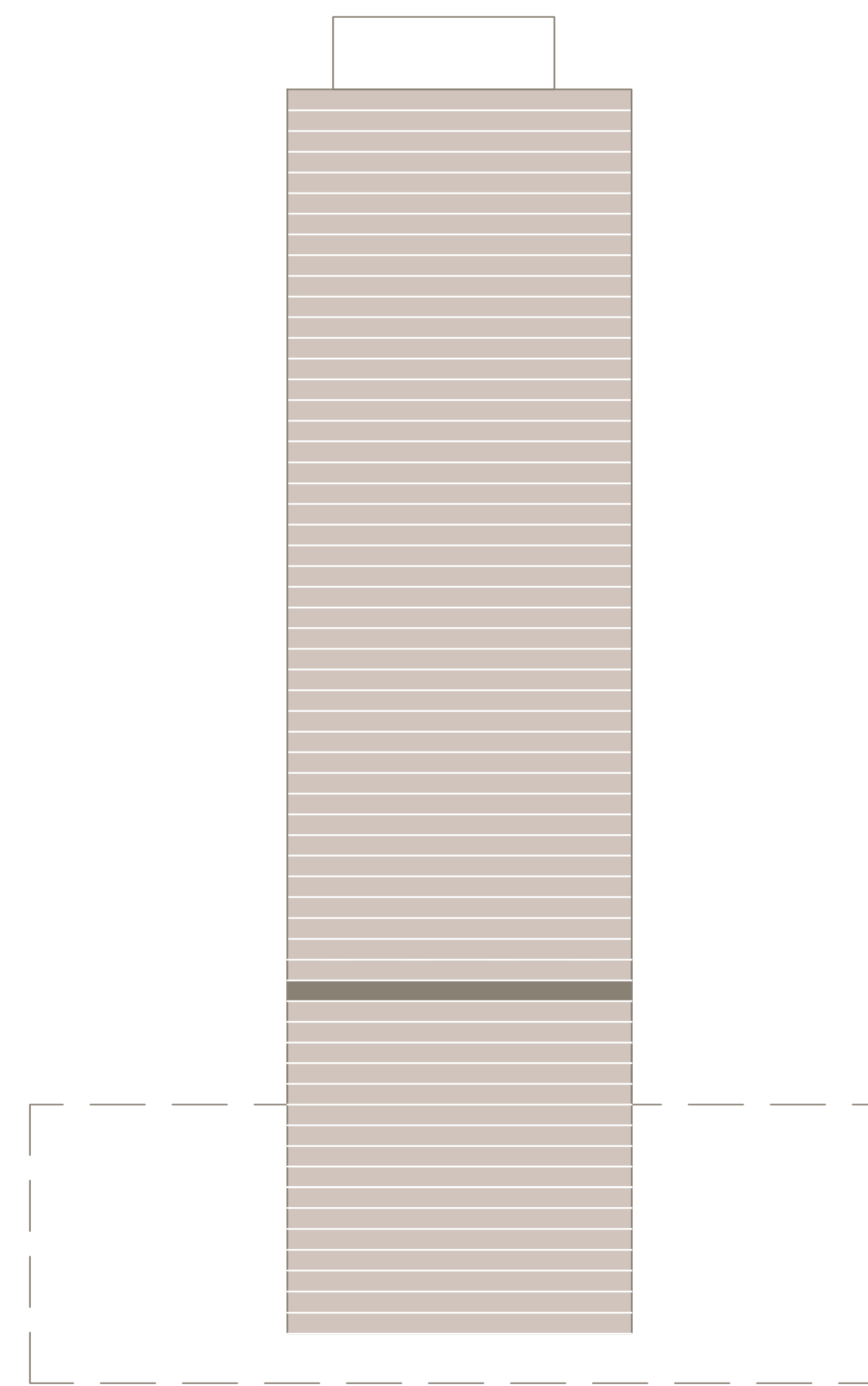

Disclaimer : All dimensions are in imperial and metric, and measured from finish to finish excluding construction tolerances. 2. All materials, dimensions, and drawings are approximate only. 3. Information is subject to change without notice, at developer's absolute discretion. 4. Actual area may vary from the stated area. 5. Drawings not to scale. 6. All images used are for illustrative purposes only and do not represent the actual size, features, specifications, fittings, and furnishings. 7. The developer reserves the right to make revisions / alterations, at its absolute discretion, without any liability whatsoever.



# ADDRESS RESIDENCES THE BAY

## 1 BEDROOM TYPE A 11

LEVEL 17 | UNIT 04

SUITE AREA	917.95 SQ.FT.	85.28 SQ.M.
BALCONY AREA	274.69 SQ.FT.	25.52 SQ.M.
TOTAL AREA	1192.64 SQ.FT.	110.80 SQ.M.

KEY PLAN LEVEL

17

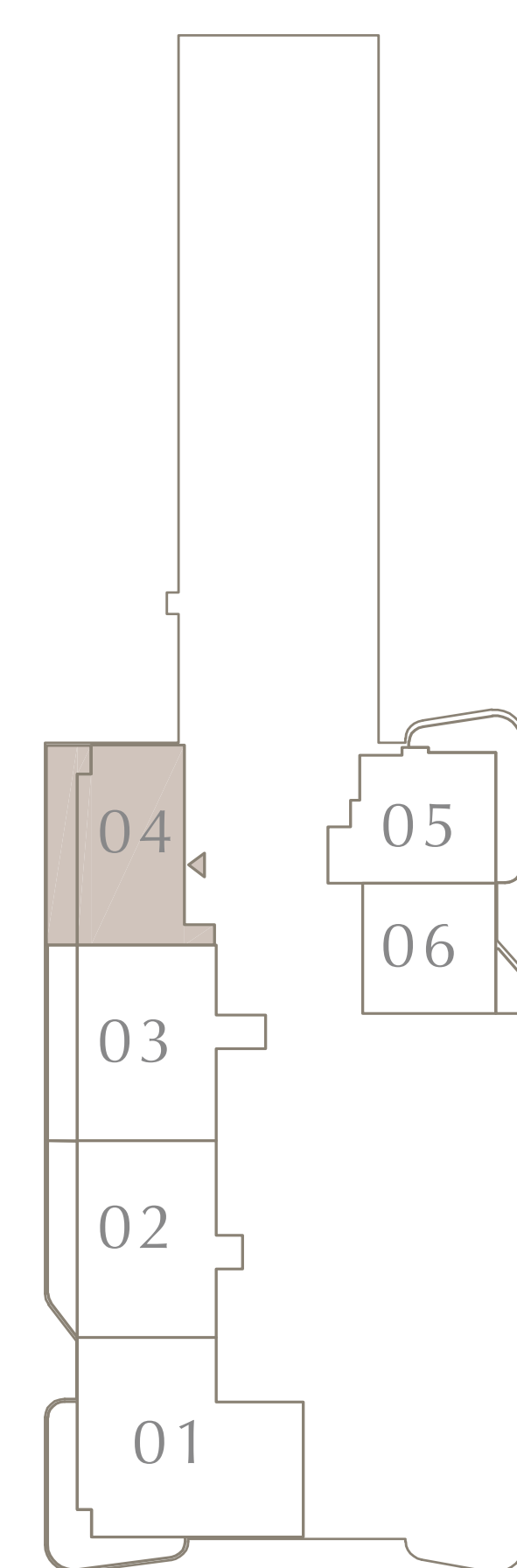
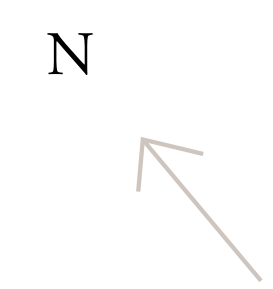

KEY SECTION

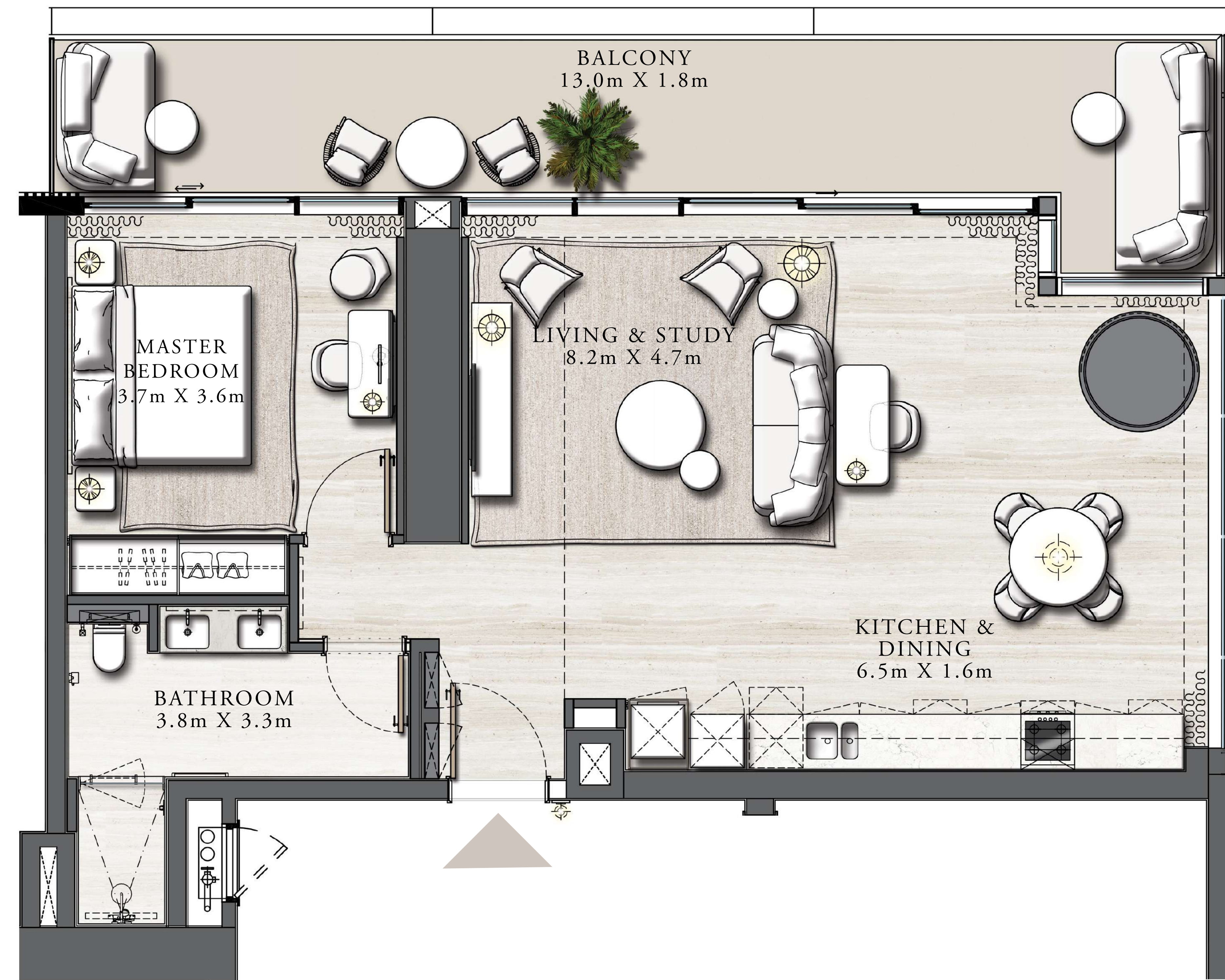
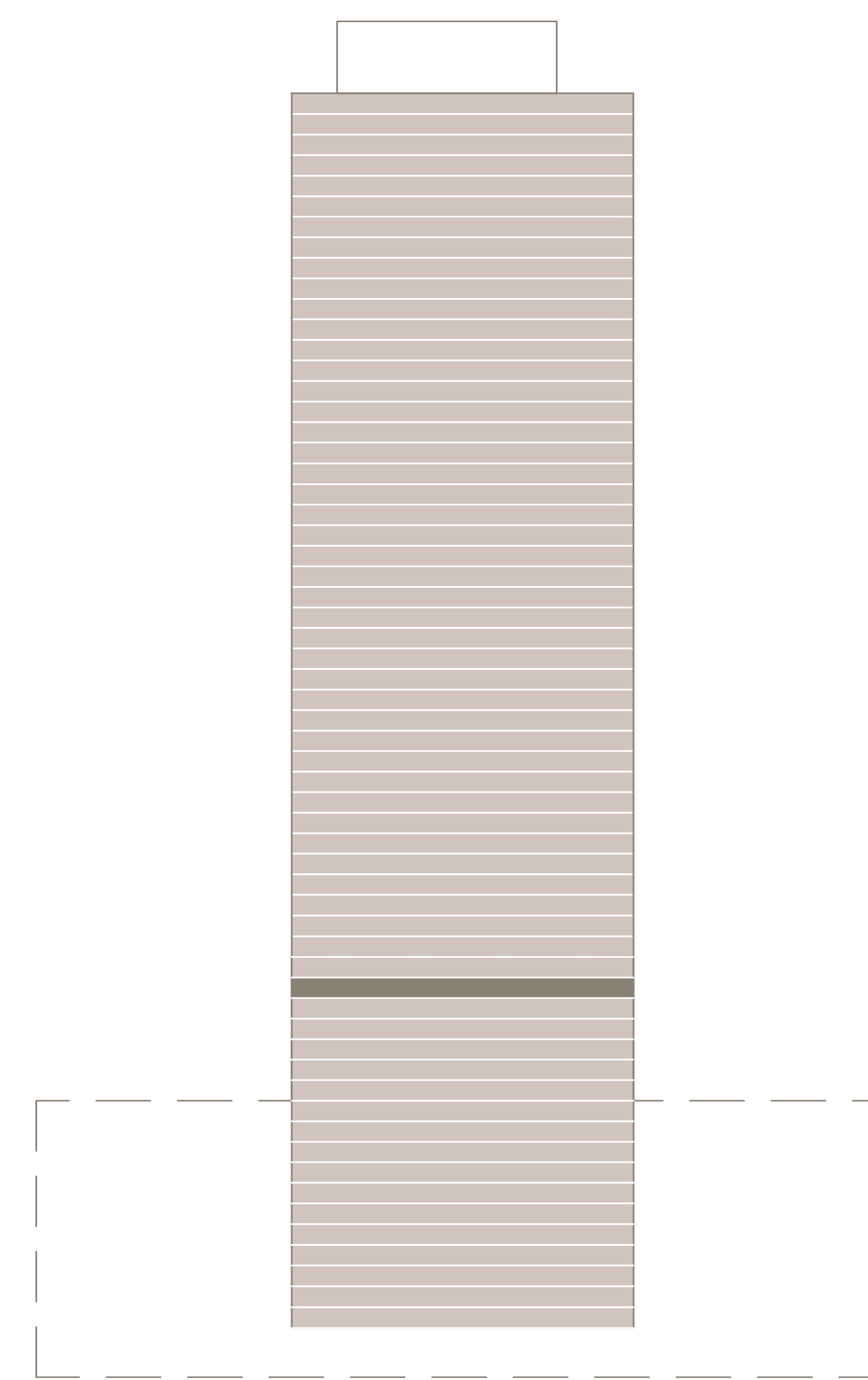

Disclaimer : All dimensions are in imperial and metric, and measured from finish to finish excluding construction tolerances. 2. All materials, dimensions, and drawings are approximate only. 3. Information is subject to change without notice, at developer's absolute discretion. 4. Actual area may vary from the stated area. 5. Drawings not to scale. 6. All images used are for illustrative purposes only and do not represent the actual size, features, specifications, fittings, and furnishings. 7. The developer reserves the right to make revisions / alterations, at its absolute discretion, without any liability whatsoever.



# ADDRESS RESIDENCES THE BAY

## 1 BEDROOM TYPE A 12

LEVEL 17 | UNIT 05

SUITE AREA	823.55 SQ.FT.	76.51 SQ.M.
BALCONY AREA	279.32 SQ.FT.	25.95 SQ.M.
TOTAL AREA	1102.87 SQ.FT.	102.46 SQ.M.

KEY PLAN LEVEL

17

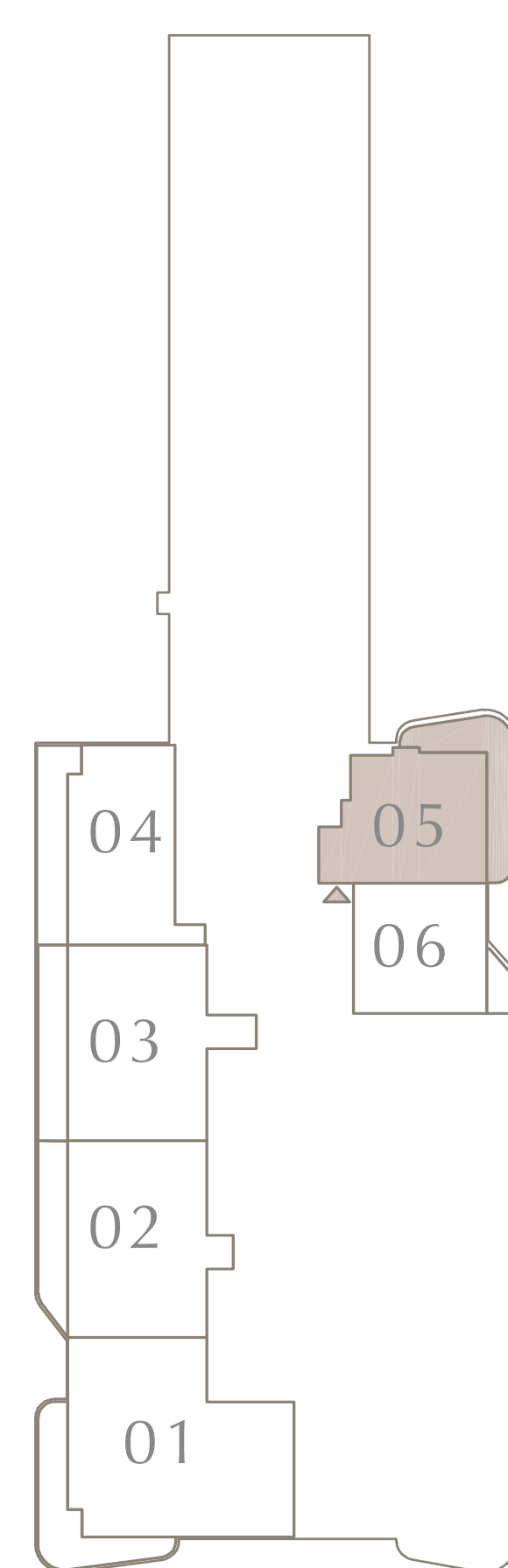
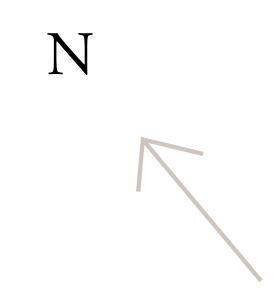

KEY SECTION

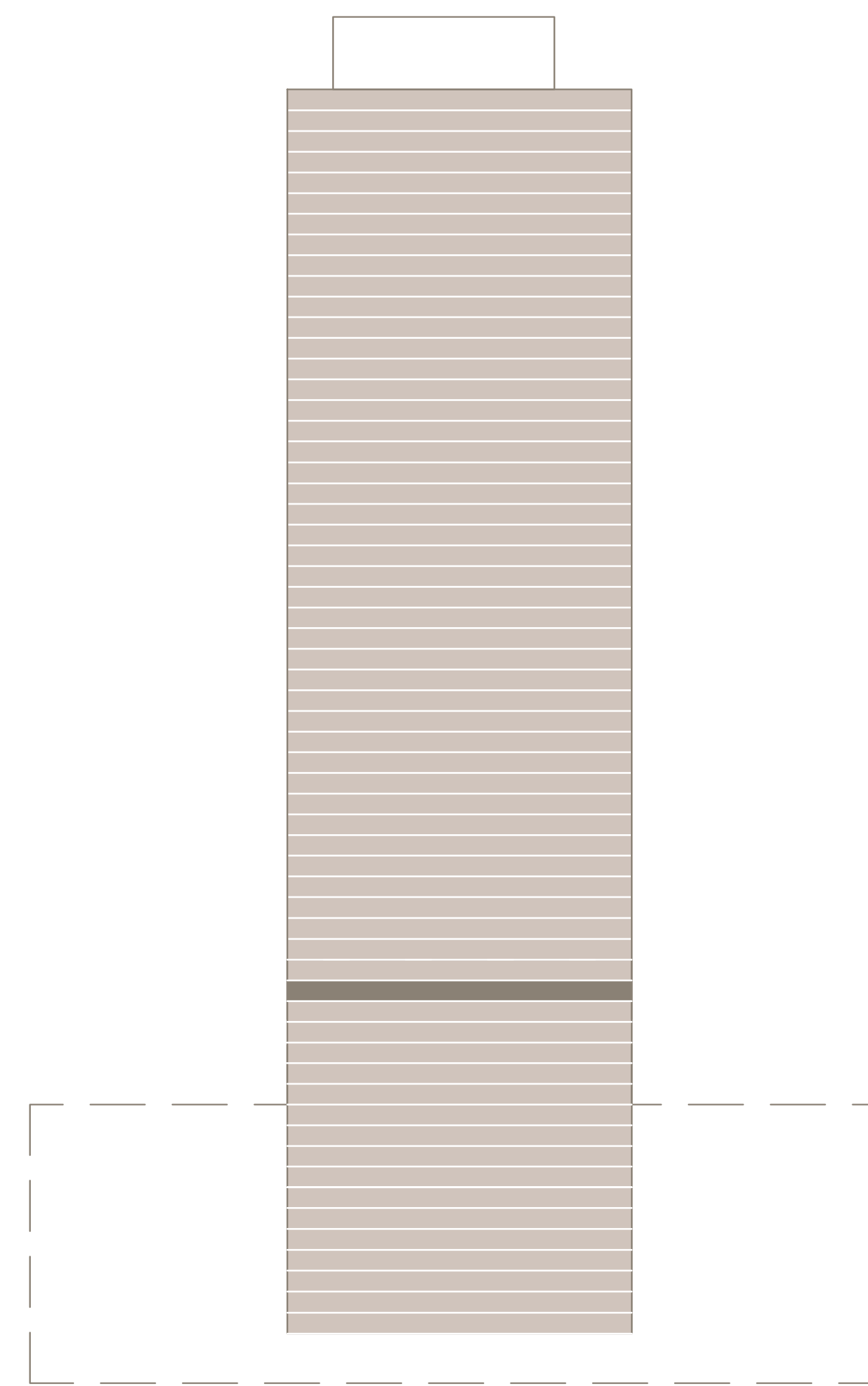

Disclaimer : All dimensions are in imperial and metric, and measured from finish to finish excluding construction tolerances. 2. All materials, dimensions, and drawings are approximate only. 3. Information is subject to change without notice, at developer's absolute discretion. 4. Actual area may vary from the stated area. 5. Drawings not to scale. 6. All images used are for illustrative purposes only and do not represent the actual size, features, specifications, fittings, and furnishings. 7. The developer reserves the right to make revisions / alterations, at its absolute discretion, without any liability whatsoever.



# ADDRESS RESIDENCES THE BAY

## 1 BEDROOM TYPE A 13

LEVEL 17 |

UNIT 06

SUITE AREA	698.90 SQ.FT.	64.93 SQ.M.
BALCONY AREA	56.73 SQ.FT.	5.27 SQ.M.
TOTAL AREA	755.63 SQ.FT.	70.20 SQ.M.

KEY PLAN LEVEL

17

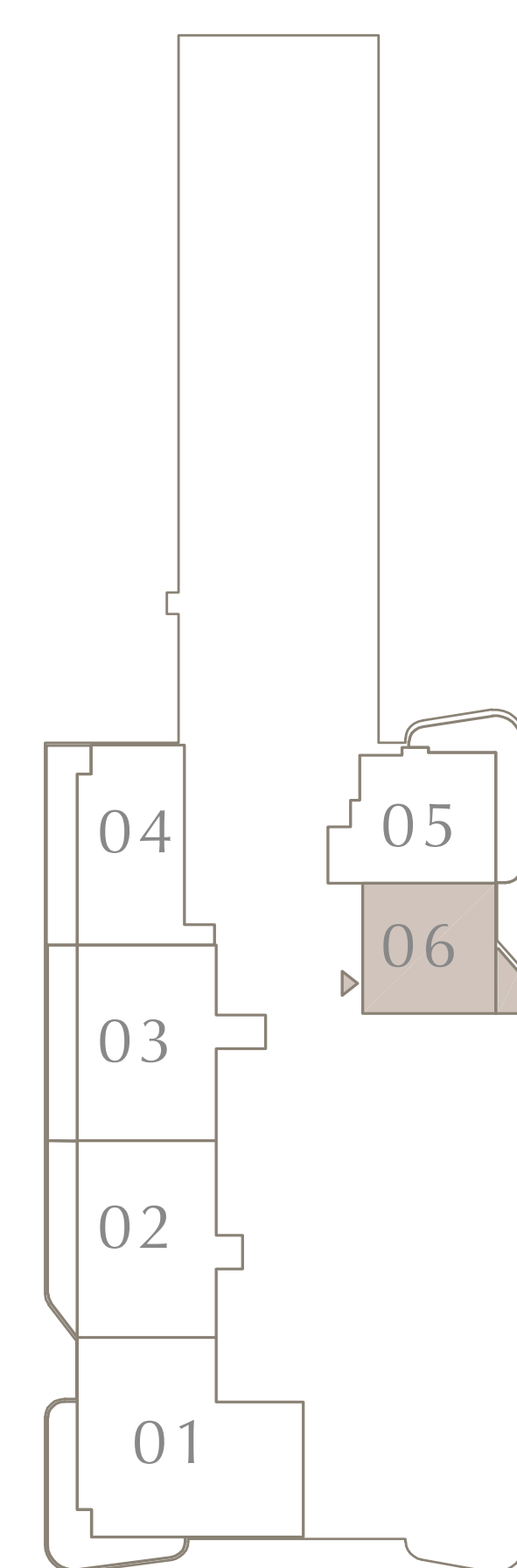
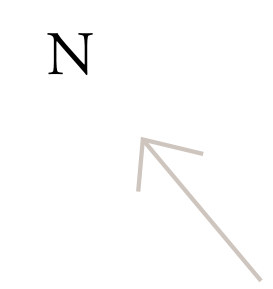

KEY SECTION

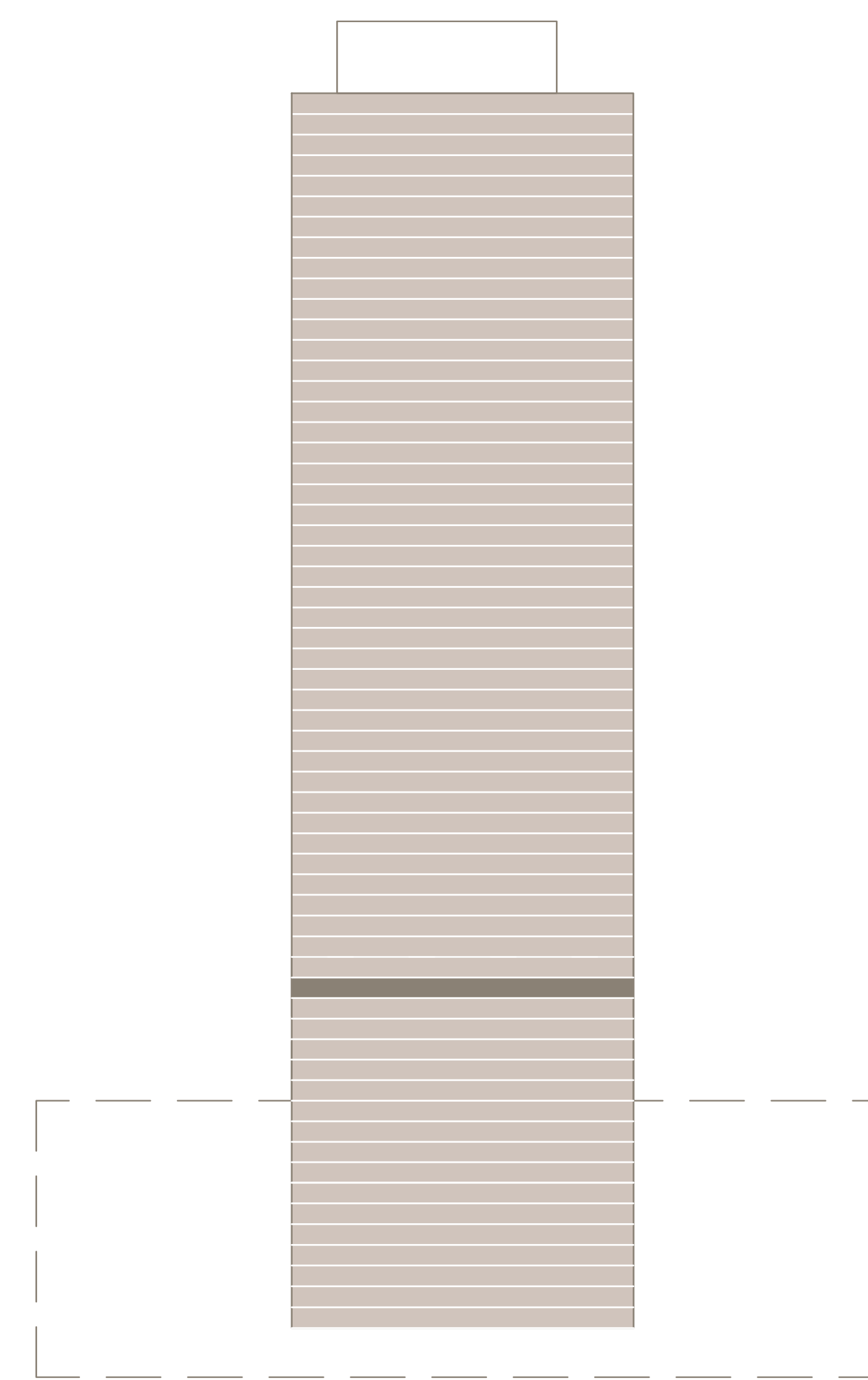

Disclaimer : All dimensions are in imperial and metric, and measured from finish to finish excluding construction tolerances. 2. All materials, dimensions, and drawings are approximate only. 3. Information is subject to change without notice, at developer's absolute discretion. 4. Actual area may vary from the stated area. 5. Drawings not to scale. 6. All images used are for illustrative purposes only and do not represent the actual size, features, specifications, fittings, and furnishings. 7. The developer reserves the right to make revisions / alterations, at its absolute discretion, without any liability whatsoever.



# ADDRESS RESIDENCES THE BAY

## 2 BEDROOM TYPE A 2

LEVEL 18 |

UNIT 01

SUITE AREA	1156.15 SQ.FT.	107.41 SQ.M.
BALCONY AREA	251.34 SQ.FT.	23.35 SQ.M.
TOTAL AREA	1407.49 SQ.FT.	130.76 SQ.M.

KEY PLAN LEVEL

18

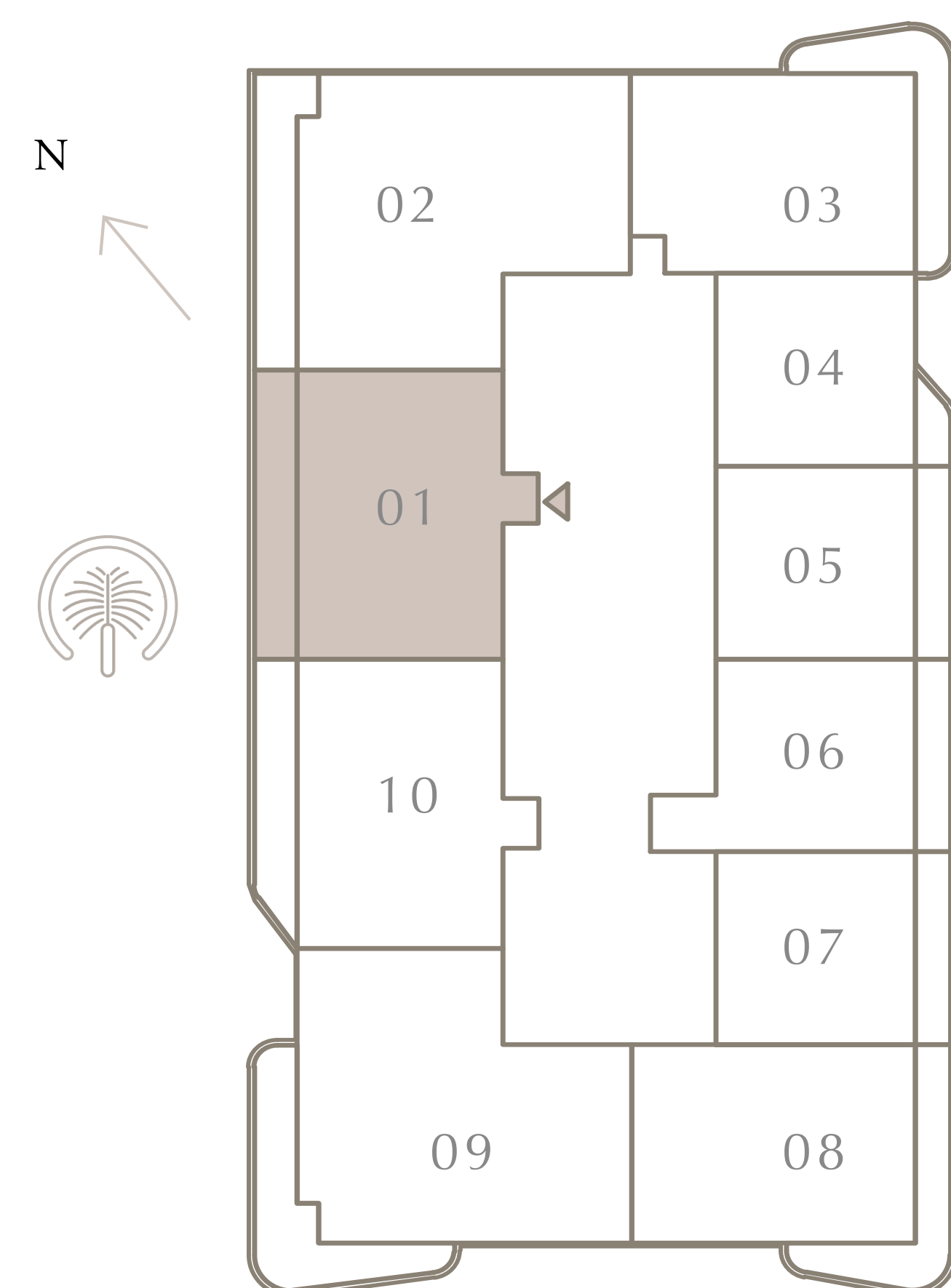

KEY SECTION

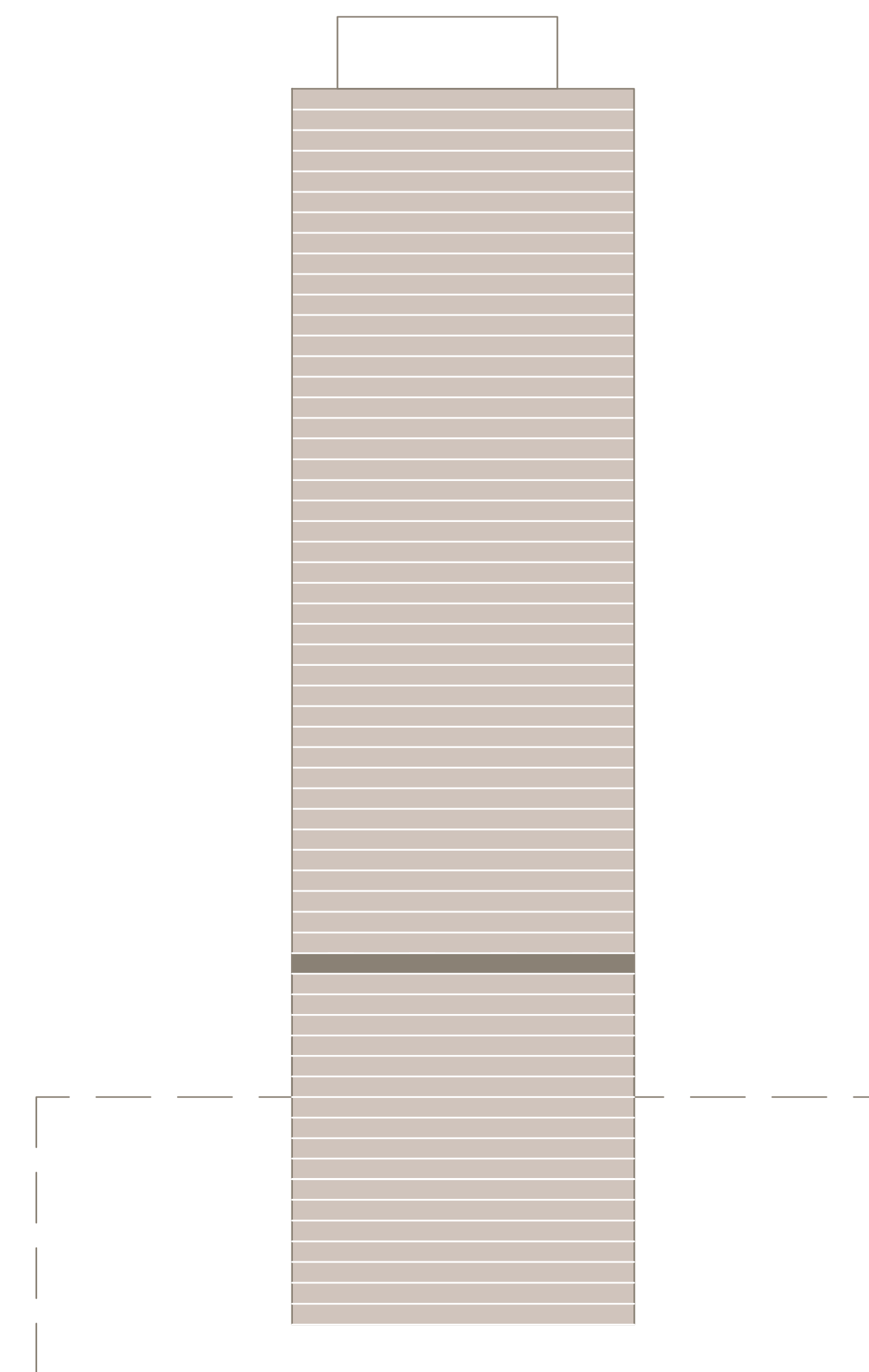

Disclaimer : All dimensions are in imperial and metric, and measured from finish to finish excluding construction tolerances. 2. All materials, dimensions, and drawings are approximate only. 3. Information is subject to change without notice, at developer's absolute discretion. 4. Actual area may vary from the stated area. 5. Drawings not to scale. 6. All images used are for illustrative purposes only and do not represent the actual size, features, specifications, fittings, and furnishings. 7. The developer reserves the right to make revisions / alterations, at its absolute discretion, without any liability whatsoever.



# ADDRESS RESIDENCES THE BAY

## 3 BEDROOM TYPE A 2

LEVEL 18 | UNIT 02

SUITE AREA	1641.50 SQ.FT.	152.50 SQ.M.
BALCONY AREA	274.80 SQ.FT.	25.53 SQ.M.
TOTAL AREA	1916.30 SQ.FT.	178.03 SQ.M.

KEY PLAN LEVEL

18

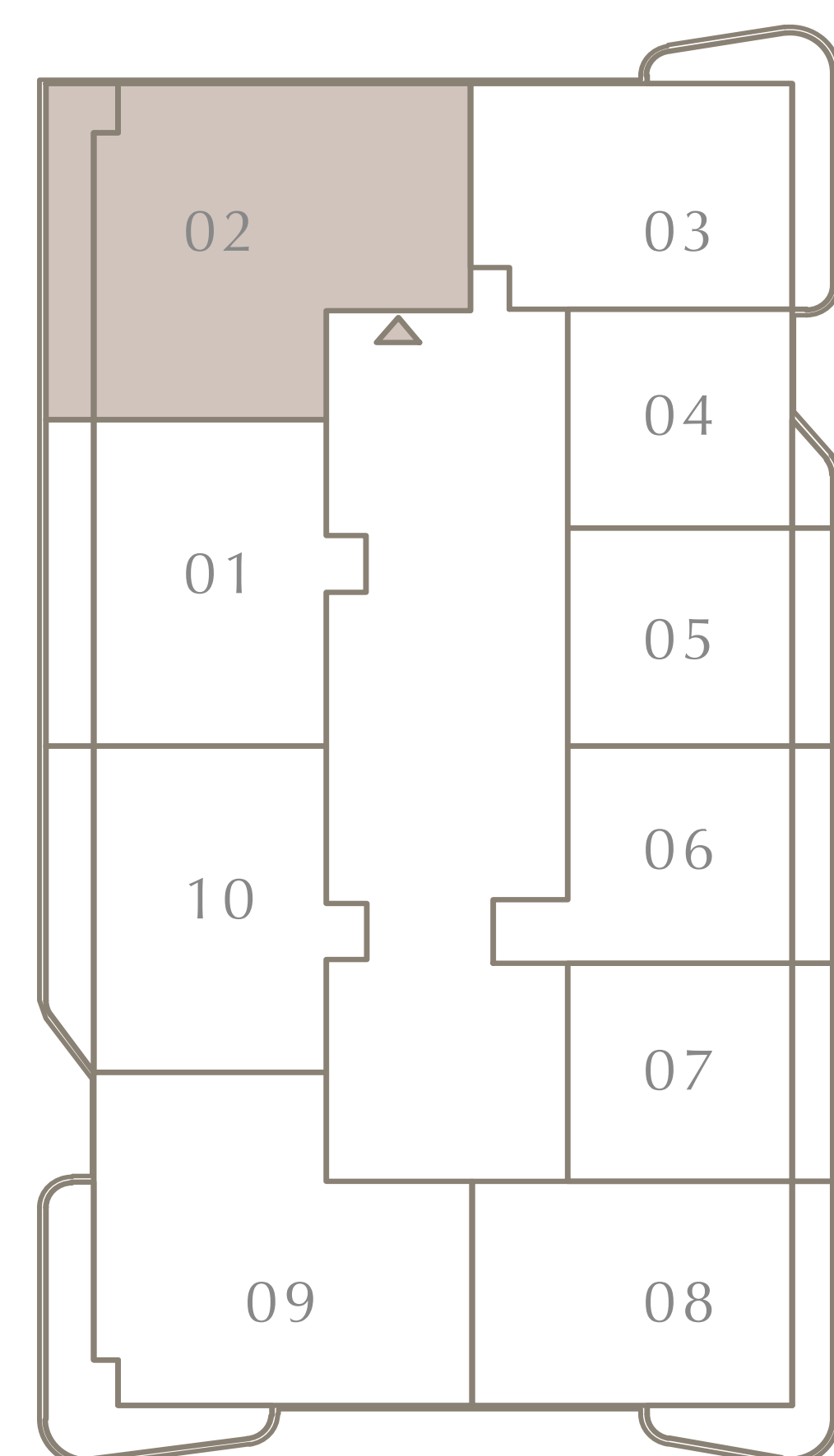

KEY SECTION

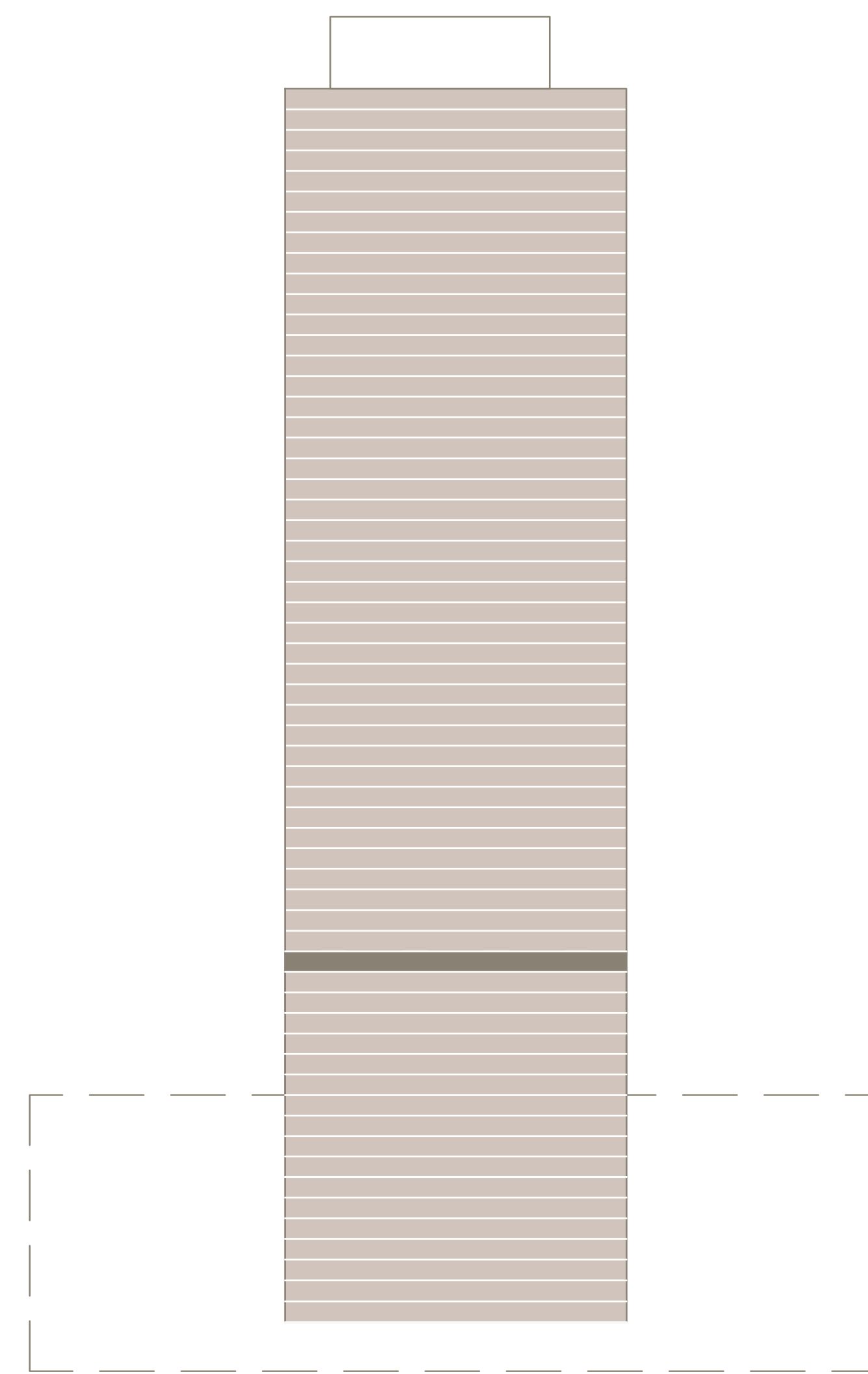

Disclaimer : All dimensions are in imperial and metric, and measured from finish to finish excluding construction tolerances. 2. All materials, dimensions, and drawings are approximate only. 3. Information is subject to change without notice, at developer's absolute discretion. 4. Actual area may vary from the stated area. 5. Drawings not to scale. 6. All images used are for illustrative purposes only and do not represent the actual size, features, specifications, fittings, and furnishings. 7. The developer reserves the right to make revisions / alterations, at its absolute discretion, without any liability whatsoever.



# ADDRESS RESIDENCES THE BAY

## 2 BEDROOM TYPE A 4

LEVEL 18 | UNIT 03

SUITE AREA	1051.85 SQ.FT.	97.72 SQ.M.
BALCONY AREA	267.81 SQ.FT.	24.88 SQ.M.
TOTAL AREA	1319.66 SQ.FT.	122.60 SQ.M.

KEY PLAN LEVEL

18

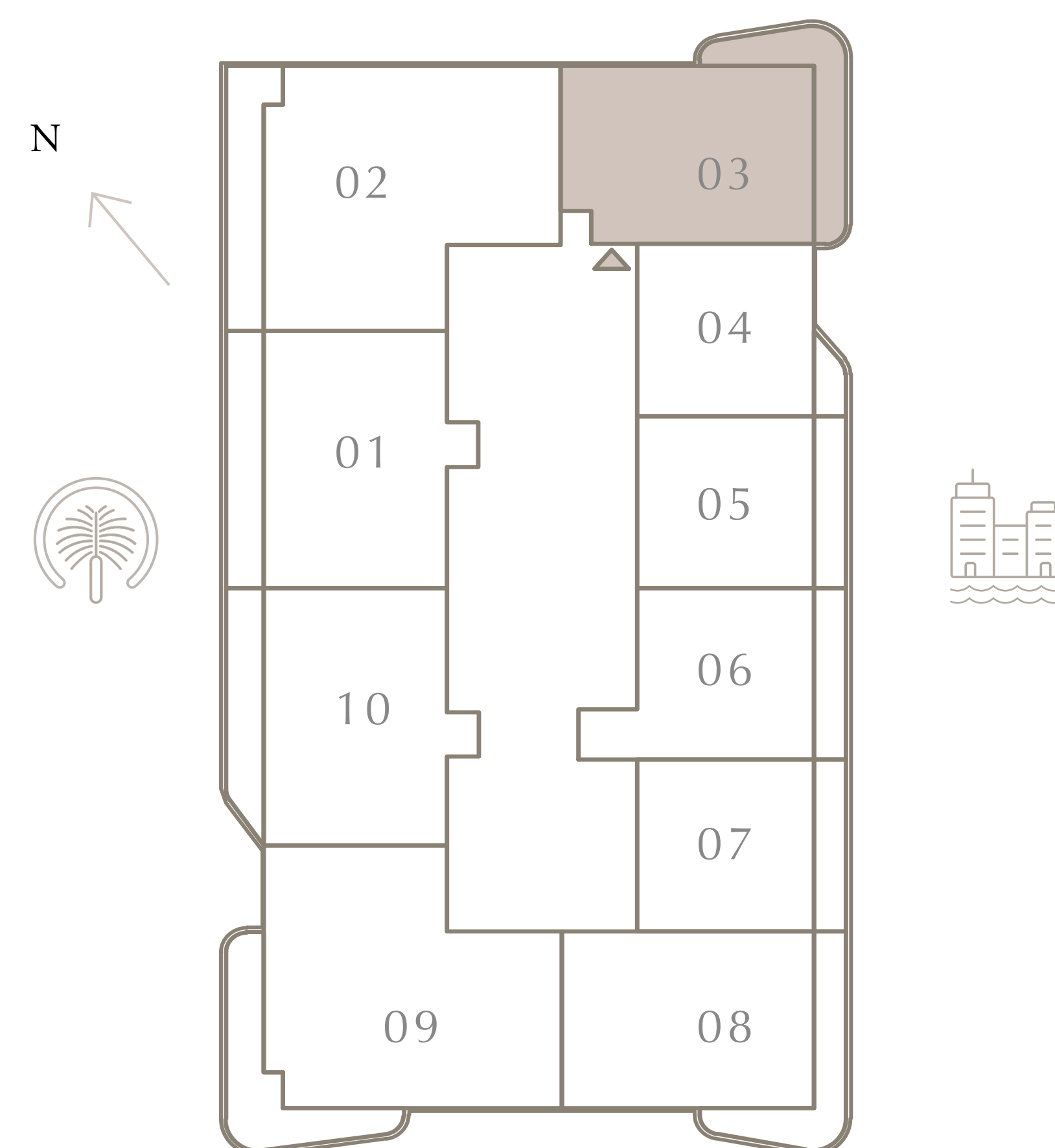

KEY SECTION

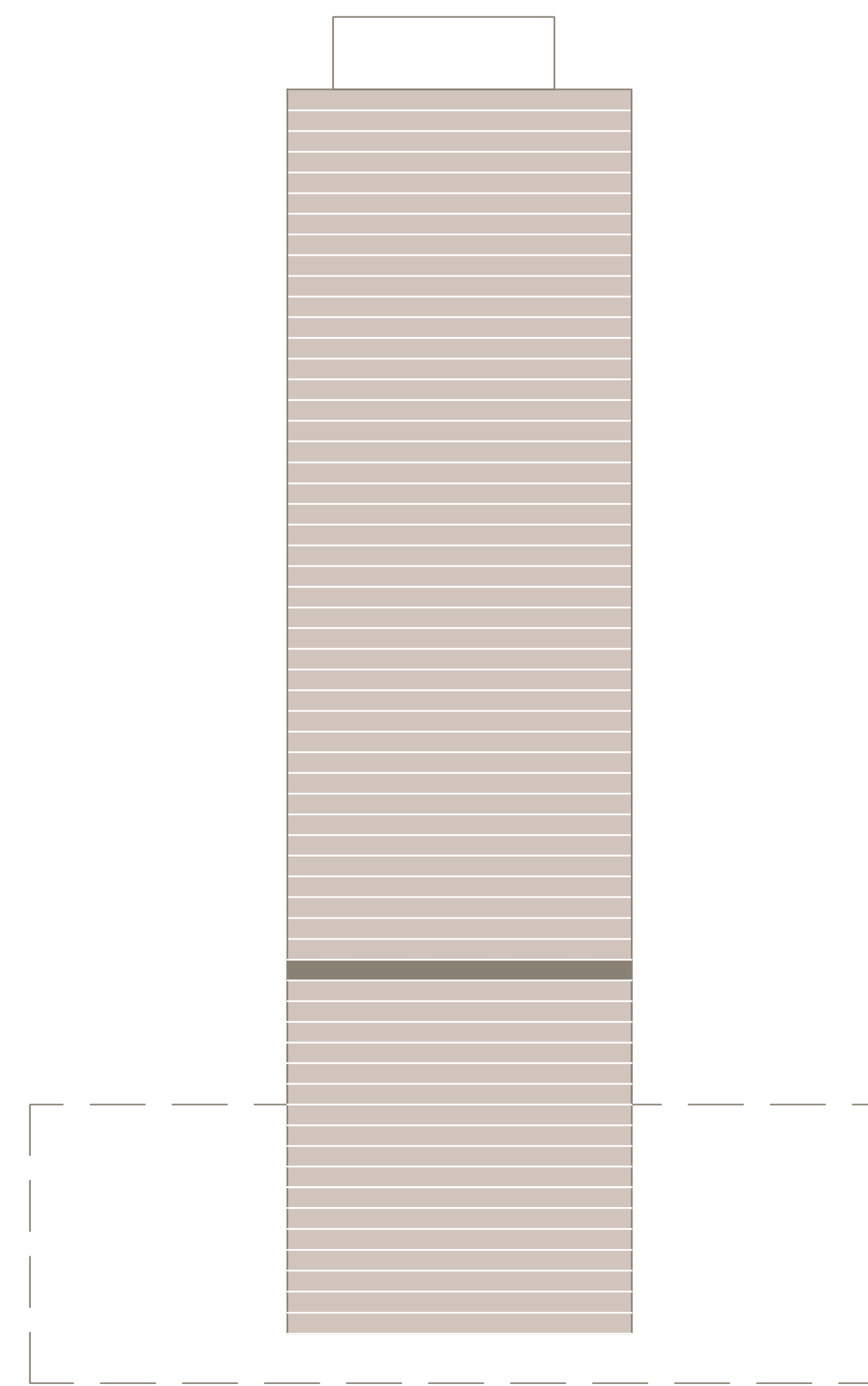

Disclaimer : All dimensions are in imperial and metric, and measured from finish to finish excluding construction tolerances. 2. All materials, dimensions, and drawings are approximate only. 3. Information is subject to change without notice, at developer's absolute discretion. 4. Actual area may vary from the stated area. 5. Drawings not to scale. 6. All images used are for illustrative purposes only and do not represent the actual size, features, specifications, fittings, and furnishings. 7. The developer reserves the right to make revisions / alterations, at its absolute discretion, without any liability whatsoever.





# ADDRESS RESIDENCES THE BAY

## 1 BEDROOM TYPE A 3

LEVEL 18 |

UNIT 04

SUITE AREA	703.96 SQ.FT.	65.40 SQ.M.
BALCONY AREA	56.62 SQ.FT.	5.26 SQ.M.
TOTAL AREA	760.58 SQ.FT.	70.66 SQ.M.

KEY PLAN LEVEL

18

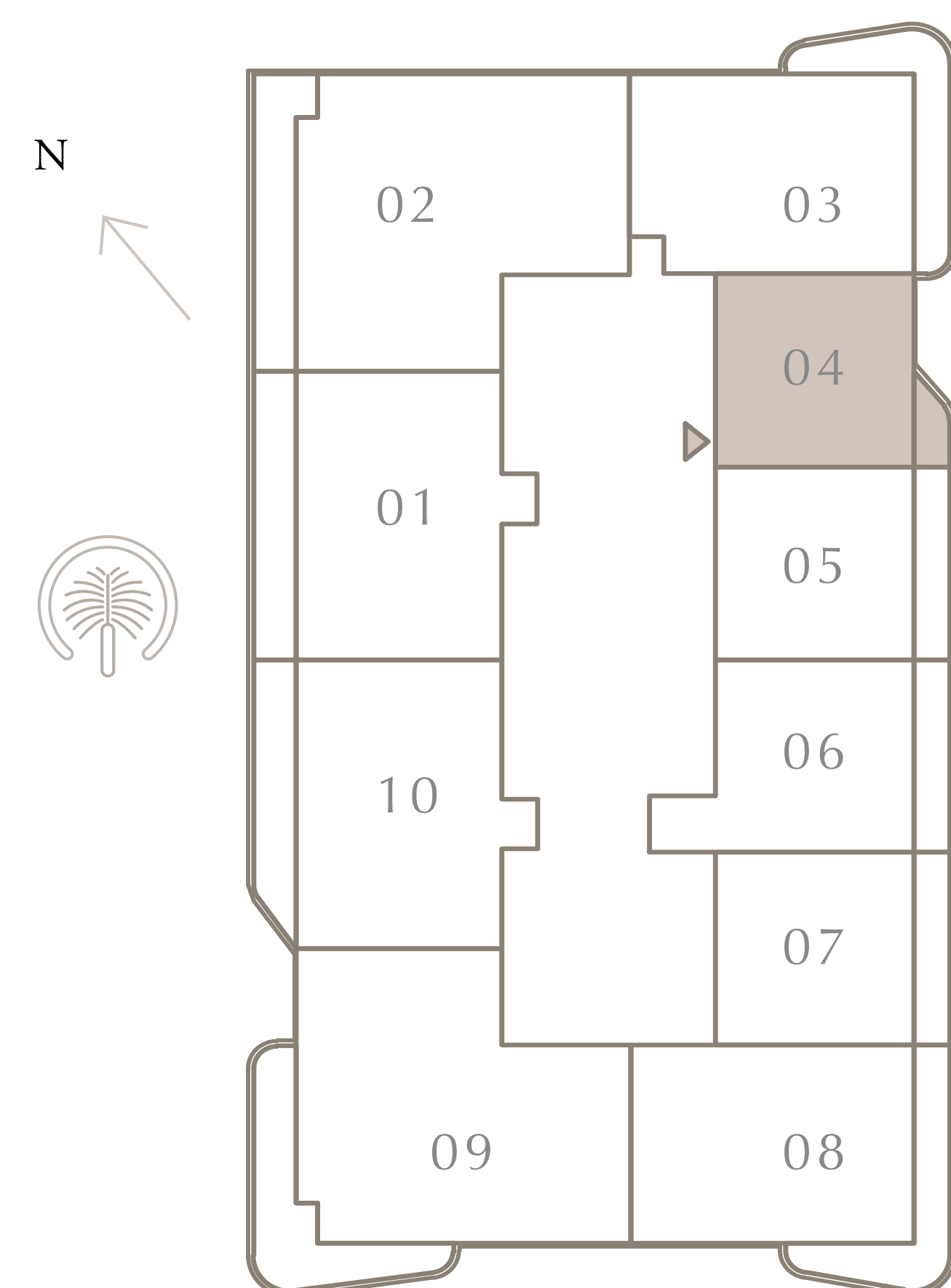

KEY SECTION

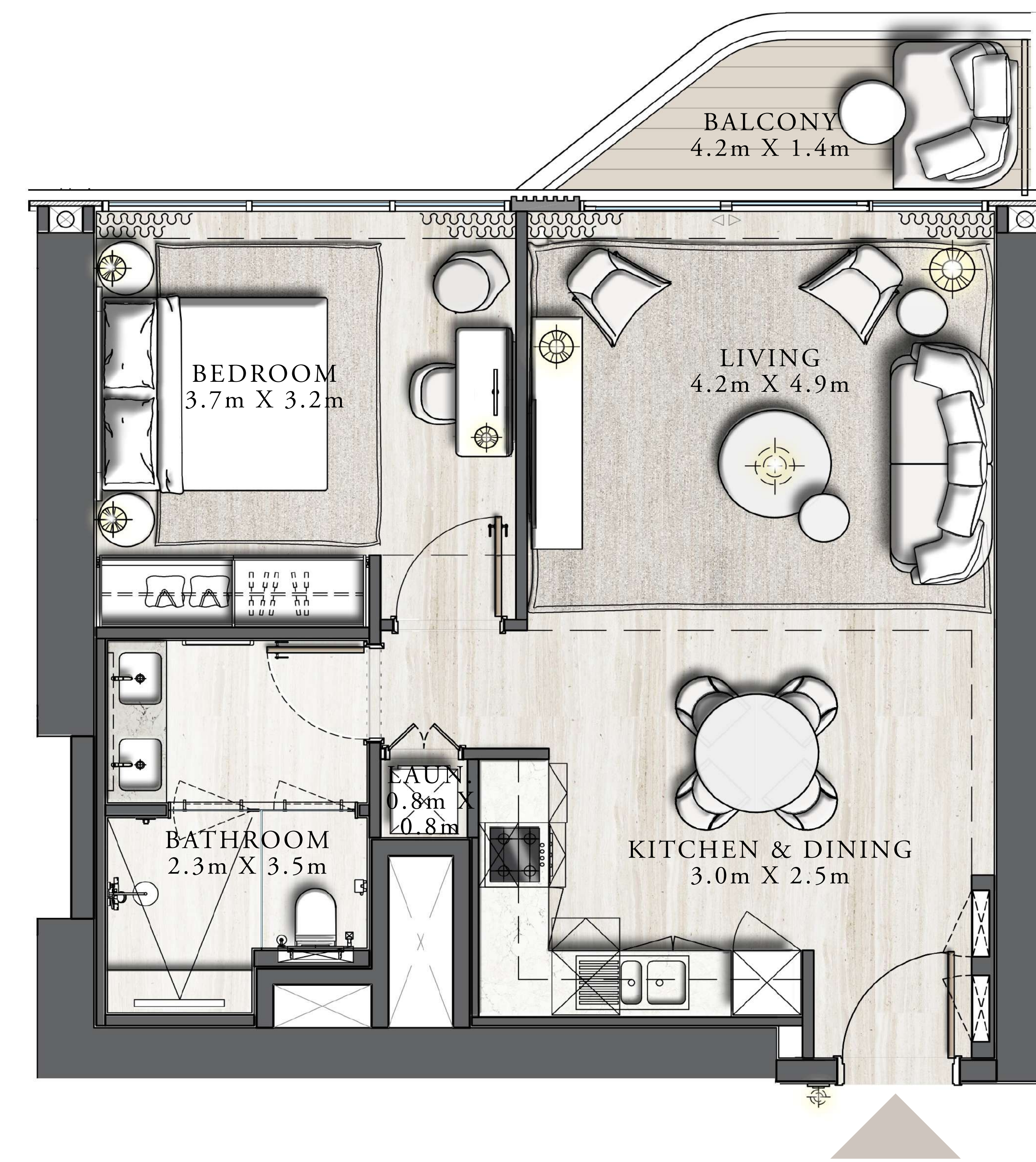
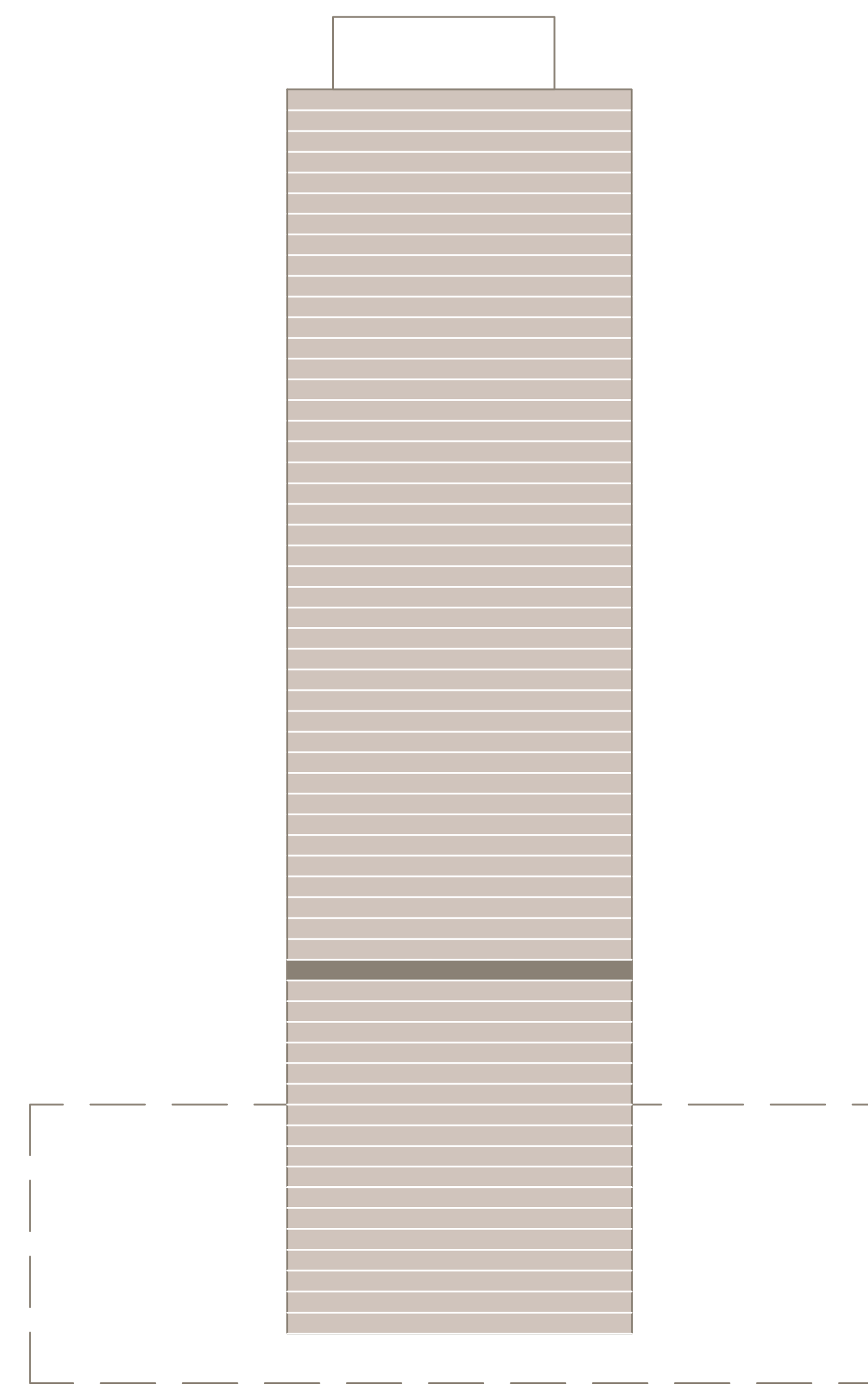

Disclaimer : All dimensions are in imperial and metric, and measured from finish to finish excluding construction tolerances. 2. All materials, dimensions, and drawings are approximate only. 3. Information is subject to change without notice, at developer's absolute discretion. 4. Actual area may vary from the stated area. 5. Drawings not to scale. 6. All images used are for illustrative purposes only and do not represent the actual size, features, specifications, fittings, and furnishings. 7. The developer reserves the right to make revisions / alterations, at its absolute discretion, without any liability whatsoever.



# ADDRESS RESIDENCES THE BAY

## 1 BEDROOM TYPE A 1

LEVEL 18 |

UNIT 05

SUITE AREA	706.76 SQ.FT.	65.66 SQ.M.
BALCONY AREA	141.98 SQ.FT.	13.19 SQ.M.
TOTAL AREA	848.74 SQ.FT.	78.85 SQ.M.

KEY PLAN LEVEL

18

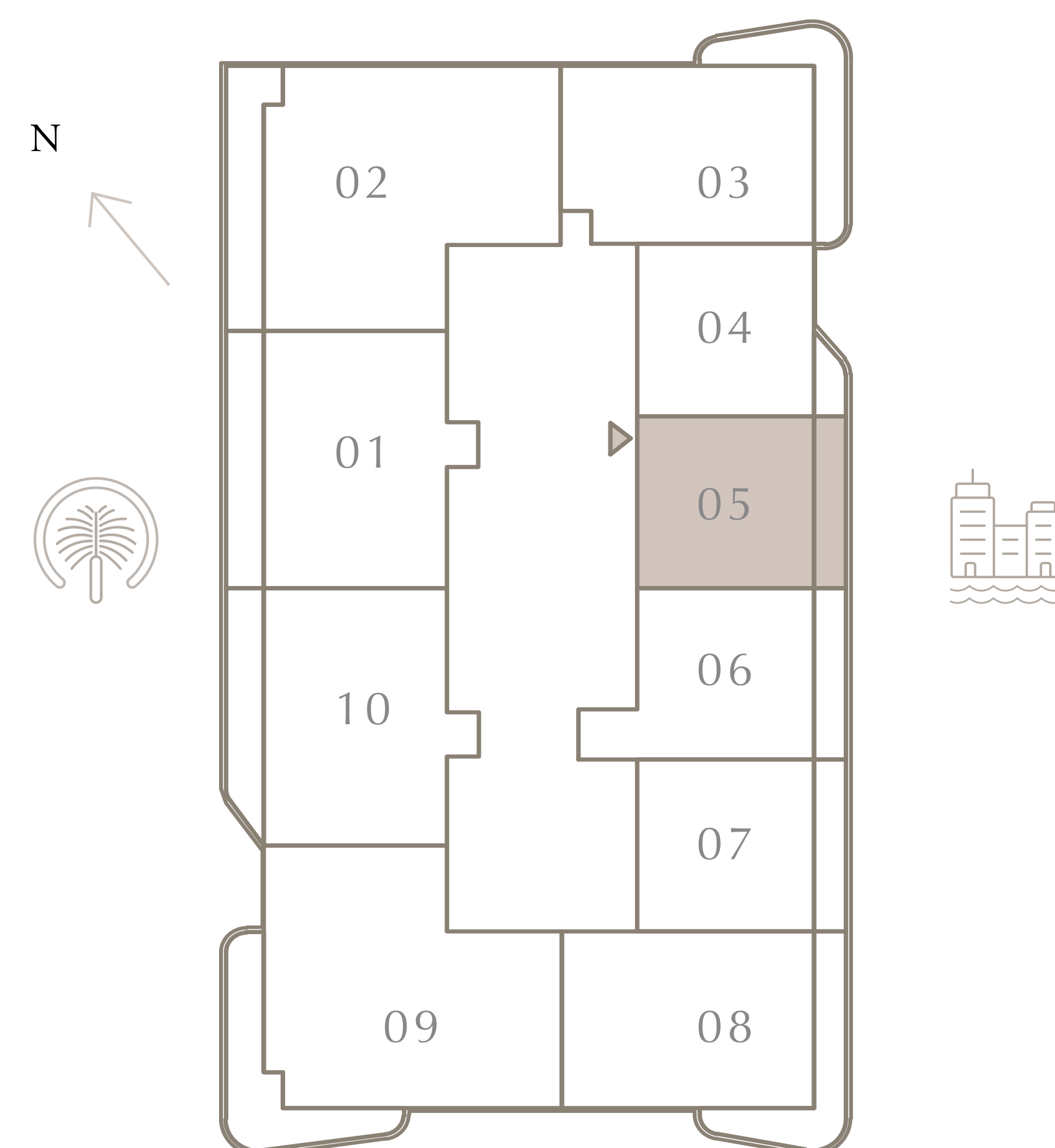

KEY SECTION

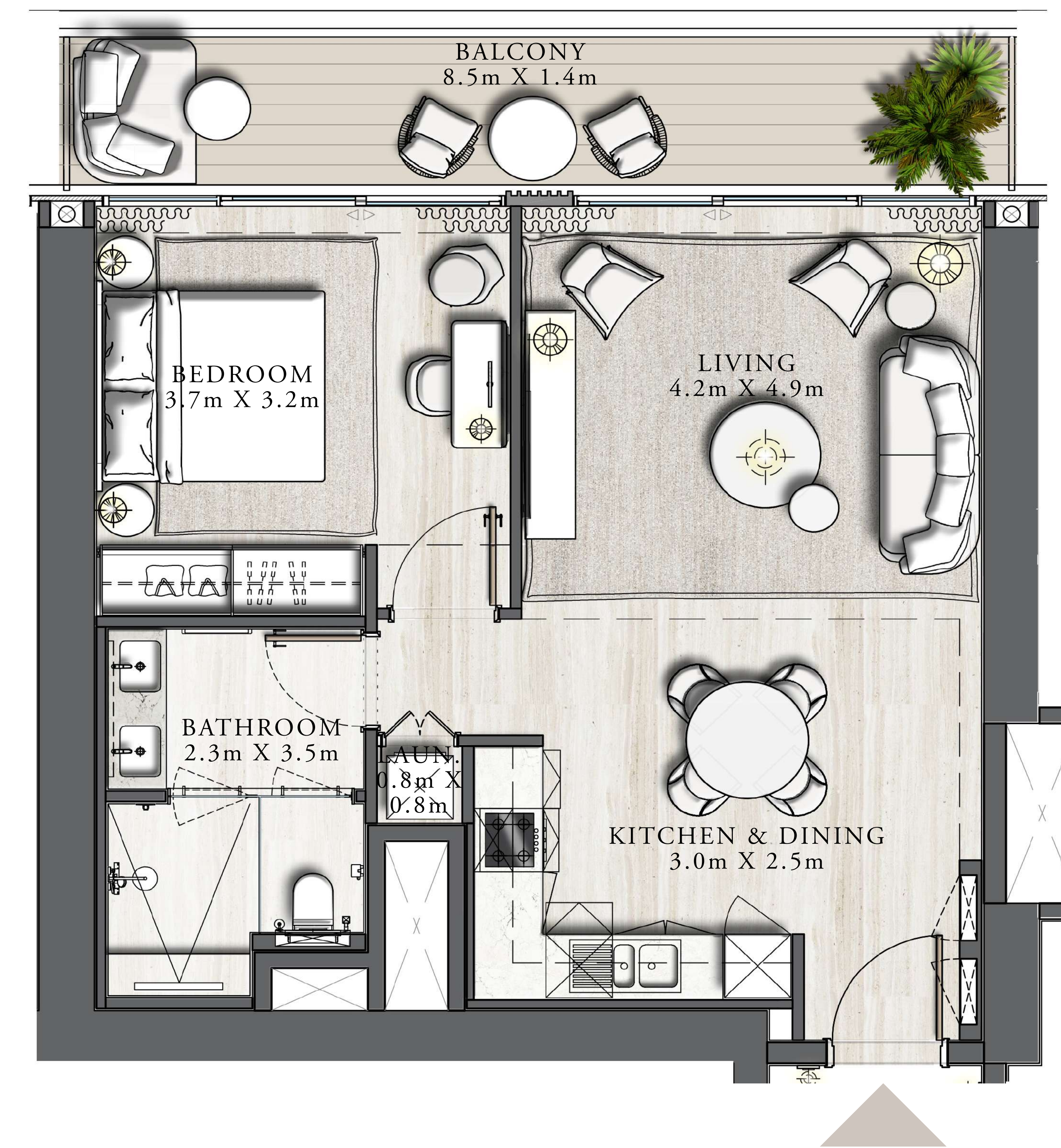
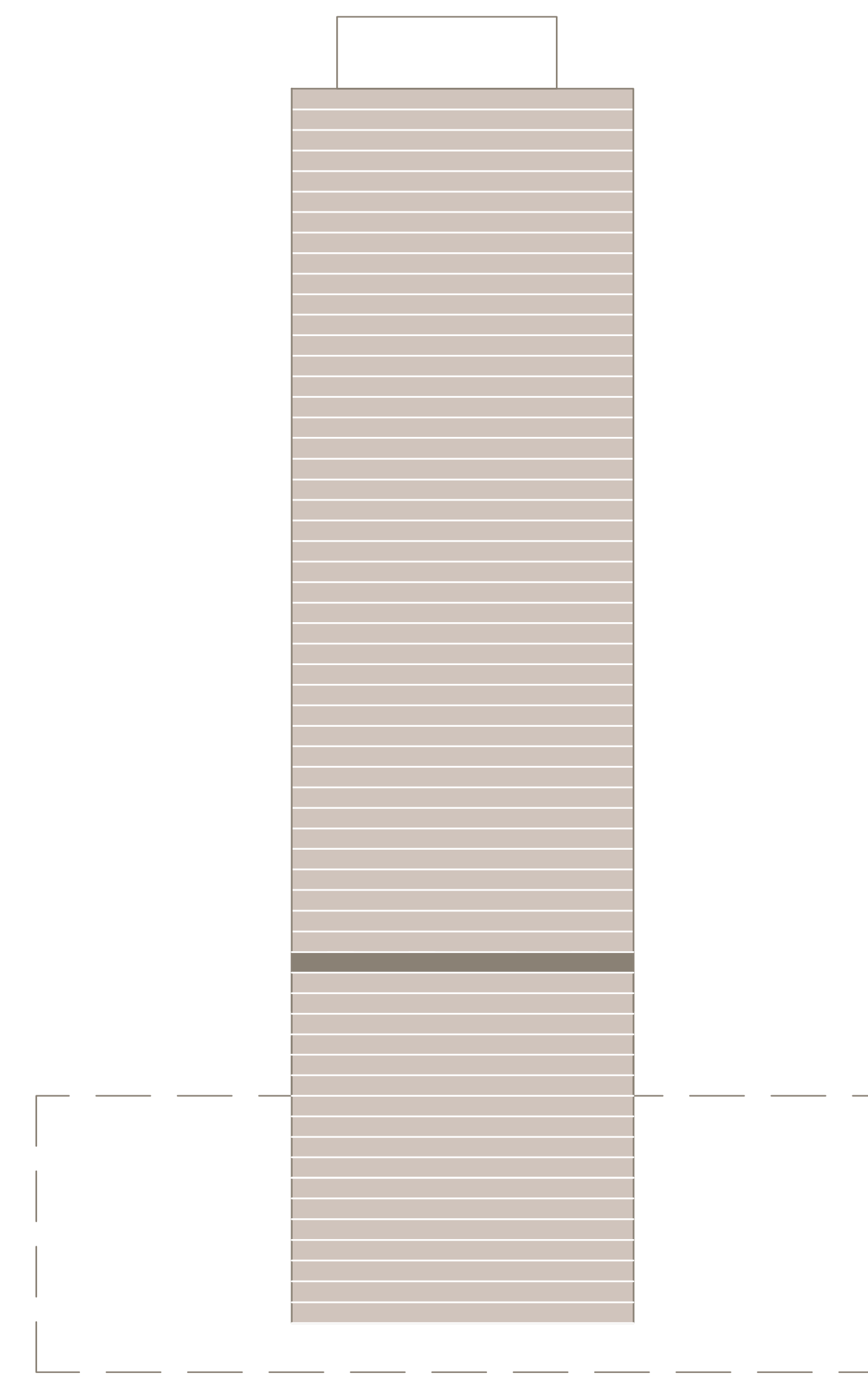

Disclaimer : All dimensions are in imperial and metric, and measured from finish to finish excluding construction tolerances. 2. All materials, dimensions, and drawings are approximate only. 3. Information is subject to change without notice, at developer's absolute discretion. 4. Actual area may vary from the stated area. 5. Drawings not to scale. 6. All images used are for illustrative purposes only and do not represent the actual size, features, specifications, fittings, and furnishings. 7. The developer reserves the right to make revisions / alterations, at its absolute discretion, without any liability whatsoever.



# ADDRESS RESIDENCES THE BAY

## 1 BEDROOM TYPE A 2

LEVEL 18 |

UNIT 06

SUITE AREA	772.63 SQ.FT.	71.78 SQ.M.
BALCONY AREA	141.98 SQ.FT.	13.19 SQ.M.
TOTAL AREA	914.61 SQ.FT.	84.97 SQ.M.

KEY PLAN LEVEL

18

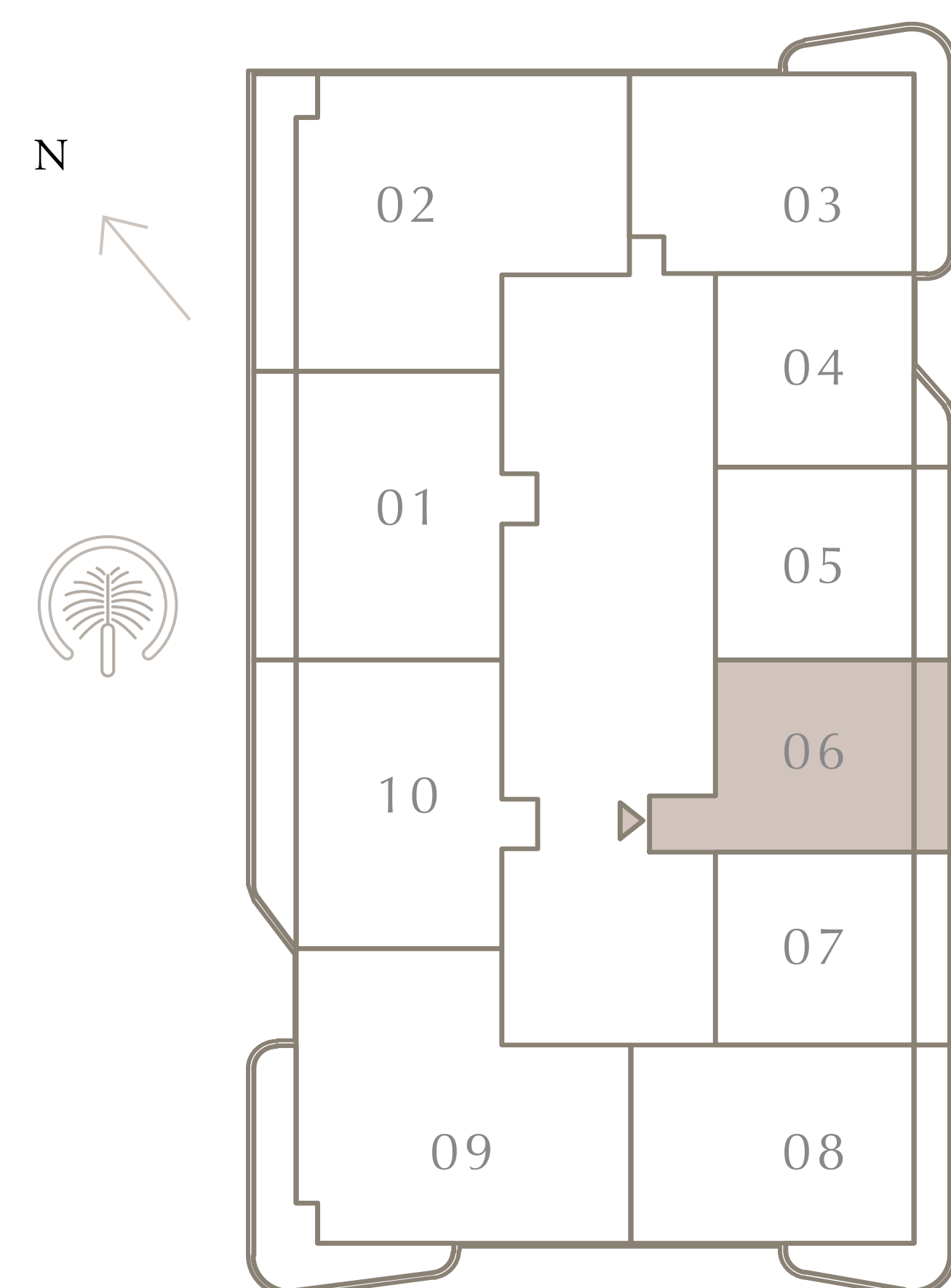

KEY SECTION

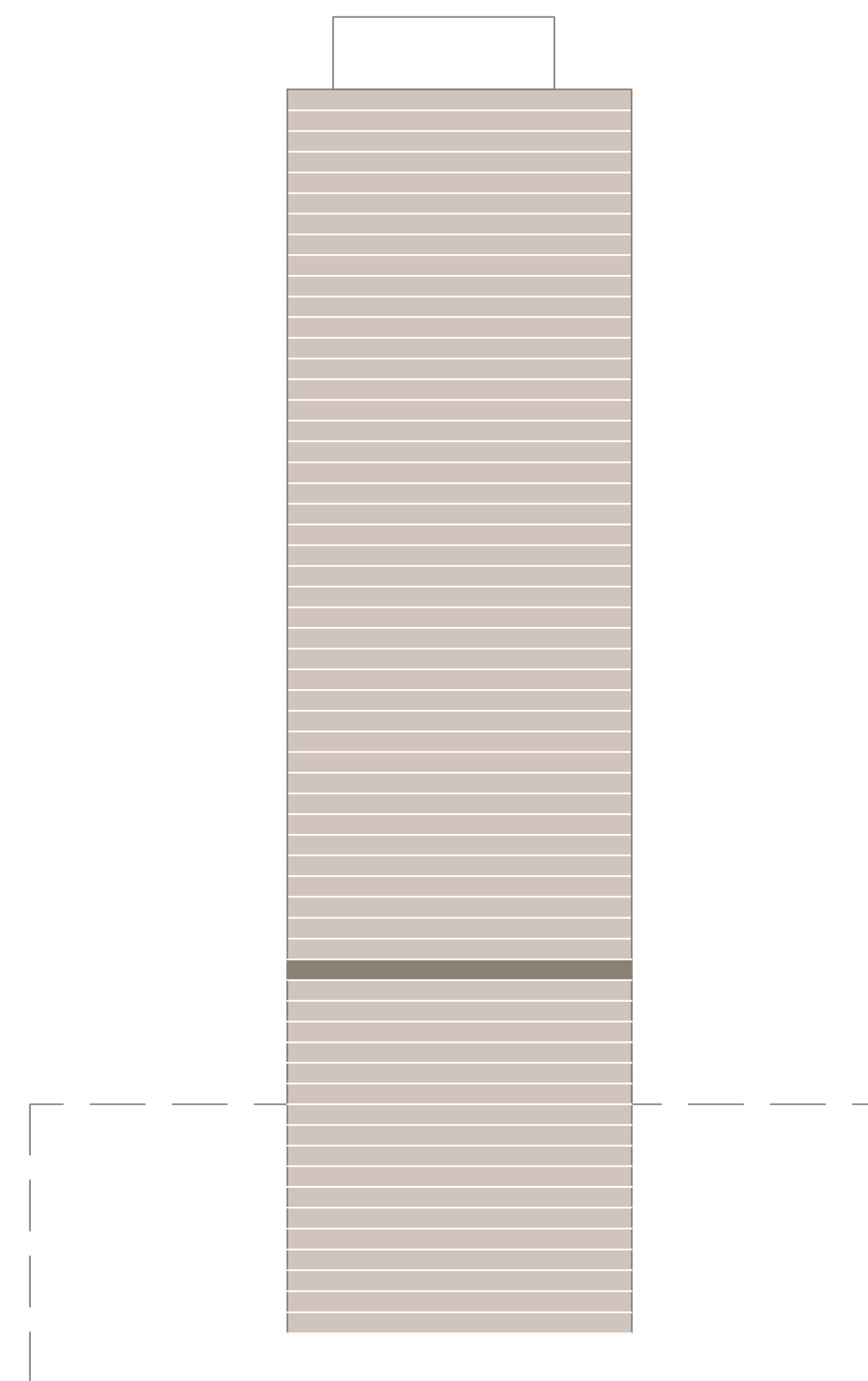

Disclaimer : All dimensions are in imperial and metric, and measured from finish to finish excluding construction tolerances. 2. All materials, dimensions, and drawings are approximate only. 3. Information is subject to change without notice, at developer's absolute discretion. 4. Actual area may vary from the stated area. 5. Drawings not to scale. 6. All images used are for illustrative purposes only and do not represent the actual size, features, specifications, fittings, and furnishings. 7. The developer reserves the right to make revisions / alterations, at its absolute discretion, without any liability whatsoever.



# ADDRESS RESIDENCES THE BAY

## 1 BEDROOM TYPE A 1

LEVEL 18 | UNIT 07

SUITE AREA	703.53 SQ.FT.	65.36 SQ.M.
BALCONY AREA	141.98 SQ.FT.	13.19 SQ.M.
TOTAL AREA	845.51 SQ.FT.	78.55 SQ.M.

KEY PLAN LEVEL

18

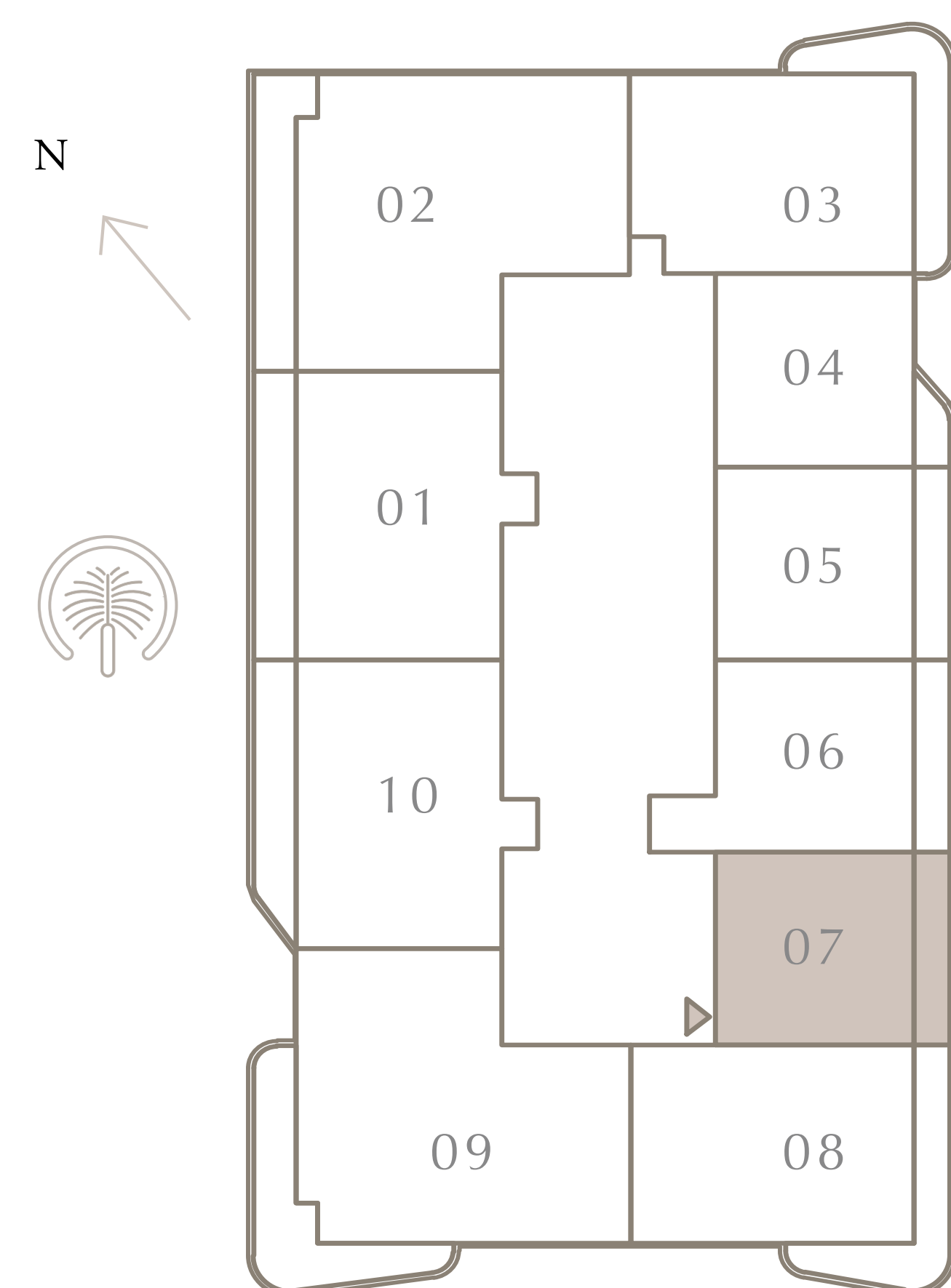

KEY SECTION

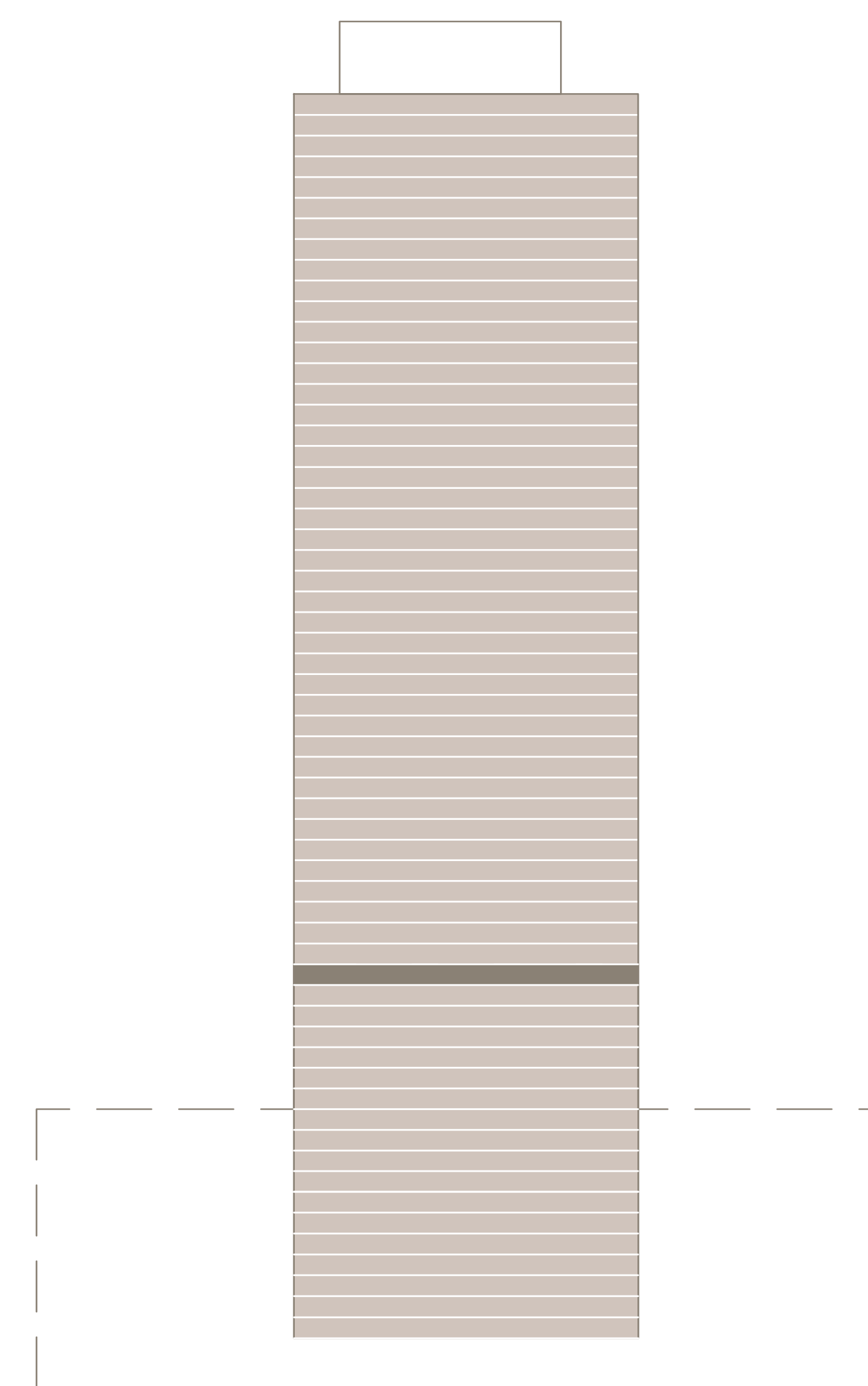

Disclaimer : All dimensions are in imperial and metric, and measured from finish to finish excluding construction tolerances. 2. All materials, dimensions, and drawings are approximate only. 3. Information is subject to change without notice, at developer's absolute discretion. 4. Actual area may vary from the stated area. 5. Drawings not to scale. 6. All images used are for illustrative purposes only and do not represent the actual size, features, specifications, fittings, and furnishings. 7. The developer reserves the right to make revisions / alterations, at its absolute discretion, without any liability whatsoever.



# ADDRESS RESIDENCES THE BAY

## 2 BEDROOM TYPE A 3

LEVEL 18 | UNIT 08

SUITE AREA	1051.20 SQ.FT.	97.66 SQ.M.
BALCONY AREA	266.30 SQ.FT.	24.74 SQ.M.
TOTAL AREA	1317.50 SQ.FT.	122.40 SQ.M.

KEY PLAN LEVEL

18

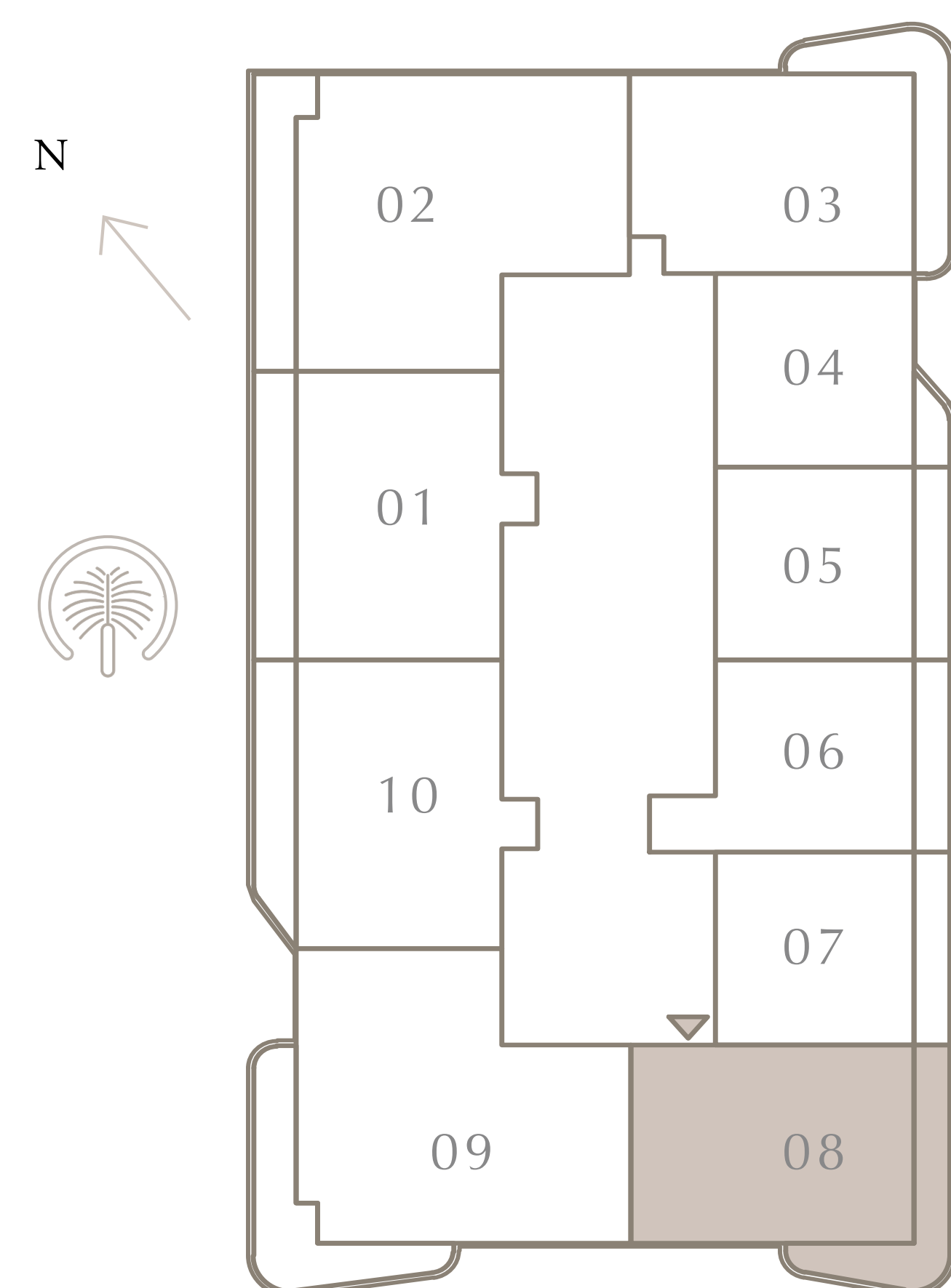

KEY SECTION

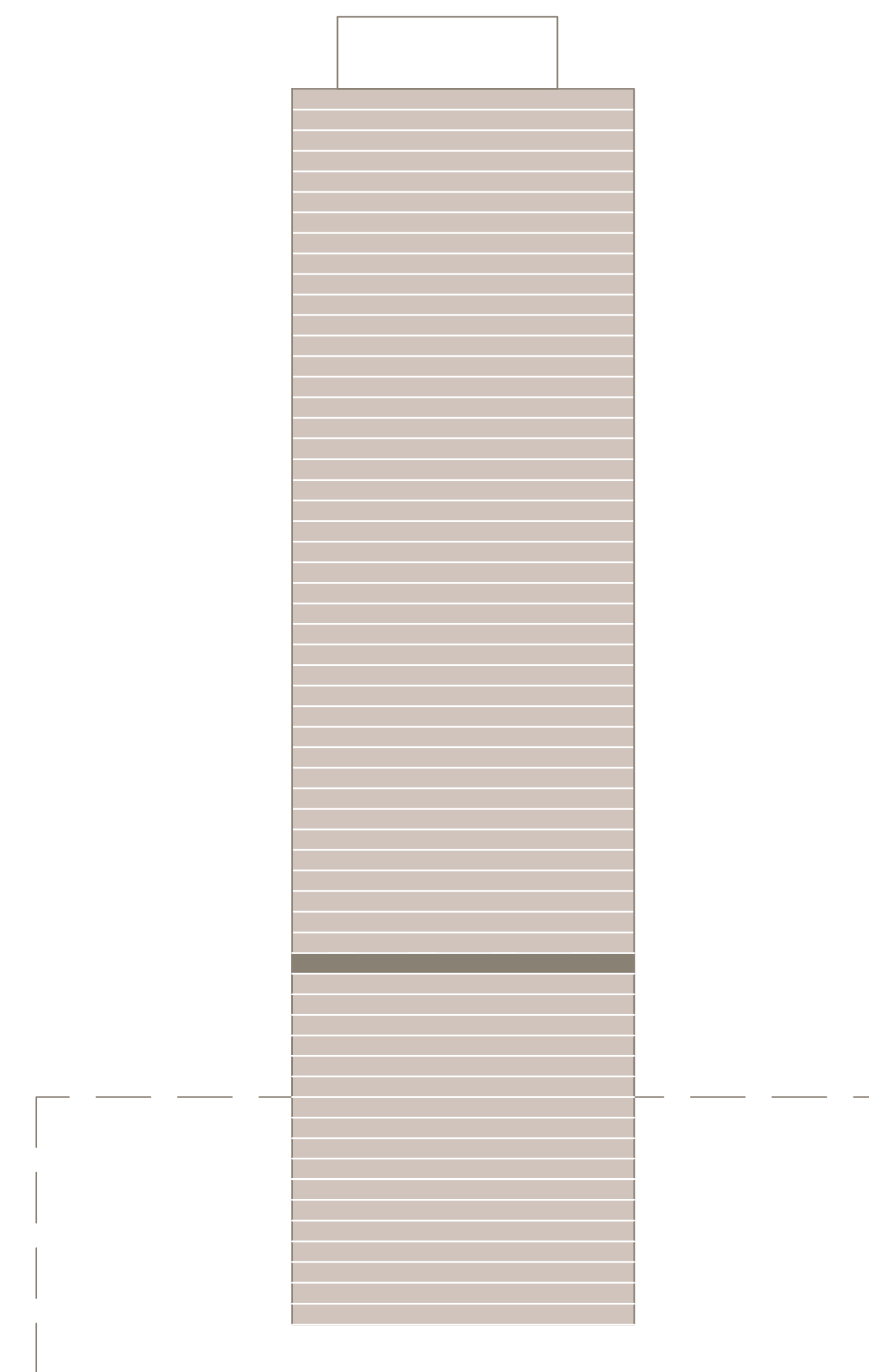

Disclaimer : All dimensions are in imperial and metric, and measured from finish to finish excluding construction tolerances. 2. All materials, dimensions, and drawings are approximate only. 3. Information is subject to change without notice, at developer's absolute discretion. 4. Actual area may vary from the stated area. 5. Drawings not to scale. 6. All images used are for illustrative purposes only and do not represent the actual size, features, specifications, fittings, and furnishings. 7. The developer reserves the right to make revisions / alterations, at its absolute discretion, without any liability whatsoever.



# ADDRESS RESIDENCES THE BAY

## 3 BEDROOM TYPE A 1

LEVEL 18 | UNIT 09

SUITE AREA	1641.71 SQ.FT.	152.52 SQ.M.
BALCONY AREA	334.97 SQ.FT.	31.12 SQ.M.
TOTAL AREA	1976.68 SQ.FT.	183.64 SQ.M.

KEY PLAN LEVEL

18

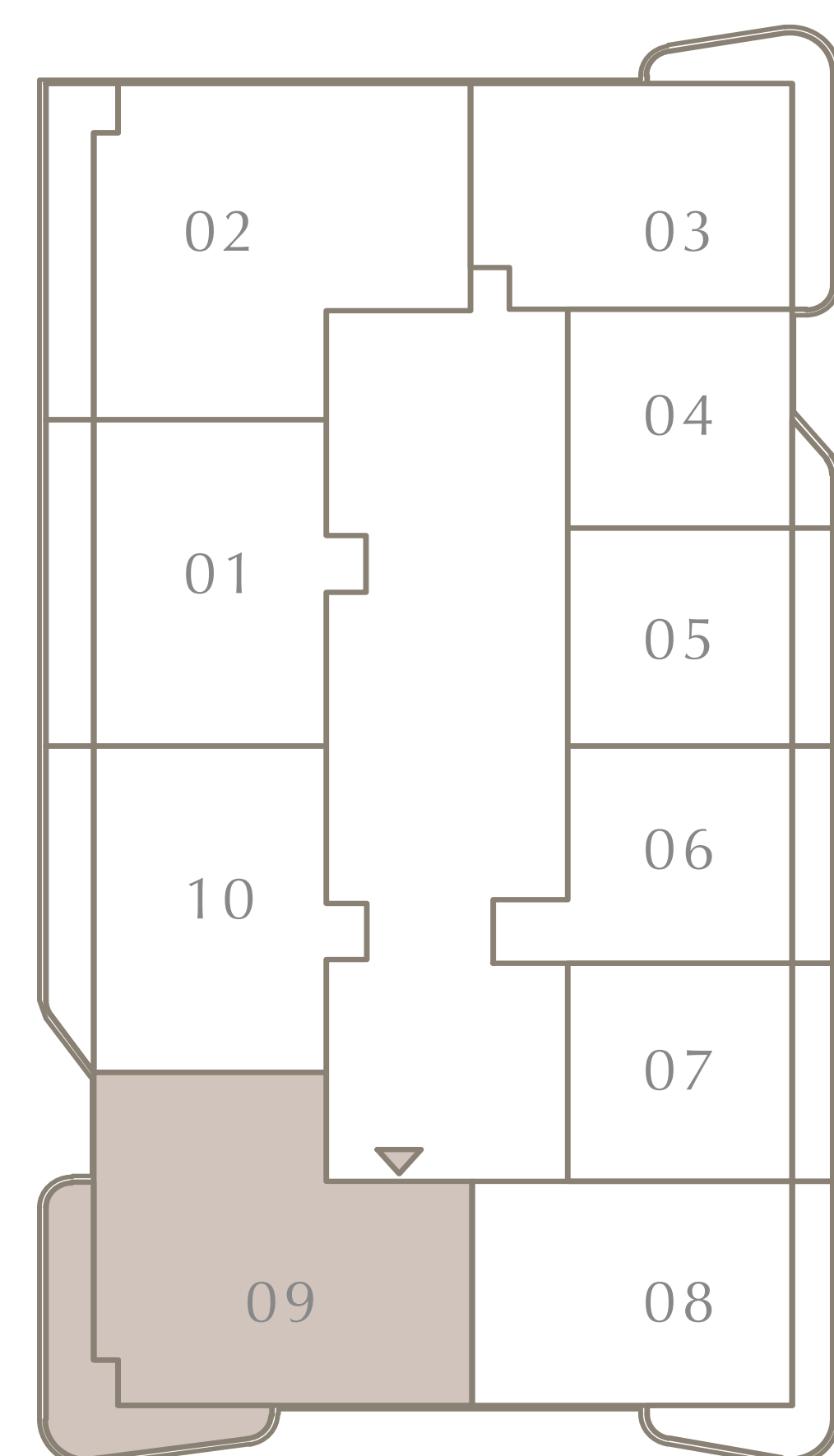

KEY SECTION

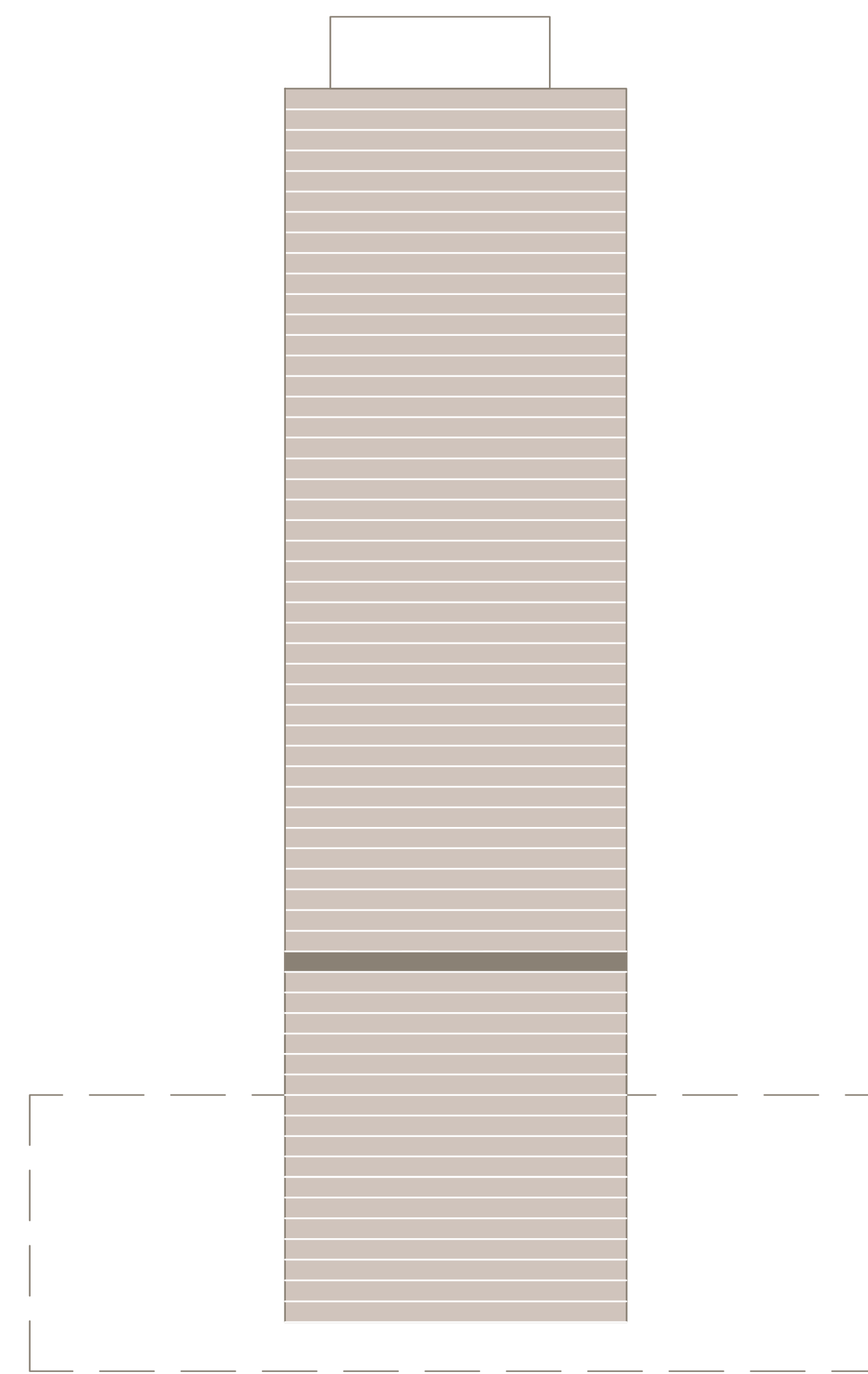

Disclaimer : All dimensions are in imperial and metric, and measured from finish to finish excluding construction tolerances. 2. All materials, dimensions, and drawings are approximate only. 3. Information is subject to change without notice, at developer's absolute discretion. 4. Actual area may vary from the stated area. 5. Drawings not to scale. 6. All images used are for illustrative purposes only and do not represent the actual size, features, specifications, fittings, and furnishings. 7. The developer reserves the right to make revisions / alterations, at its absolute discretion, without any liability whatsoever.



# ADDRESS RESIDENCES THE BAY

## 2 BEDROOM TYPE A 1

LEVEL 18 | UNIT 10

SUITE AREA	1156.26 SQ.FT.	107.42 SQ.M.
BALCONY AREA	227.23 SQ.FT.	21.11 SQ.M.
TOTAL AREA	1383.49 SQ.FT.	128.53 SQ.M.

KEY PLAN LEVEL

18

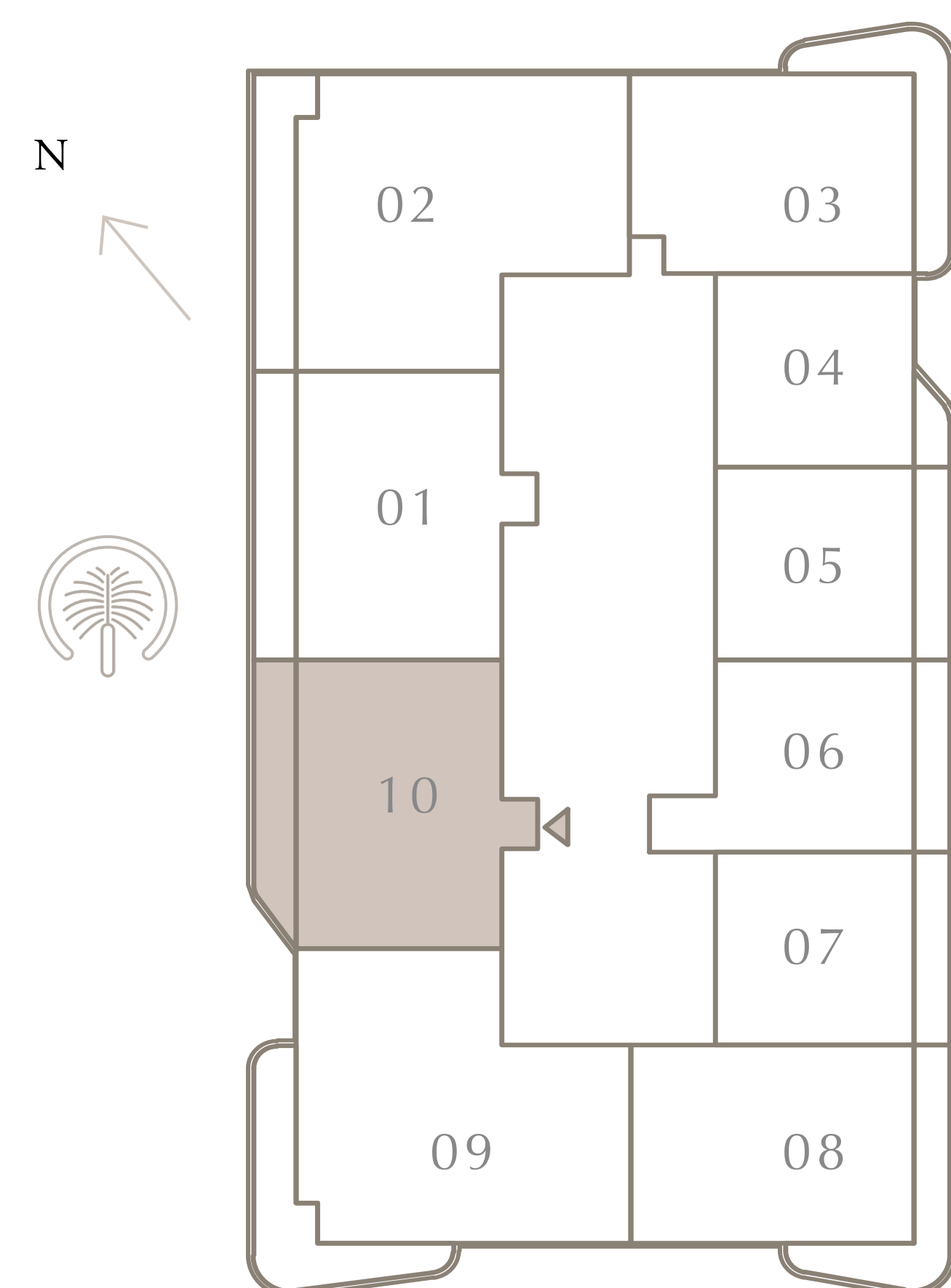

KEY SECTION

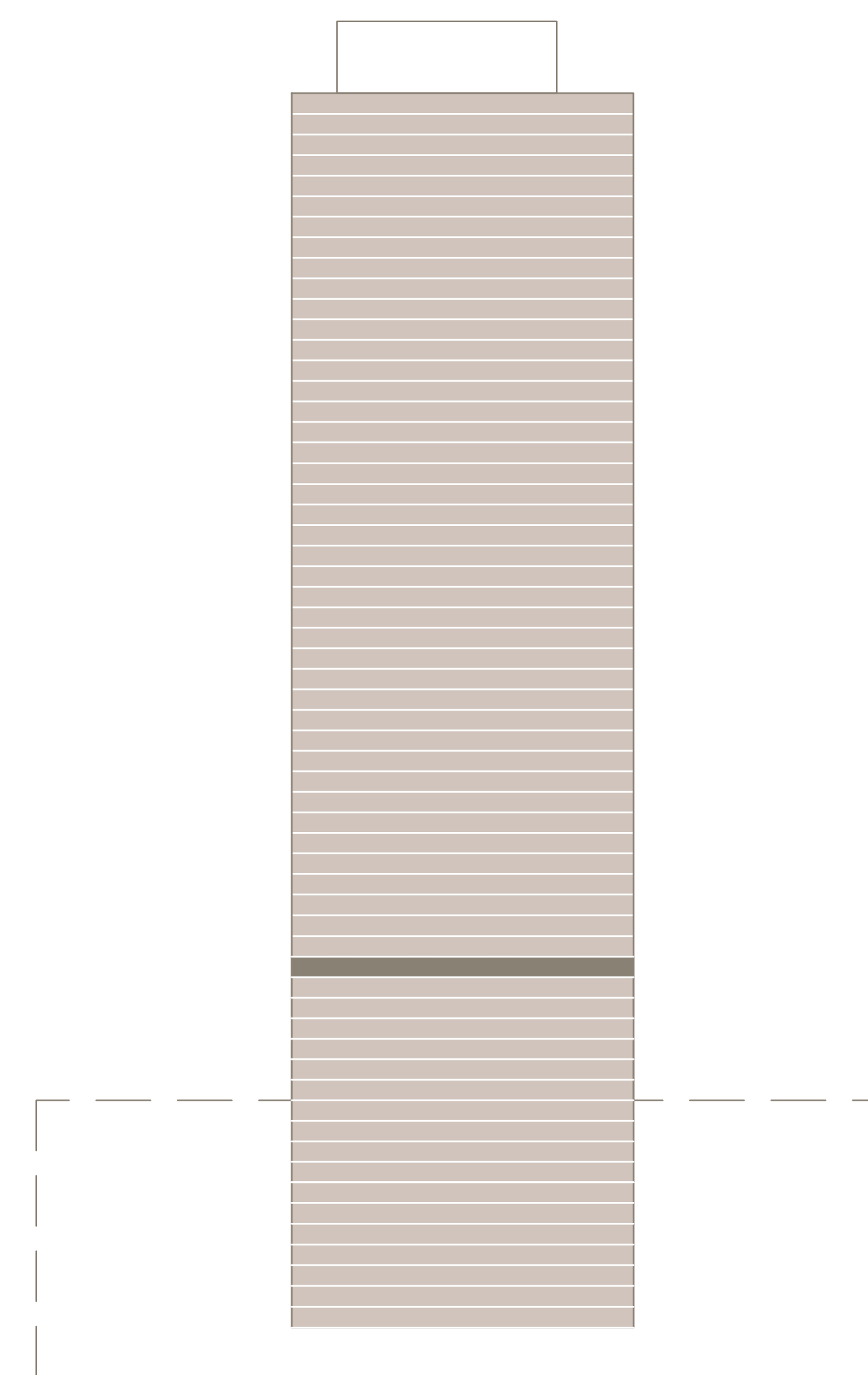

Disclaimer : All dimensions are in imperial and metric, and measured from finish to finish excluding construction tolerances. 2. All materials, dimensions, and drawings are approximate only. 3. Information is subject to change without notice, at developer's absolute discretion. 4. Actual area may vary from the stated area. 5. Drawings not to scale. 6. All images used are for illustrative purposes only and do not represent the actual size, features, specifications, fittings, and furnishings. 7. The developer reserves the right to make revisions / alterations, at its absolute discretion, without any liability whatsoever.



# ADDRESS RESIDENCES THE BAY

## TOWNHOUSE

LEVELS 01-02 | UNIT 106

SUITE AREA	2262.14 SQ.FT.	210.16 SQ.M.
BALCONY AREA	412.90 SQ.FT.	38.36 SQ.M.
TOTAL AREA	2675.04 SQ.FT.	248.52 SQ.M.

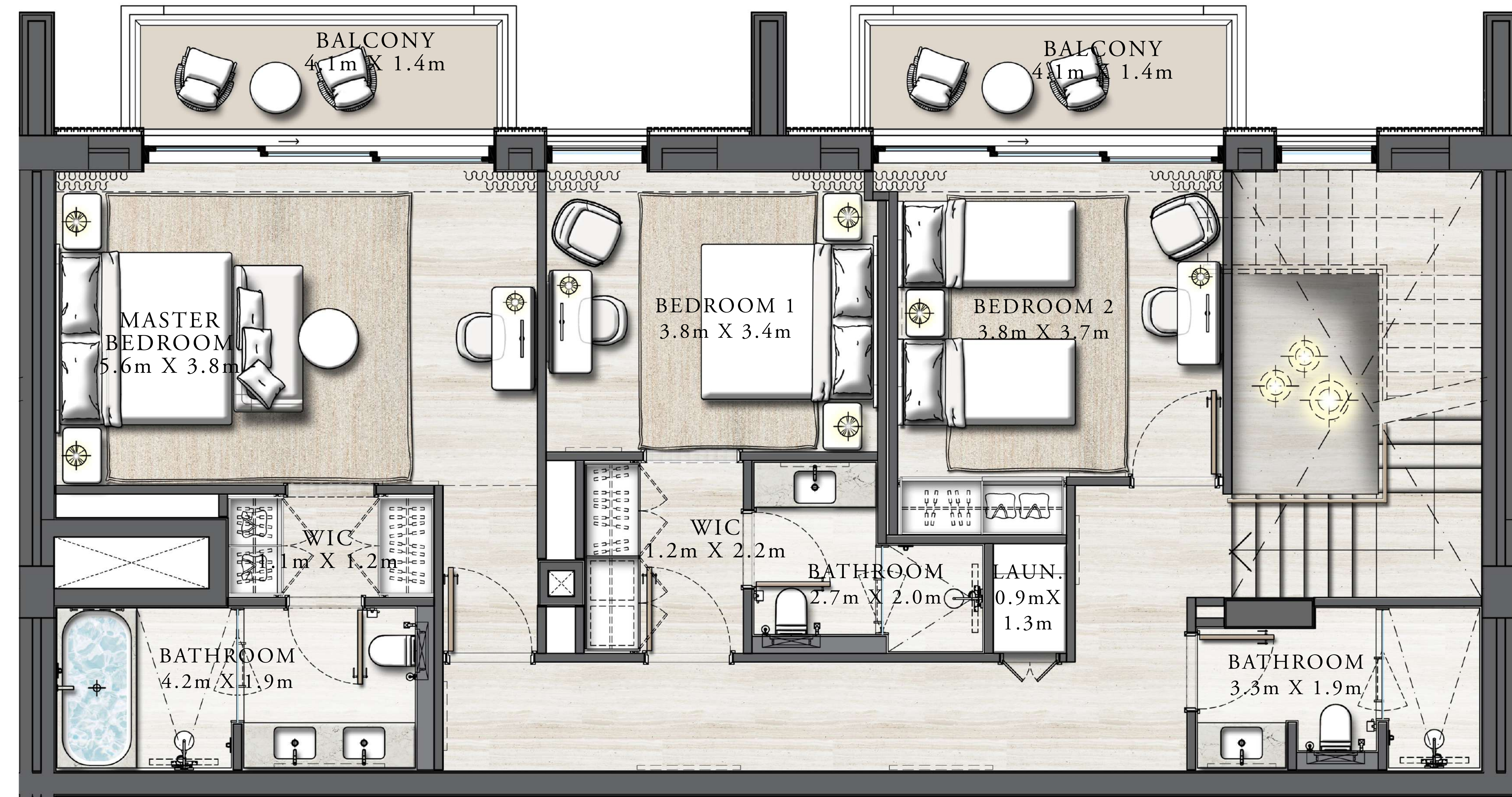

UPPER LEVEL

KEY PLAN LEVEL

01-02

KEY SECTION

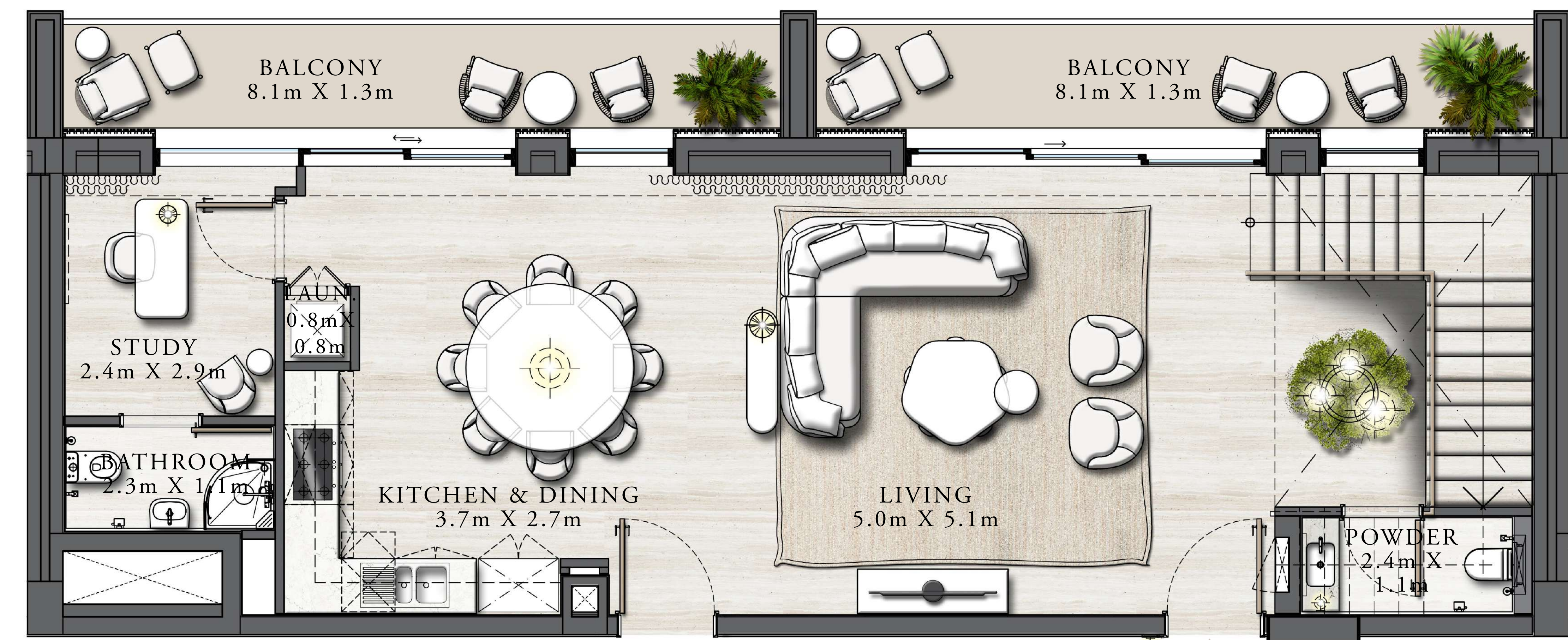
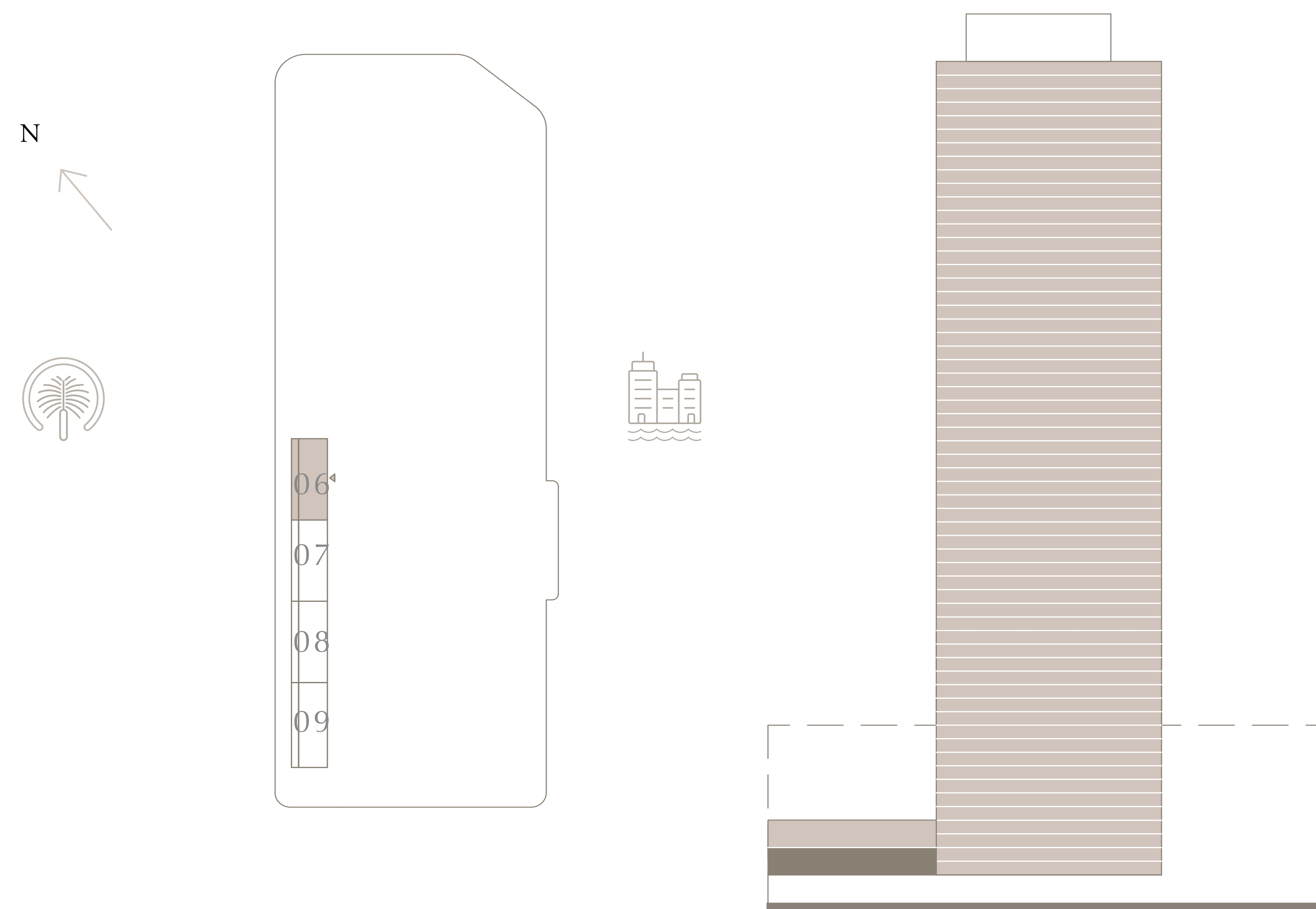

LOWER LEVEL

Disclaimer : All dimensions are in imperial and metric, and measured from finish to finish excluding construction tolerances. 2. All materials, dimensions, and drawings are approximate only. 3. Information is subject to change without notice, at developer's absolute discretion. 4. Actual area may vary from the stated area. 5. Drawings not to scale. 6. All images used are for illustrative purposes only and do not represent the actual size, features, specifications, fittings, and furnishings. 7. The developer reserves the right to make revisions / alterations, at its absolute discretion, without any liability whatsoever.





# ADDRESS RESIDENCES THE BAY

## TOWNHOUSE

LEVELS 01-02

UNITS 107&108

SUITE AREA	2269.03 SQ.FT.	210.80 SQ.M.
BALCONY AREA	413.76 SQ.FT.	38.44 SQ.M.
TOTAL AREA	2682.79 SQ.FT.	249.24 SQ.M.

KEY PLAN LEVEL

01-02

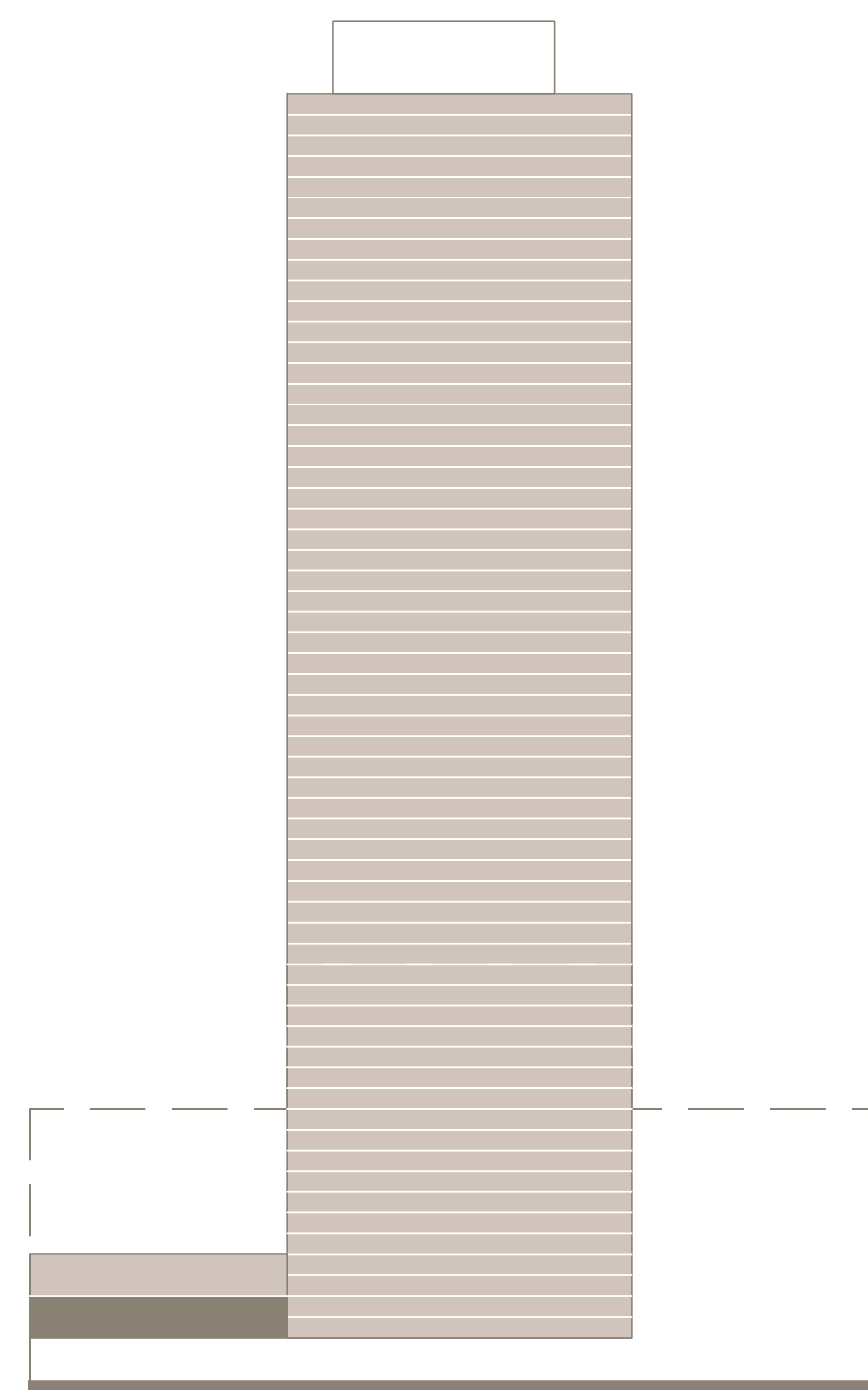
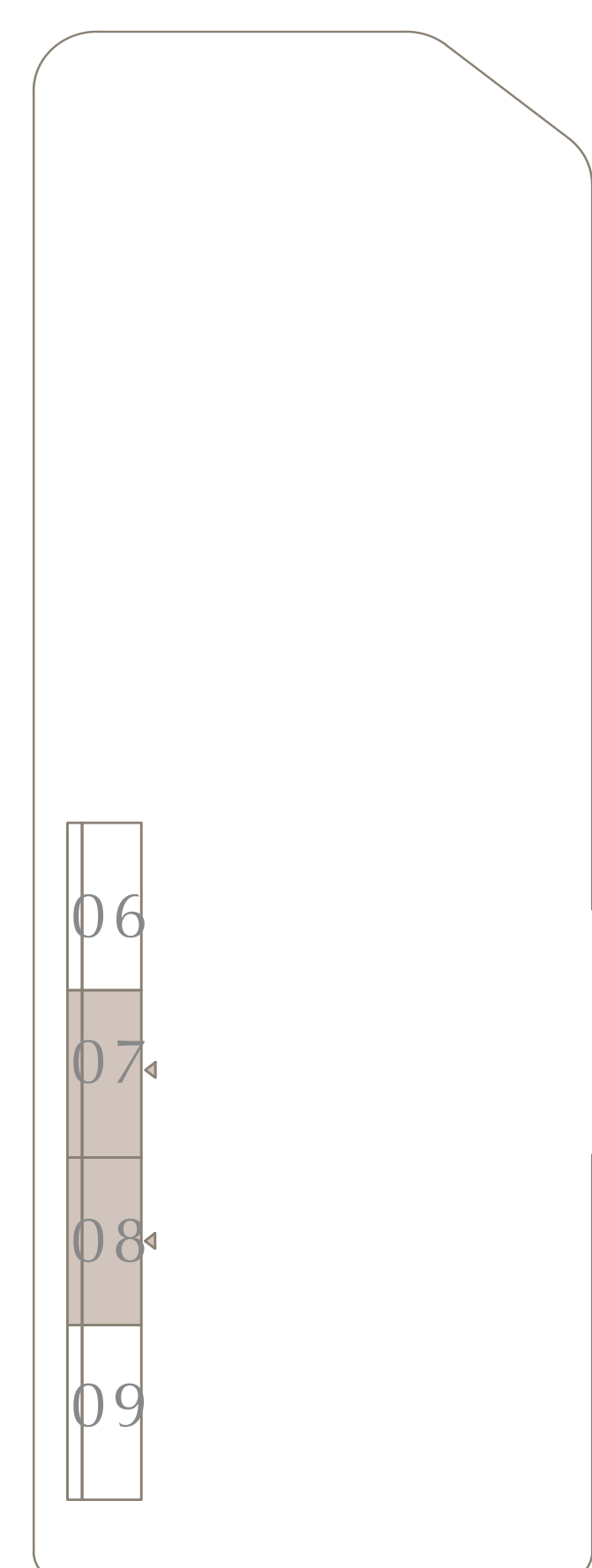
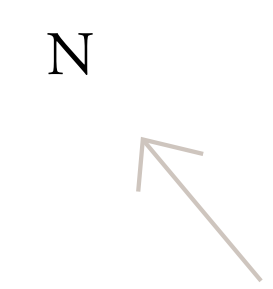

KEY SECTION

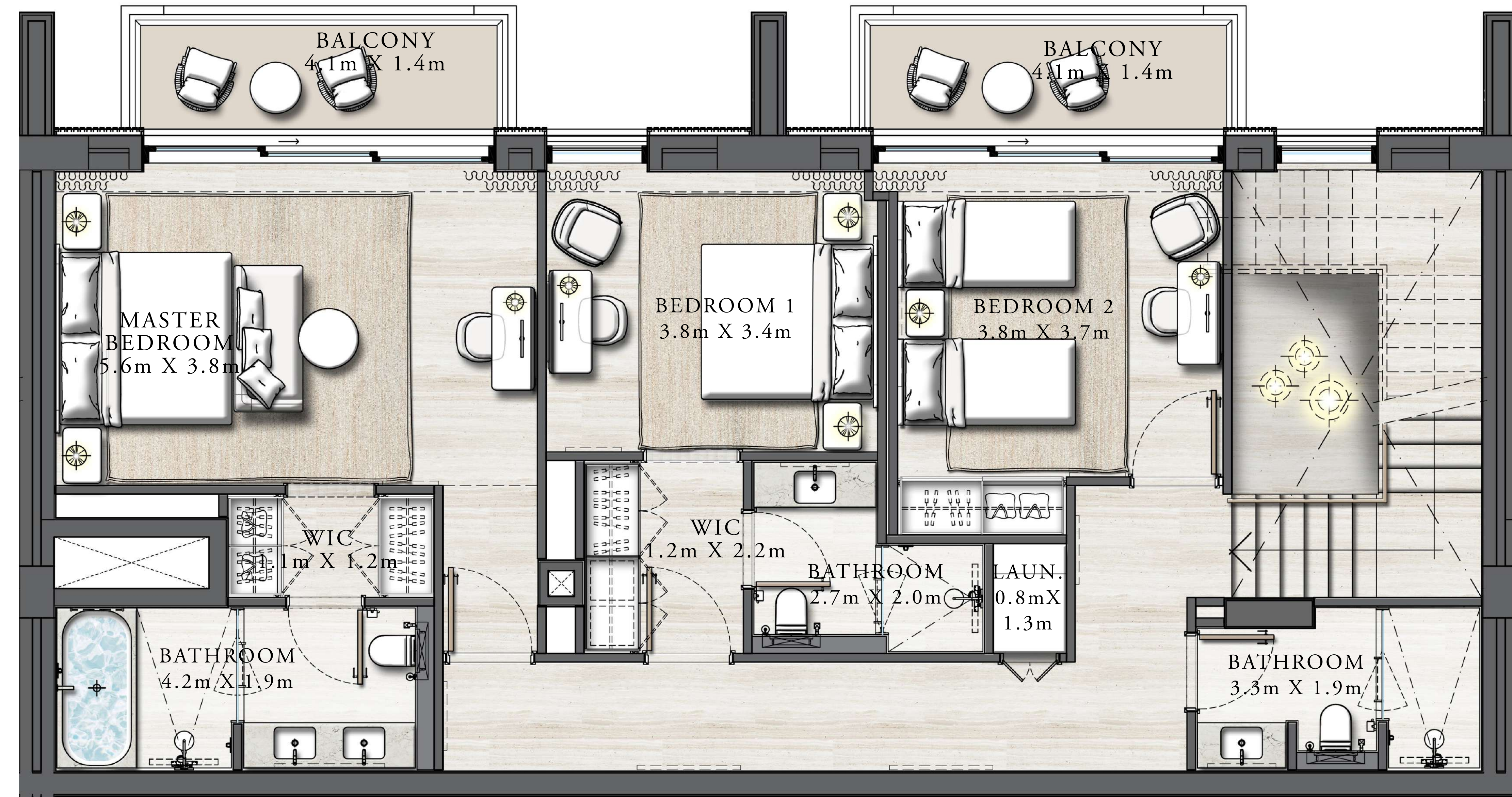

UPPER LEVEL

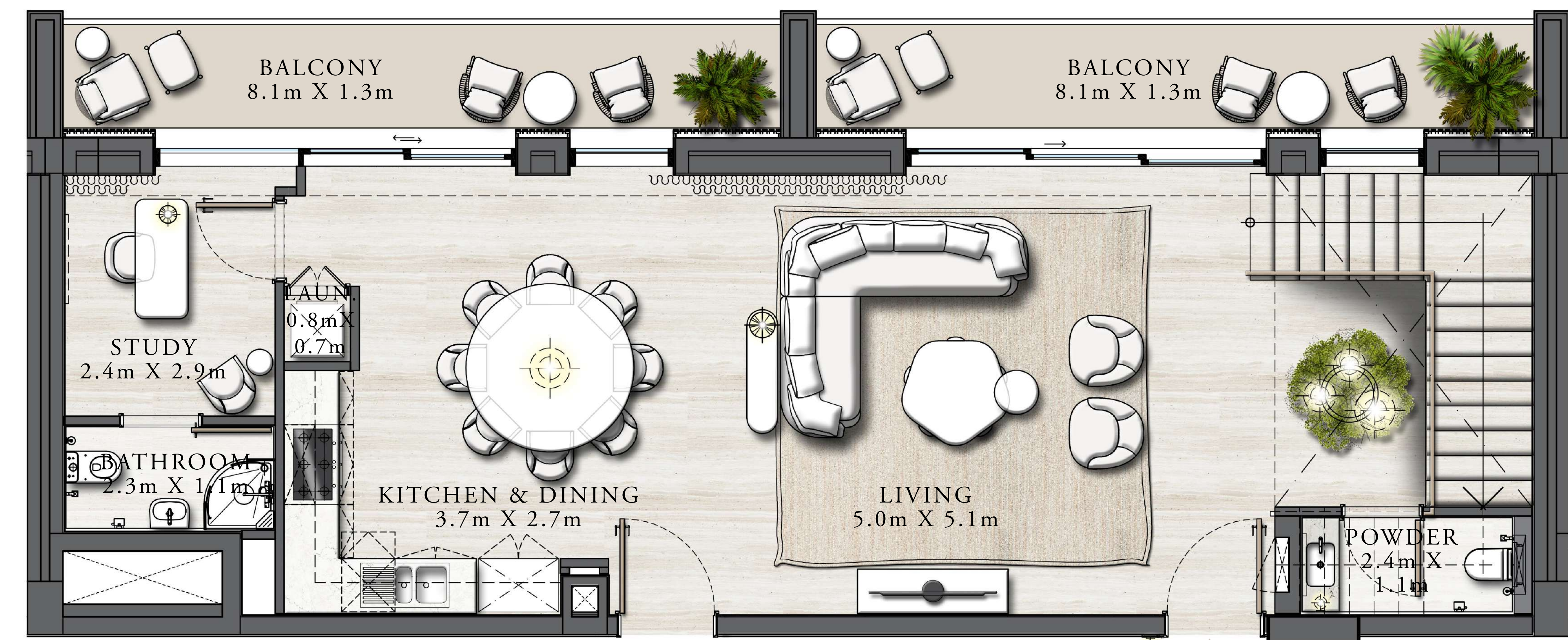

LOWER LEVEL

Disclaimer : All dimensions are in imperial and metric, and measured from finish to finish excluding construction tolerances. 2. All materials, dimensions, and drawings are approximate only. 3. Information is subject to change without notice, at developer's absolute discretion. 4. Actual area may vary from the stated area. 5. Drawings not to scale. 6. All images used are for illustrative purposes only and do not represent the actual size, features, specifications, fittings, and furnishings. 7. The developer reserves the right to make revisions / alterations, at its absolute discretion, without any liability whatsoever.



# ADDRESS RESIDENCES THE BAY

## TOWNHOUSE

LEVELS 01-02 | UNIT 109

SUITE AREA	2293.58 SQ.FT.	213.08 SQ.M.
BALCONY AREA	421.40 SQ.FT.	39.15 SQ.M.
TOTAL AREA	2714.98 SQ.FT.	252.23 SQ.M.

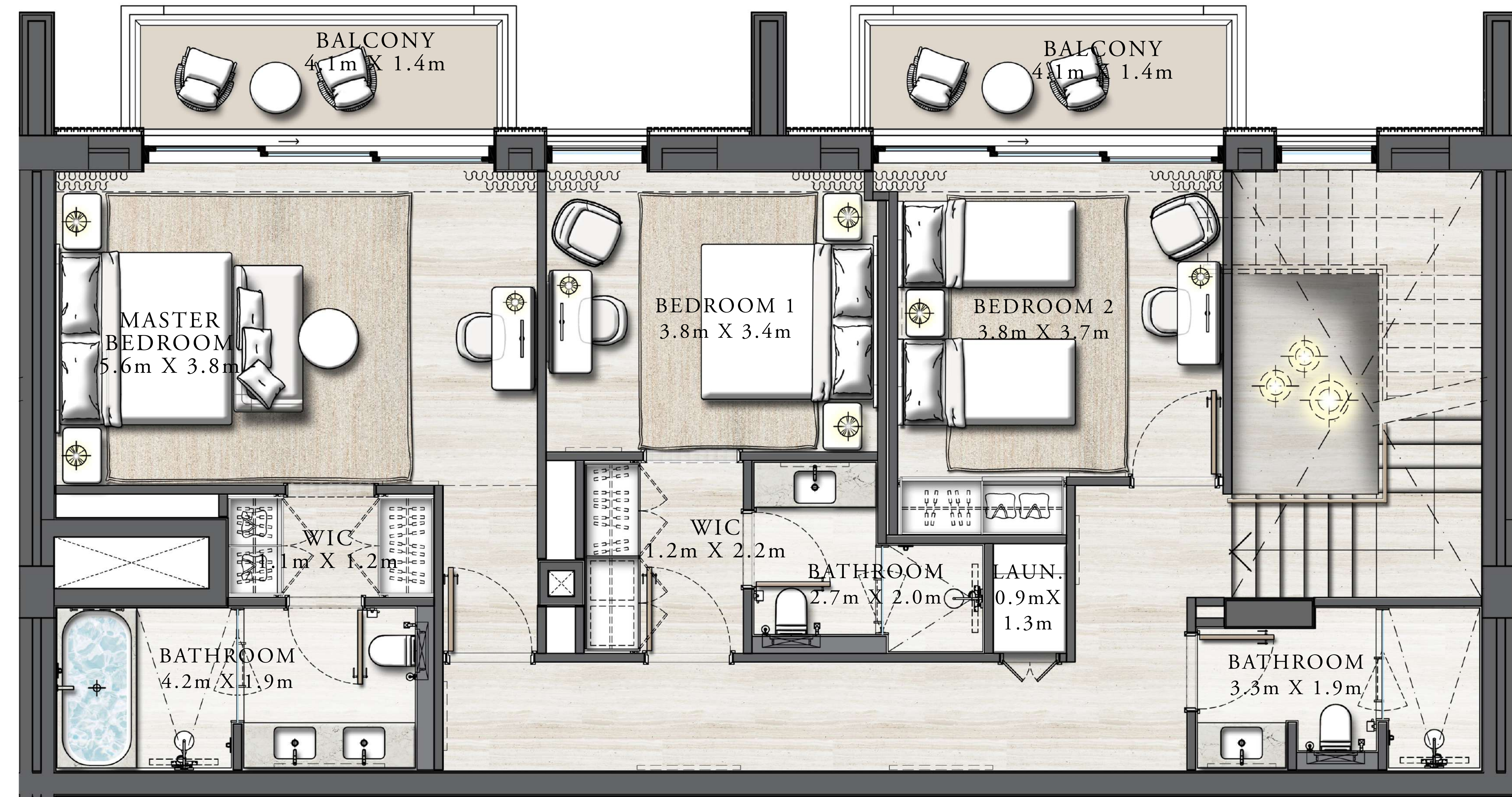

UPPER LEVEL

KEY PLAN LEVEL

01-02

KEY SECTION

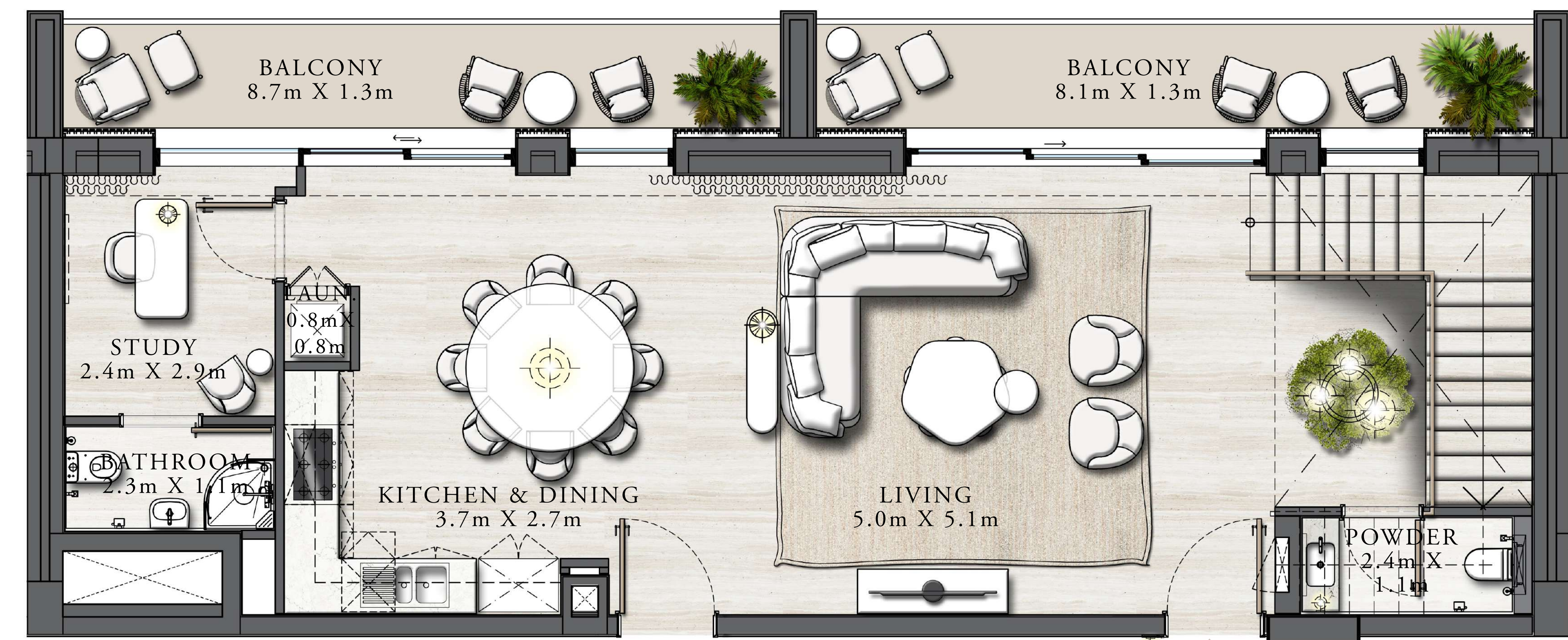
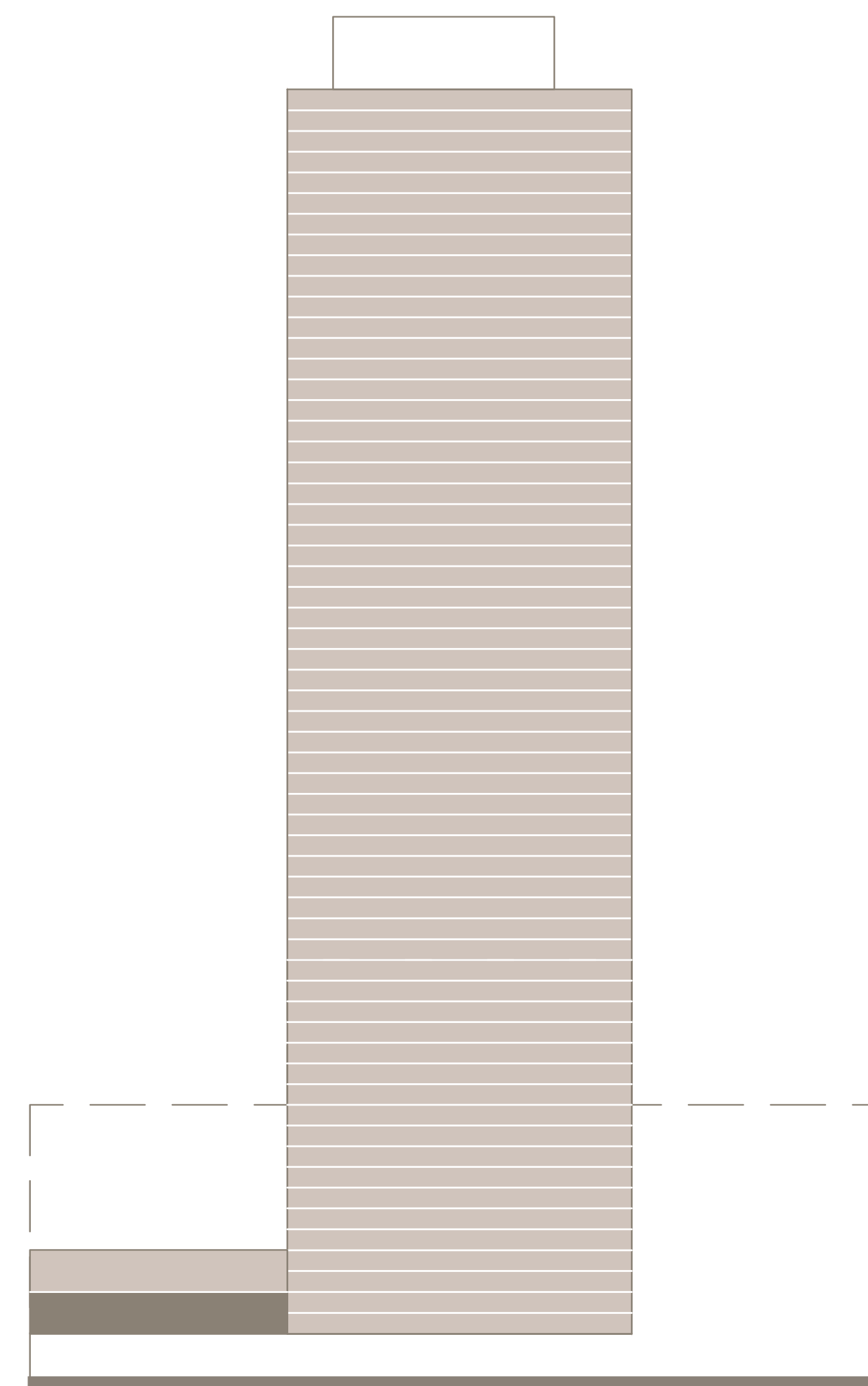
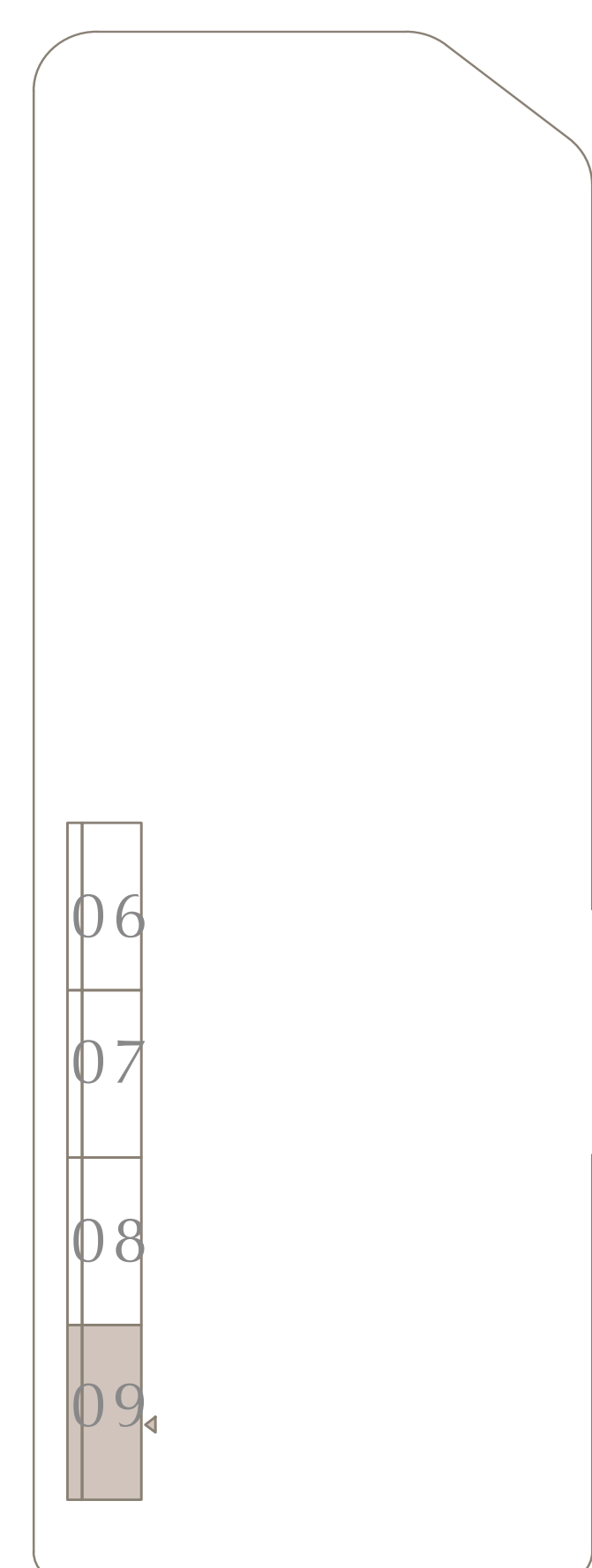
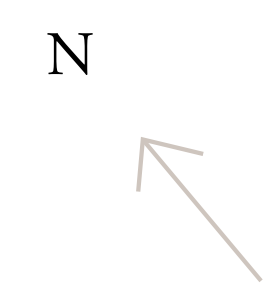

LOWER LEVEL

Disclaimer : All dimensions are in imperial and metric, and measured from finish to finish excluding construction tolerances. 2. All materials, dimensions, and drawings are approximate only. 3. Information is subject to change without notice, at developer's absolute discretion. 4. Actual area may vary from the stated area. 5. Drawings not to scale. 6. All images used are for illustrative purposes only and do not represent the actual size, features, specifications, fittings, and furnishings. 7. The developer reserves the right to make revisions / alterations, at its absolute discretion, without any liability whatsoever.



# ADDRESS RESIDENCES THE BAY

## TOWNHOUSE

LEVELS 03-04 | UNIT 306

SUITE AREA	2262.14 SQ.FT.	210.16 SQ.M.
BALCONY AREA	412.90 SQ.FT.	38.36 SQ.M.
TOTAL AREA	2675.04 SQ.FT.	248.52 SQ.M.

KEY PLAN LEVEL

03-04

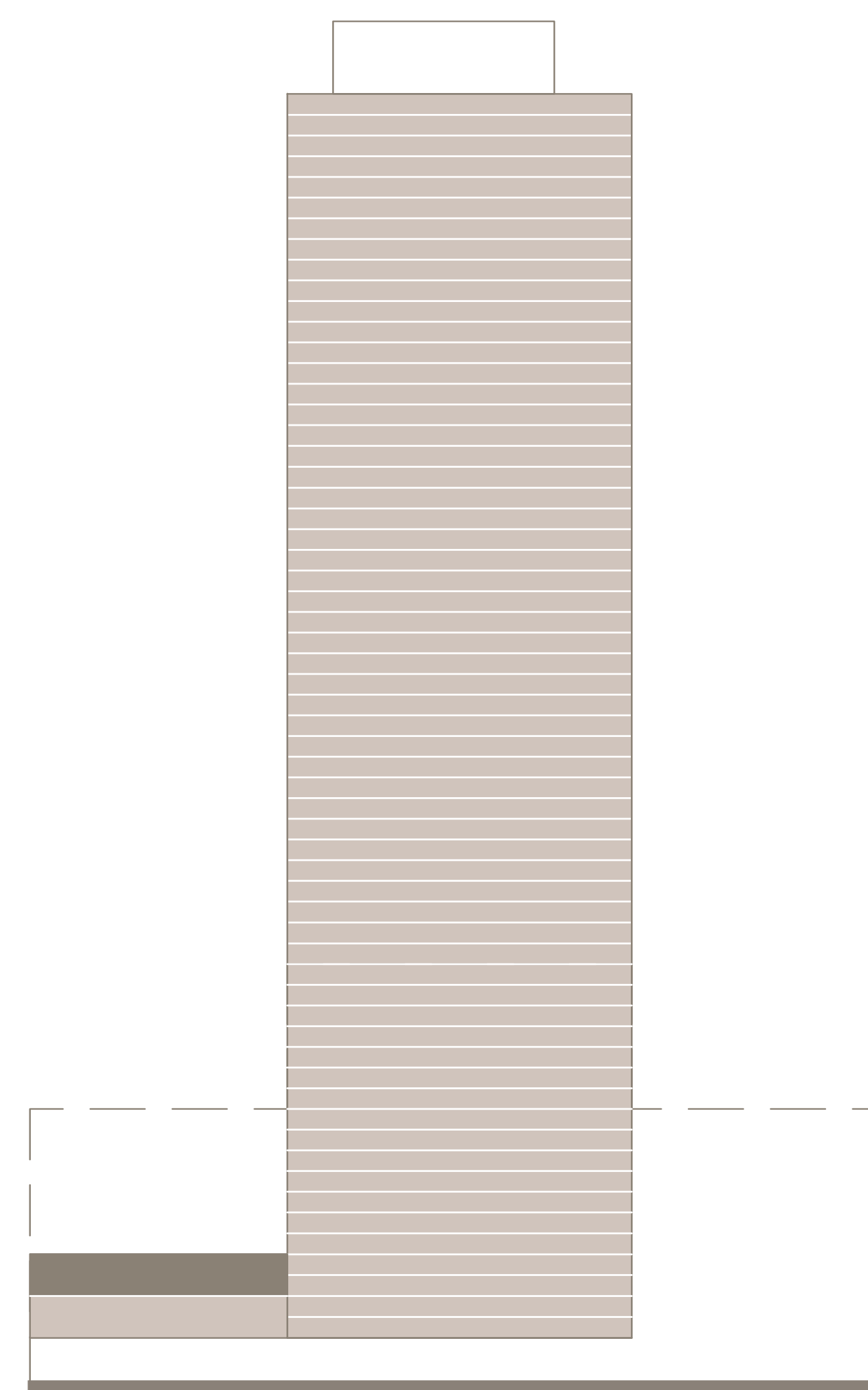
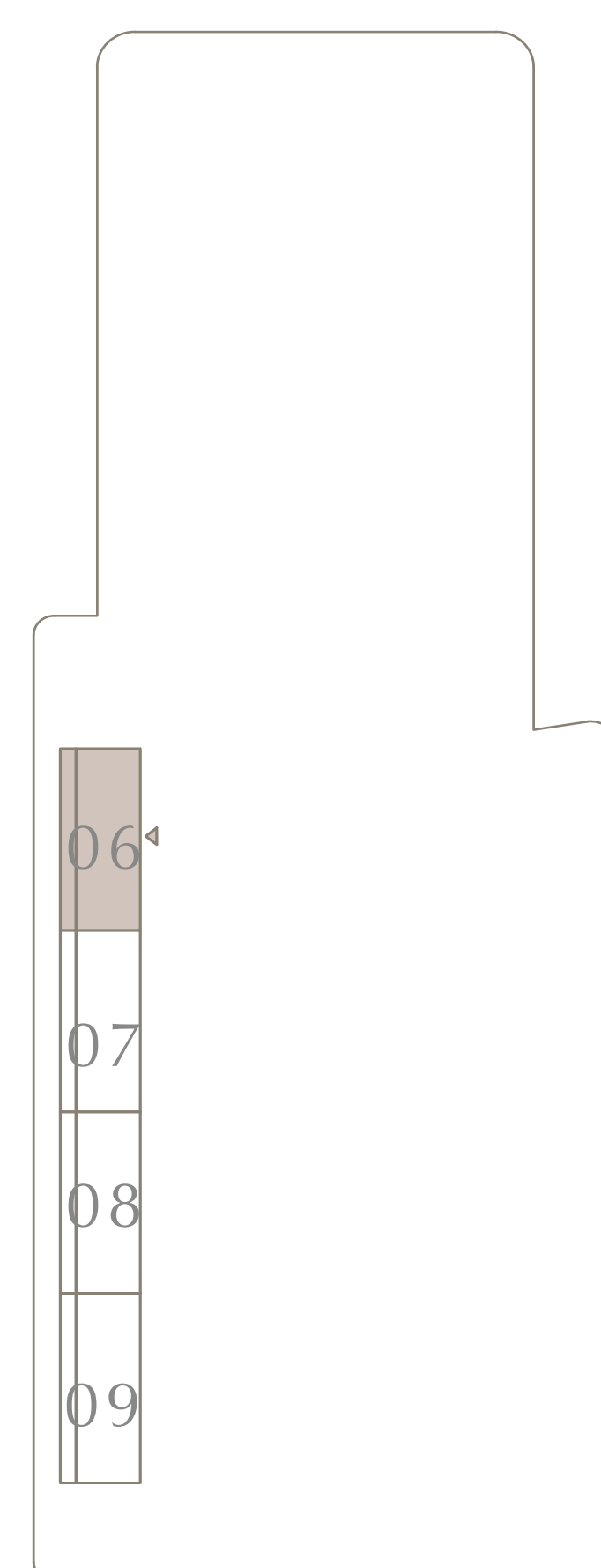
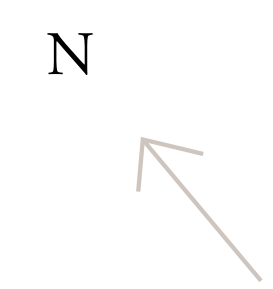

KEY SECTION

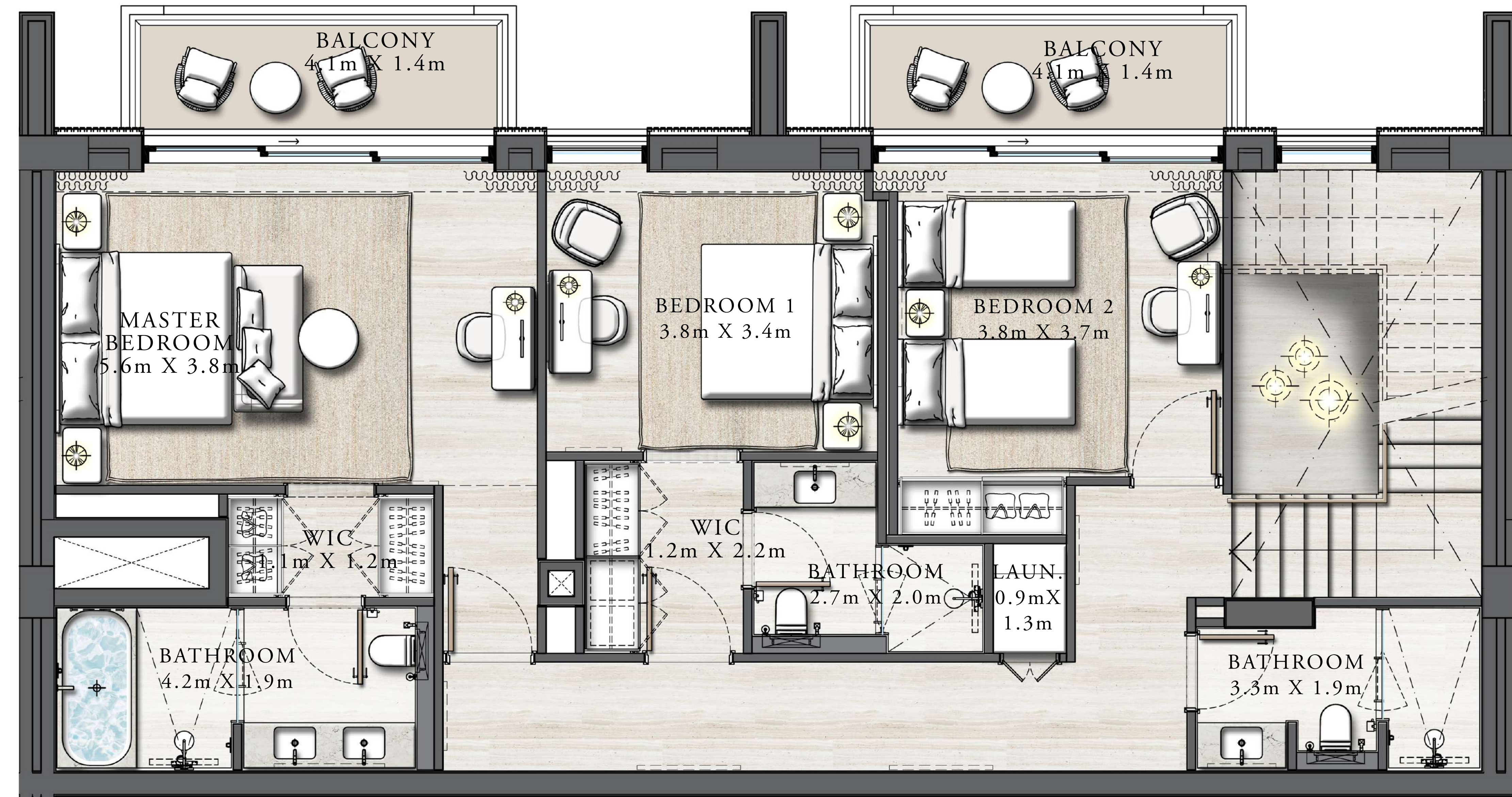

UPPER LEVEL

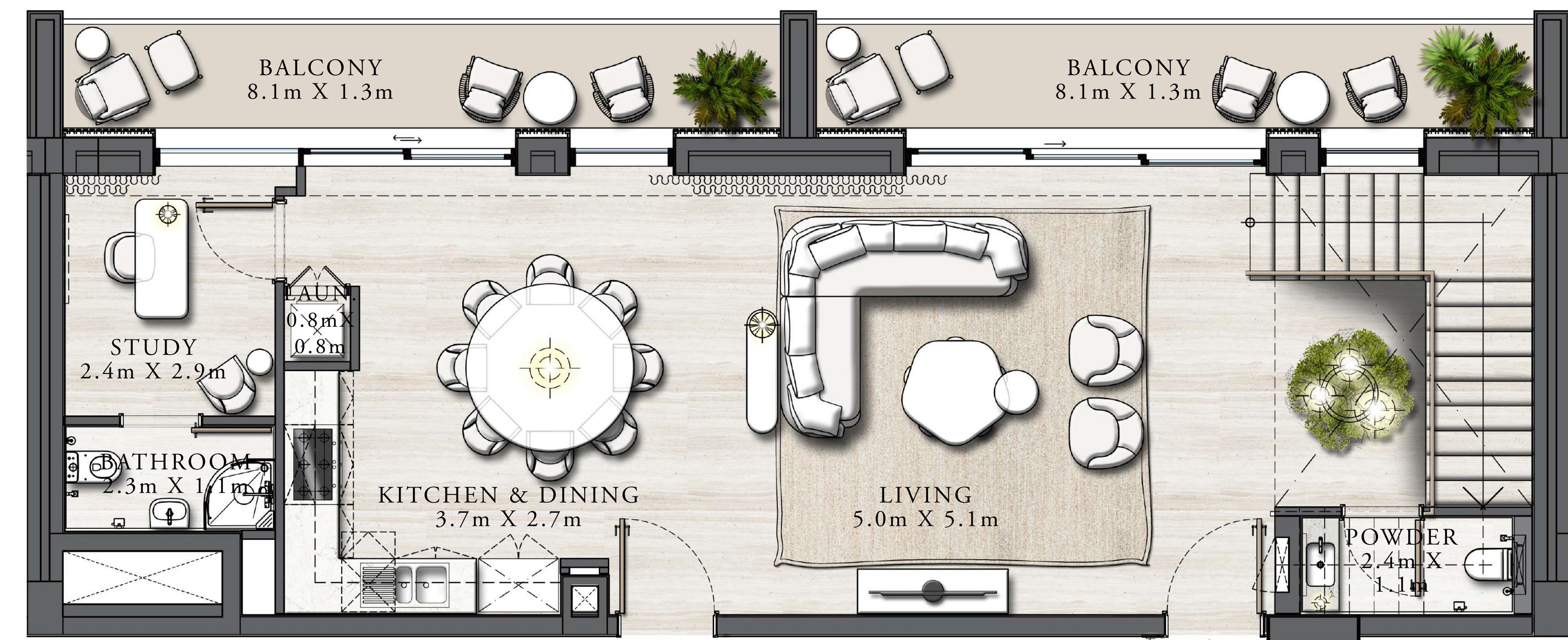

LOWER LEVEL

Disclaimer : All dimensions are in imperial and metric, and measured from finish to finish excluding construction tolerances. 2. All materials, dimensions, and drawings are approximate only. 3. Information is subject to change without notice, at developer's absolute discretion. 4. Actual area may vary from the stated area. 5. Drawings not to scale. 6. All images used are for illustrative purposes only and do not represent the actual size, features, specifications, fittings, and furnishings. 7. The developer reserves the right to make revisions / alterations, at its absolute discretion, without any liability whatsoever.



# ADDRESS RESIDENCES THE BAY

## TOWNHOUSE

LEVELS 03-04 | UNITS 307 & 308

SUITE AREA	2269.03 SQ.FT.	210.80 SQ.M.
BALCONY AREA	413.76 SQ.FT.	38.44 SQ.M.
TOTAL AREA	2682.79 SQ.FT.	249.24 SQ.M.



UPPER LEVEL

KEY PLAN LEVEL

03-04

KEY SECTION

N

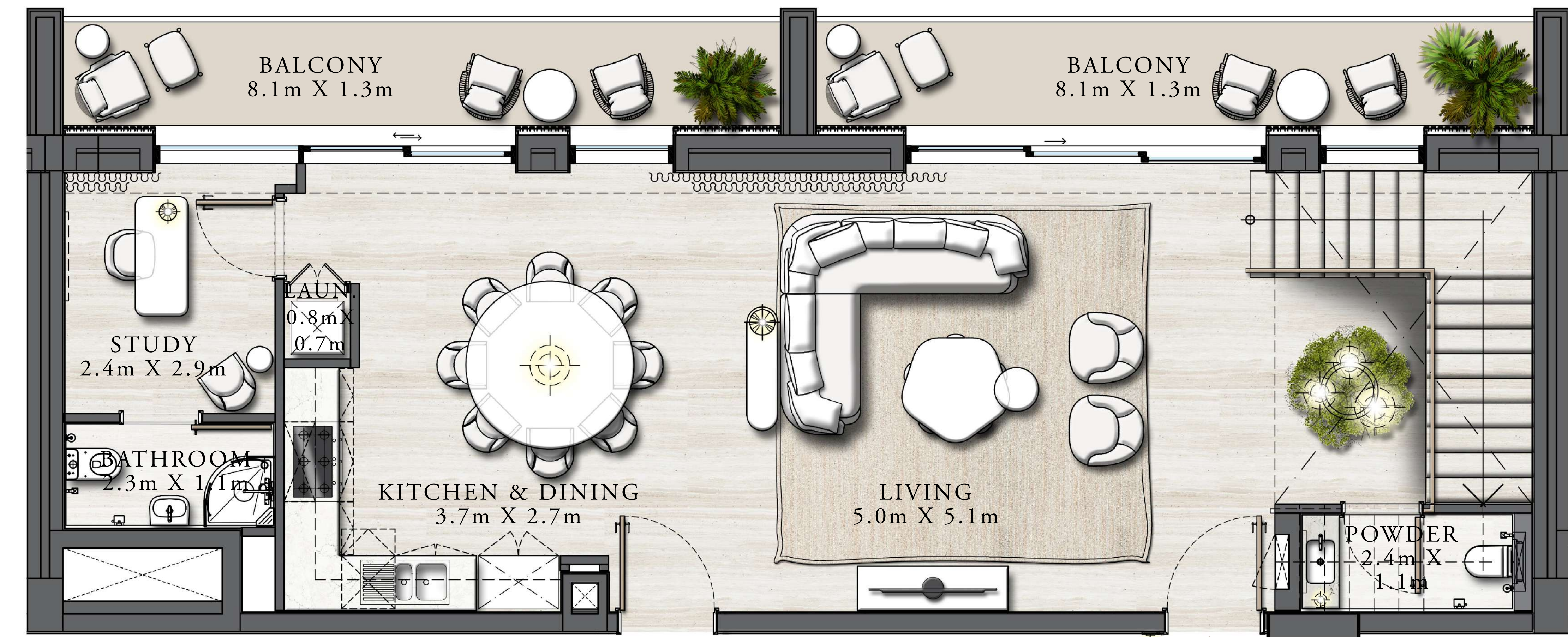
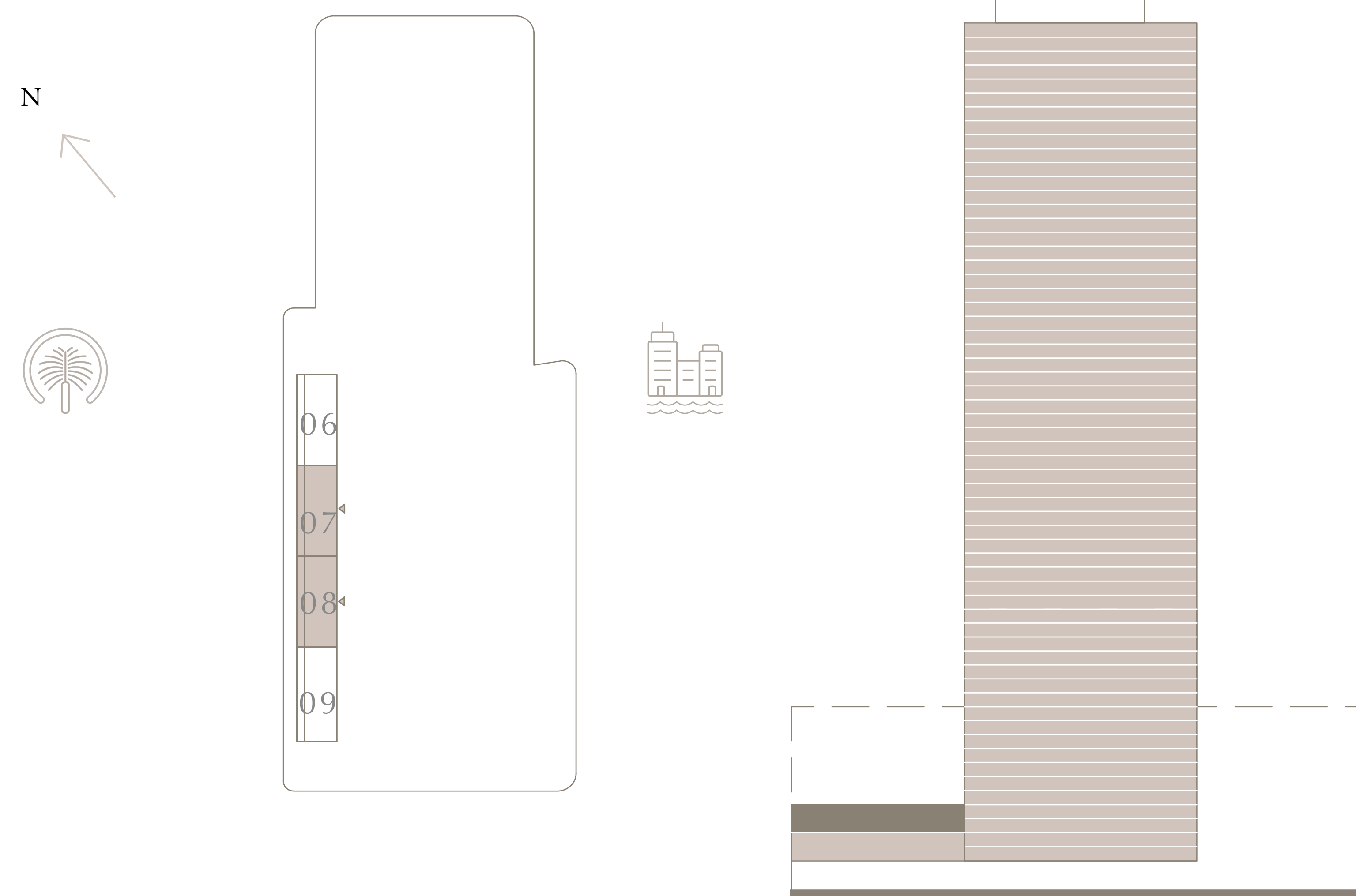

LOWER LEVEL

Disclaimer : All dimensions are in imperial and metric, and measured from finish to finish excluding construction tolerances. 2. All materials, dimensions, and drawings are approximate only. 3. Information is subject to change without notice, at developer's absolute discretion. 4. Actual area may vary from the stated area. 5. Drawings not to scale. 6. All images used are for illustrative purposes only and do not represent the actual size, features, specifications, fittings, and furnishings. 7. The developer reserves the right to make revisions / alterations, at its absolute discretion, without any liability whatsoever.



# ADDRESS RESIDENCES THE BAY

## TOWNHOUSE

LEVELS 03-04 | UNIT 309

SUITE AREA	2293.58 SQ.FT.	213.08 SQ.M.
BALCONY AREA	421.40 SQ.FT.	39.15 SQ.M.
TOTAL AREA	2714.98 SQ.FT.	252.23 SQ.M.

KEY PLAN LEVEL

03-04

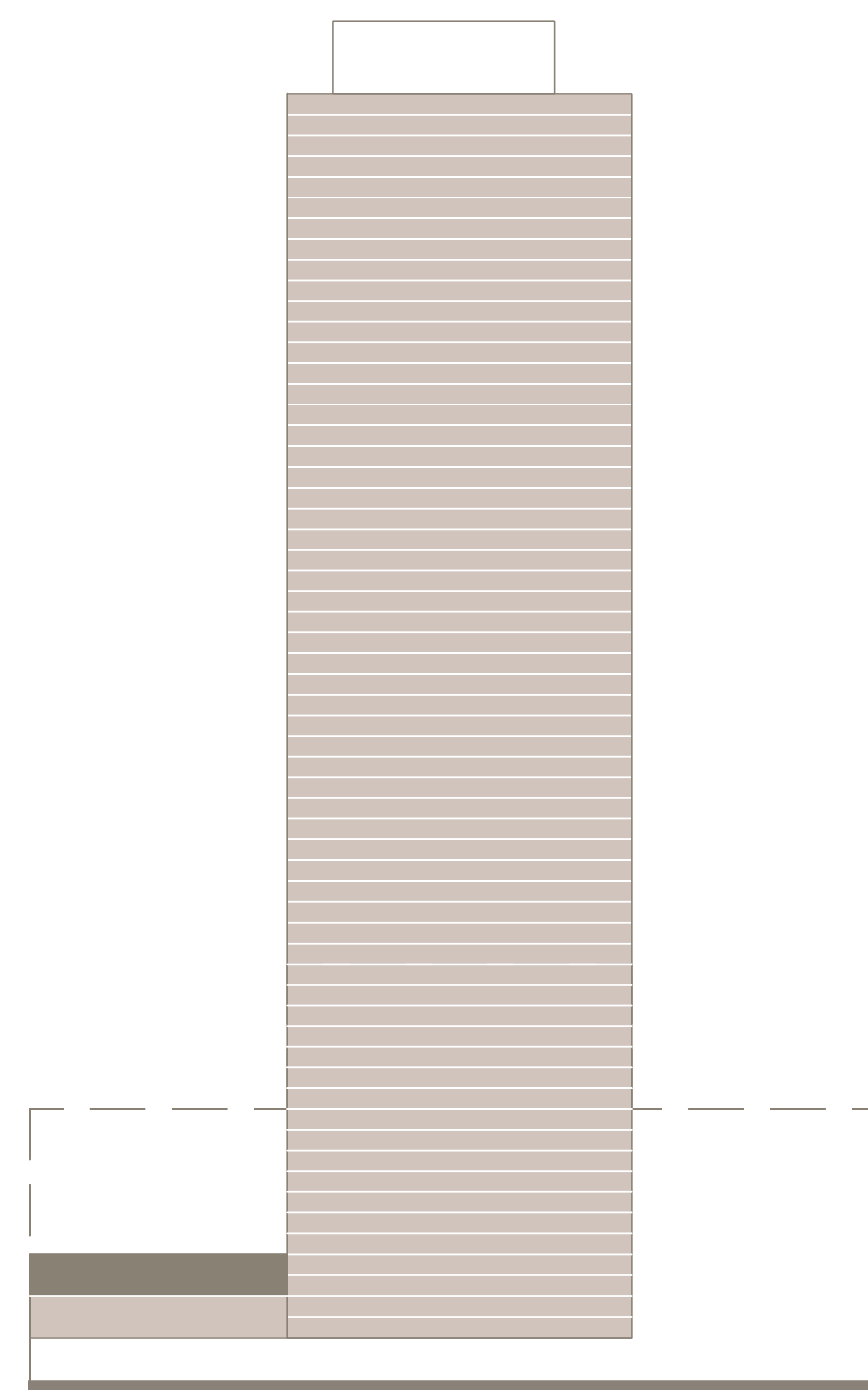
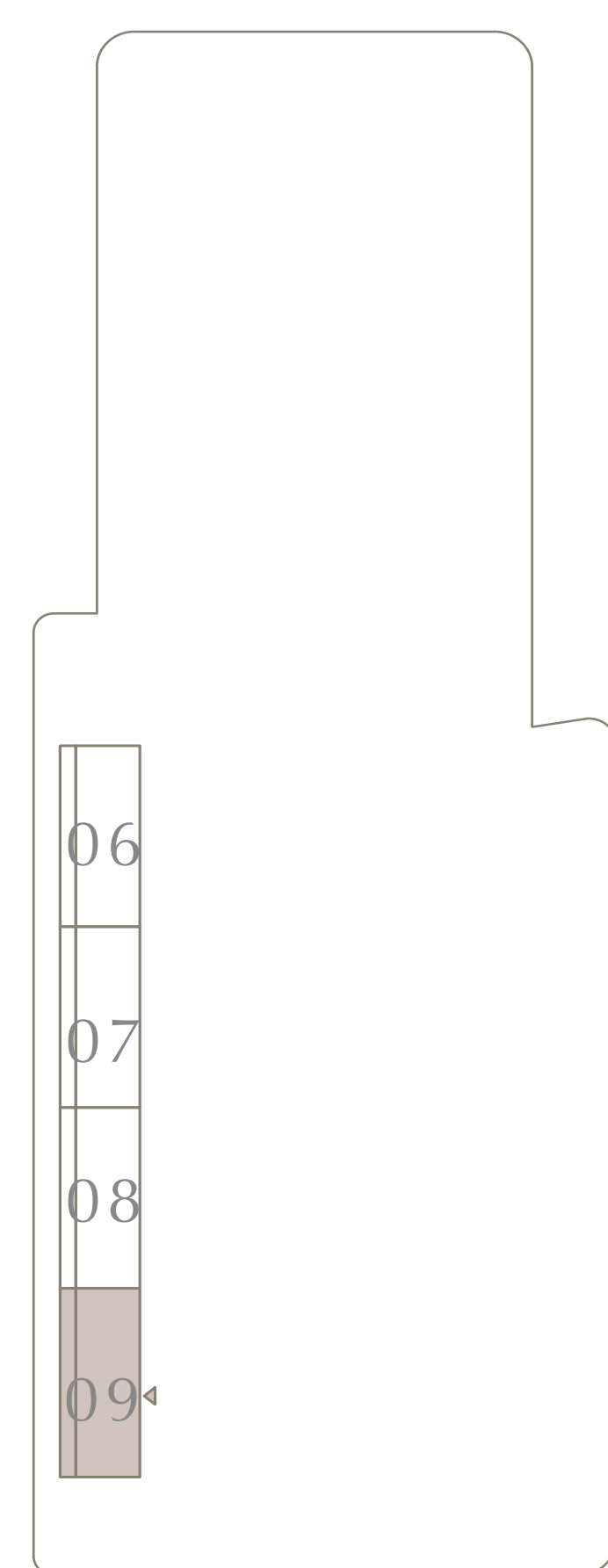
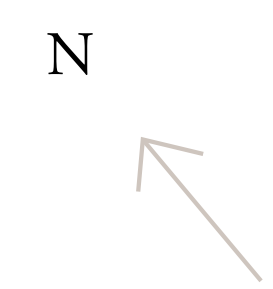

KEY SECTION

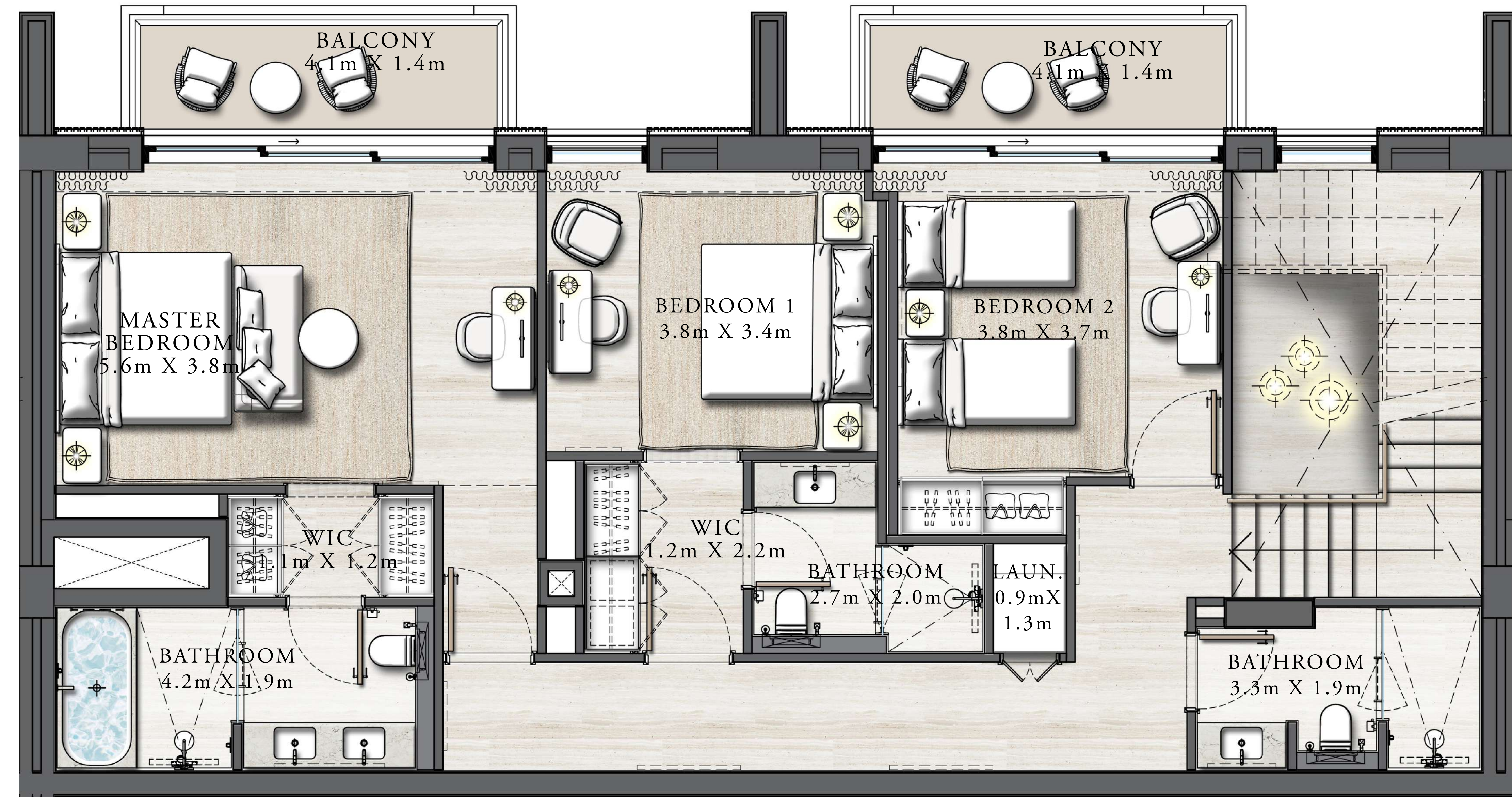

UPPER LEVEL

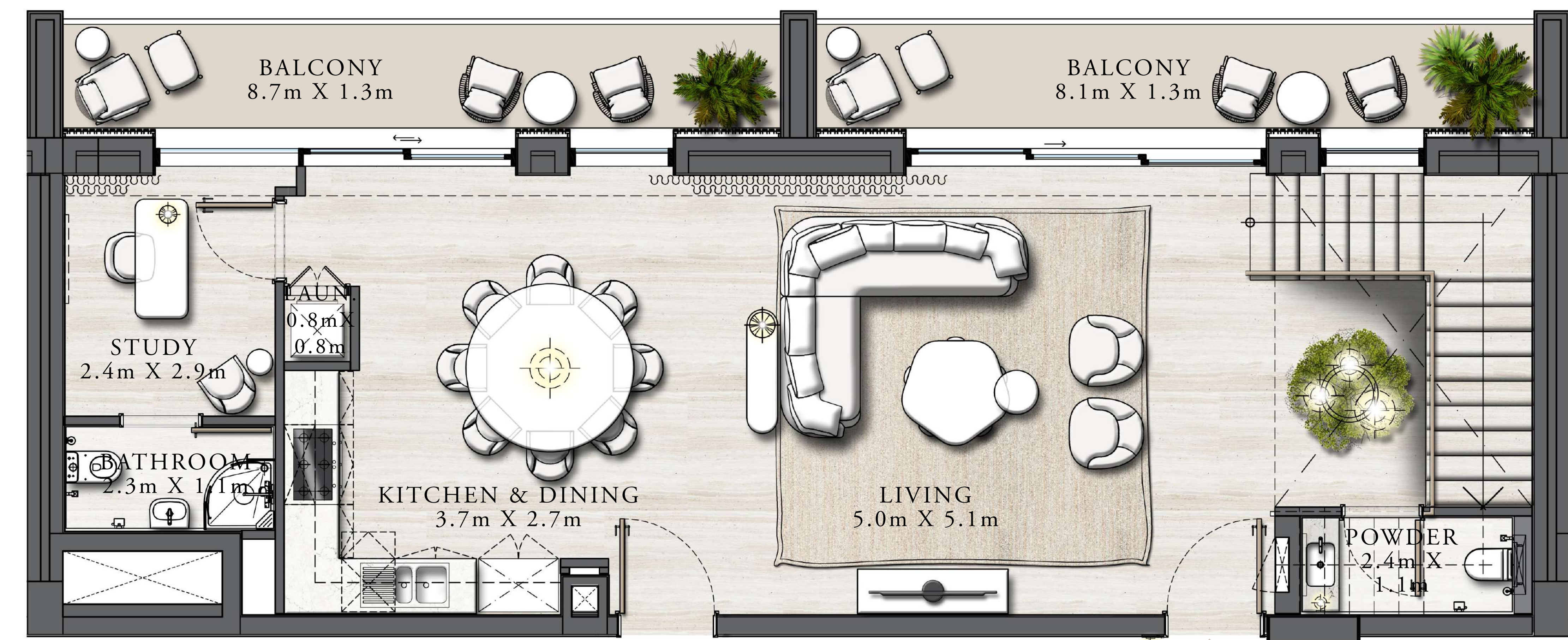

LOWER LEVEL

Disclaimer : All dimensions are in imperial and metric, and measured from finish to finish excluding construction tolerances. 2. All materials, dimensions, and drawings are approximate only. 3. Information is subject to change without notice, at developer's absolute discretion. 4. Actual area may vary from the stated area. 5. Drawings not to scale. 6. All images used are for illustrative purposes only and do not represent the actual size, features, specifications, fittings, and furnishings. 7. The developer reserves the right to make revisions / alterations, at its absolute discretion, without any liability whatsoever.